



Arctic Development
Library

***The Energy Brief - Comments On Alternative
Energy Sources***

Type of Study: Analysis/review

Mining/oil/energy, Energy General

Date of Report: 1982

Author: Canada - Environment Canada

Catalogue Number: 6-5-32

6-5-32

THE ENERGY BRIEF - COMMENTS ON
ALTERNATIVE ENERGY SOURCES

Sector: Mining/ON/Energy

6-5-32

Analysis/Review

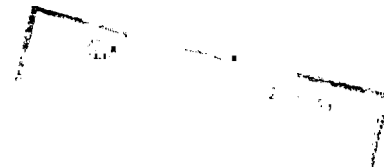

THE ENERGY BRIEF

COMMENTS ON ALTERNATIVE ENERGY SOURCES

**Based on a submission to the Special (Parliamentary)
Committee on Alternative Energy and Oil Substitution**

Corporate Planning Group, Department of the Environment, Ottawa, Ontario

C
E
E ne
1982

Canada

June, 1982

THE ENERGY BRIEF

COMMENTS ON ALTERNATIVE ENERGY SOURCES

**Based on a Submission to the
Special (Parliamentary) Committee on
Alternative Energy and Oil Substitution**

Corporate Planning Group
Department of the Environment
Ottawa, Ontario

June, 1982

Table of Contents

Foreword	v
Deputy Minister's Remarks	
Executive Summary	xi
1 Introduction	1
2 Energy and the Environment — A Perspective	3
3 Potential of Alternative Energy Resources	5
4 Environmental Implications of Energy Options	13
5 Conservation — An Energy Alternative	17
6 Selecting Energy Options — Factors for Consideration	21
6.1 Energy Conservation as an Option	21
6.2 Renewable Resource Potential	21
6.3 State of Technology	21
6.4 Environmental Implications	21
6.5 Economics	22
6.6 Social Change	22
6.7 Energy Supply Flexibility	23
6.8 Net Energy Analysis	23
6.9 Assessing "Intangible" Factors	23
7 Energy Research and Development	25
8 Developing a Strategy for Canada's Energy Future	27
References	29
Appendix A: Alternative Energy Resources	31
A-0 Introduction	33
A-1 Solar Radiation	34
A-2 Wind	37
A-3 Alternate Hydro	40
A-4 Tidal Power	42
A-5 Wave Energy	44
A-6 Thermal and Salinity Gradients	45
A-7 Biomass	46
A-8 Municipal Solid Wastes	51
A-9 Geothermal Energy	53
A-10 Peat	55
References to Appendix A	59

Appendix B: Alternative Technologies for Energy Conversion	61
B-0 Introduction	63
B-1 Coal Liquefaction and Gasification	66
B-2 Fluidized Bed Combustion	69
B-3 Magnetohydrodynamics (MHD)	71
B-4 Combined Cycle Power Generation	74
B-5 Hybrid Fuel Combustion	76
B-6 Hydrogen Energy	77
B-7 Fuel Cells	78
B-8 Nuclear Fusion	79
References to Appendix B	81
Appendix C: Opportunities for Improved Efficiency in Energy Utilization and for Interfuel Substitution	83
C-0 Introduction	85
C-1 Co-generation	86
C-2 District Heating	89
C-3 Heat Pumps	91
C-4 Alternate Transportation Fuels	92
References to Appendix C	95

Foreword

In the fall of 1980 the Department of the Environment presented a brief to the Parliamentary Special Committee on Alternative Energy and Oil Substitution (Mr. Thomas H. Lefebvre, Chairman). This brief was well received and its contents were reflected in the Committee's final report.

The purpose of the brief was to communicate to the Committee the Department's views on a range of considerations having to do with energy. The compilation of the brief involved the participation of many elements of the Department, and ultimately it amounted to a compendium of information and data that is not ordinarily undertaken. It was therefore decided to revise the brief and to publish it for a wider audience. The objective is to provide to policy and decision makers, both within and outside the Department, a source of reference outlining the main environmental concerns that arise from the production and use of energy,

While the brief is organized mainly according to source of energy, it is hoped that the reader will nevertheless develop an appreciation for the complexity of the entire system and the need to scrutinize our real needs for energy. Given the pervasiveness of energy use in our industrial economy, it should be apparent that it is very difficult to identify optimum mixes of energy supplies and that there are no

obvious solutions. It is also hoped that the reader will appreciate the need to evaluate environmental effects as a critically important part of the task of designing least-cost energy supply systems.

The brief demonstrates that the one energy "source" that can be encouraged without fear of hidden side effects is conservation. Clearly, the use of energy is at the root of many environmental concerns and using less energy to provide the same level of service is almost always environmentally beneficial.

This publication is not intended to constitute a departmental position with respect to energy. Rather, it is a compendium that presents the information and data available to us at the moment. The search for new and better information and data will go on, and when the Department chooses to take a position or to make a point it will be on the basis of the best knowledge available at that time.

The document starts with the introductory statement that was made to the Parliamentary Committee by the Deputy Minister, Mr. J. Blair Seaborn. This is followed by the brief itself, which is the core of the document, and three supporting appendices. This document is the result of a lot of work by a large number of people throughout the Department of the Environment. It was compiled by D.G. Robinson and edited for publication by A.J. McIntyre.

Deputy Minister's Remarks to the Special Parliamentary Committee on Alternative Energy and Oil Substitution

I am very pleased to have the opportunity to present Environment Canada's views before the Special Parliamentary Committee. In view of a number of future energy options required to meet the future needs of Canada, I would like to focus particularly on the potential for energy from renewable resources. We believe that renewable sources of energy deserve serious consideration from the viewpoints of environment, economics, net energy generation and resource utilization.

Some General Considerations

The preparation of this submission was guided by the following considerations:

- i. The energy strategy for Canada should be formulated to support a mature sophisticated industrial society;
- ii. We should recognize the desirability of being more self-reliant in meeting our energy requirements;
- iii. The proposed energy options for Canada should be sustainable on a long-term basis both from the viewpoint of resource supply and the need to minimize stresses to the environment;
- iv. There is no single energy option applicable to the whole of Canada, nor would such a strategy be desirable. What we should aim for is a multiple-option, regionally-oriented energy supply (and use) strategy.

Energy and the Environment

In suggesting the above four critical elements of a Canadian energy strategy, we had in mind the interface between energy and the environment. That interface has at least three facets:

- The environment as a source of energy

- The environment as a receiver of impacts related to energy production and use
- The environment as a constraint in energy development and use.

First, renewable components of the environment provide opportunities to harness energy, in the form of wind and solar energy, and also in the form of forest biomass and hydraulic power. Such renewable sources of energy are particularly appropriate replacements for finite energy sources such as fossil fuels. Canada's rich endowment of certain renewable resources offers substantial potential for meeting future energy needs.

Secondly, exploration, processing, transport and utilization of energy results in environmental stresses. While the environment can readily assimilate stresses up to a certain level, stresses beyond this level can generate adverse and often irreversible environmental impacts. Some of the impacts such as air pollution in urban areas are immediate and quite apparent; others, such as climate change induced by CO₂ increases in the upper atmosphere, are more subtle and involve a longer time scale. There also can be substantial effects on other users of the affected environmental resources (air, water, wildlife, land, climate, etc.). Significant environmental and economic disruption can occur locally (e.g. due to oil spills, or the siting of a nuclear power plant), regionally (e.g. effects of acid rain on tourism in Central Ontario), or nationally and globally (e.g. CO₂, acid precipitation, climatic change).

Thirdly, climate and environmental conditions affect the availability and accessibility of energy sources. Hydro-power, the water cycle and forest biomass are mutually interdependent. The environment is a major constraint in exploiting northern and off-shore O11 and gas resources. Climate, in particular, influences energy demand; for example, a one degree fall in average annual temperature for locations in southern Canada will produce a 10% increase in energy used in space heating.

The close relationship between energy and the environment makes it imperative that opportunities offered by renewable resources and environmental capabilities, be given full consideration from the start in selecting and developing energy sources and technologies appropriate for Canada.

The Potential Role of Renewable Sources of Energy

With the exception of hydroelectricity, which already provides one quarter of our energy needs, Canada's diverse renewable energy resources are still largely unutilized. There is enough solar, wind, tidal, forest-biomass and hydro energy available in Canada to meet one third of the energy needs of our industrial society by the year 2000.

Our analysis (Table 3.2) shows that solar energy has an appreciable potential in southern Canada where population and industry is concentrated. Wind energy can be harvested along the east and west coasts, the Gulf of St. Lawrence, Hudson Bay and SW Alberta. Alternate sources of hydro (e.g. low-head, small scale), yet to be harnessed, are available throughout Canada. The off-shore regions of the east and west coast have been recognized to have potential in tidal and wind power. Biomass from the forests of the coastal B. C., southern Ontario and Quebec has an important potential for energy generation, either by direct combustion or by conversion to liquid fuels.

In many cases, the technology is already available in Canada or can be imported and adapted to Canadian conditions. In other cases, such as the use of salinity gradients in large rivers (e.g. St. Lawrence, Fraser and Mackenzie), technology is expected to be available only by the year 2050.

Many of these renewable sources of energy have already been put to use and their practicality has been demonstrated. Most of them are either environmentally benign or their significant environmental impacts can be mitigated through improved technological design and resource management practices. In the face of declining reserves of finite resources and demonstrable environmental problems flowing from fossil fuels, renewable resources appear very attractive. Furthermore, a greater utilization of Canada's renewable resources will provide economic benefits nationally, regionally and locally.

It should be recognized that some of these renewable energy sources are only appropriate for certain applications in Canada. The use of solar power for space heating, especially through the more systematic use of passive solar gain, and for hot water

in residences and commercial buildings, or the use of wind power in our more sparsely-populated areas seem practical. The transformation of forest-biomass to liquid fuels is also attractive particularly for transportation fuel.

While the most effective use of renewable energy will be to meet new energy needs in the industrial, transportation and residential sectors, it would be prudent to build new plants and facilities from the outset with renewable energy in mind. For instance buildings should be oriented to take maximum advantage of the sun. Sites uniquely appropriate for wind power plants should not be allowed to be used in ways that preclude later development. In general, new plants should either start on a renewable energy base or at least be able to change to renewable sources with a minimum of alteration or equipment replacement. Renewable energy should therefore figure prominently in industrial, economic and energy strategies at national and regional levels.

The justification for the development and use of renewable energy sources necessarily involves the consideration of costs and benefits in a broader context than is conventionally used in considering fossil fuels. Such factors as security of supply, environmental effects, capital costs, social impacts and net energy factors, among others, should be taken into account when evaluating and comparing the potential role of renewable sources with the conventional. If these same factors were considered for all energy sources, the advantages of renewable energy sources over non-renewables are likely to be much more apparent than is shown by the present accounting system.

Coal

With respect to the conventional energy sources coal is a particular source of concern. It exists in very large quantities and Canada has a very large share of the global resource. We are concerned that some efforts to solve the environmental problems that go with the use of coal could merely relocate the problem elsewhere. The liquefaction or gasification of coal is in this category in that the conversion plant tends to become the site of environmental problems rather than the thermal generating plant. The use of fluidized-bed combustion may reduce SO₂ emissions but it also creates solid wastes that must be disposed of and this has environmental implications. Problems created by acid rain, increases in global CO₂ levels, water demands for coal liquefaction and gasification and local pollution may substantially limit coal as a future energy source. While abundant sources of coal make it an attractive option, considerable R&D is required to minimize environmental problems associated with its production and use.

Energy Conservation

From virtually any point of view, energy conservation is an extremely attractive "source" of energy. Not only is it environmentally appropriate, it also reduces the demand pressures that are pushing fuel prices upward. This source is also of some considerable size. Projections made by EMR indicate that through conservation measures, we could reduce energy demand by about 1/3 by the year 2000. Again, if we consider the social benefits in terms of avoided environmental impacts incurred throughout the system, from extraction to use of conventional energy resources, conservation is the most attractive option available to us.

There is still a lot to be learned if we are truly to understand our energy resources. Not only are there gaps in the technologies available for extracting and using alternative energy sources, there are also many gaps in our knowledge of environmental implications. It is therefore essential that innovative energy-related Research and Development programs be fully supported.

Management of Energy Demands

Most discussions on energy in Canada have focussed on the supply side of the equation. I would like to address a few remarks on how we utilize energy in Canada and on management of this demand. As a nation, we are among the heaviest users of energy in the world. This situation is usually attributed to the large size of the country, sparse population, harsh climate and industrial use. Recent analyses show that Canadian industries, particularly industries based on natural resources, are very energy intensive. The same industries are also environmentally stressing.

While developing our energy (supply) strategy, we should also focus on the demand side and examine how we may economize on that side of the equation. Development of energy efficient, low- and non-waste and environmentally appropriate technologies in areas where Canada's natural resource based industries have a competitive advantage would be one important step in that direction.

Conclusion:

I would like to suggest that evaluation of various energy options should take into consideration such factors as sustained availability of resources in Canada, capital and energy inputs, environmental impacts and the use of the energy produced. An analysis based on these factors would show the benefits to be gained through the use of renewable sources of energy. We should also focus on managing the future demand for energy and encourage energy-efficient technologies and energy conservation. To sum up and to repeat, renewable resources, including conventional hydro, have a potential to contribute nearly one-third of the anticipated demand for energy by the year 2000. But planning must begin now if we wish to attain that goal.

There is no single energy option applicable to the whole of Canada, nor would such a strategy be desirable. What we should aim for is a multiple-option, regionally-oriented energy supply (and use) strategy that would change and evolve in tune with the development of new technologies and demands. This multiple-option path seems to be least vulnerable in a strategic sense.

J.B. Seaborn, Deputy Minister
Environment Canada,
November 13, 1980

Executive Summary

This submission reviews the potential of renewable resources to meet future Canadian energy needs and the more significant environmental implications of a number of energy alternatives being considered by the Committee.

The following are the highlights from this submission:

1. Canada's renewable energy resources such as solar radiation, wind, forest biomass and hydraulic power offer substantial, still largely unutilized, possibilities to meet diverse future energy needs of the country. Renewable energy resources could provide up to one third of the total energy used in Canada by the year 2000 (hydropower already provides 24%). It is only a matter of time before Canada will be forced to reduce its dependence on depleting sources of energy and to draw on its renewable resource base as the major source of energy supply to support an industrial society. Planned and positive steps in this direction should be taken now.

2. The most effective use of renewable energy will be to meet new energy needs in the industrial, transportation and residential sectors. A greater utilization of Canada's renewable resources will provide economic benefits nationally, regionally and locally. Renewable energy should, therefore, figure prominently in industrial, economic and energy strategies at national and provincial levels.

3. Although the development and use of some, but not all, renewable energy resources will result in environmental damage, most of the significant environmental impacts can be mitigated through improved technological design and resource management practices. Environmental implications are not expected to constrain to any significant degree the realization of the full potential of Canada's renewable energy resources. Renewable energy sources, as compared to the more conventional sources can be developed with less damage to the environment.

4. Canada has large reserves of coal. The use of alternative coal technologies (liquefaction, gasifica-

tion, fluidized bed combustion, etc.) may change the location, type and degree of environmental damage that would be produced through the conventional coal fuel cycle. However, any large-scale increase in the use of coal either by conventional or alternate means, would have serious environmental implications. Problems associated with toxic emissions, acid precipitation, global CO₂ levels, local pollution and water demands in water-short regions will substantially limit the rate and scale of developing coal resources. Pollution control measures such as flue gas desulphurization can relieve, but not entirely eliminate, these problems.

5. Alternative energy technologies which improve the efficiency of energy use (cogeneration, district heating, etc.), and thereby reduce the need to produce energy from fossil and nuclear fuels, are environmentally attractive. Alternative transportation fuels which reduce urban air pollution problems are also attractive. Their use as substitutes for gasoline should be encouraged, provided environmental impacts arising from the associated fuel and materials cycles are controlled.

6. In considering alternative renewable energy resources and technologies, social, economic, environmental, and net energy factors must be included in the analysis. If the same broad criteria are applied to analyses of both conventional energy sources and alternative renewable energy sources, the comparative advantages of renewable sources will become more apparent.

7. Research and Development strategies are important in the shift to alternative energy resources and technologies. R&D efforts must be selective and focussed on areas of technological development which will provide the greatest economic returns.

8. Energy conservation is the most environmentally attractive "source" of energy. It offers substantial possibilities for reducing dependence on depleting energy sources and provides good protection against rapidly escalating energy prices. Energy conservation should, therefore, be given full consideration as an energy supply alternative.

In summary, a substantially increased role for renewable energy resources and conservation is both practical and desirable on the basis of economic, environmental, net-energy gains and resource availability considerations. Environment Canada

therefore *recommends* that high priority be given to the development of renewable forms of energy and appropriate technologies, and to promoting energy conservation as the central components of Canada's future energy strategy.

The Energy Brief

1 Introduction

This submission reviews the energy potential of certain renewable resources on which the department has information that may be useful to the Committee's enquiry. The submission also identifies the more significant environmental implications of energy alternatives. The alternatives selected for consideration are those identified in the background information which describes the Committee's task. They include non-renewable, as well as renewable, sources of energy. Since the Committee's terms of reference preclude detailed study of hydro-electricity (large scale), nuclear fission, oil sands, natural gas and conventional coal technologies, these options have not been given particular attention in this submission. The submission concludes by offering the Department's perspective on factors which should be considered in selecting energy options, and on an R&D and energy strategy to meet Canada's future energy needs.

The energy-related activities of the Department include studies of the *resources* available as renewable sources of energy: solar and wind energy (Atmospheric Environment Service), hydraulic power (Environmental Conservation Service), forest biomass (Canadian Forestry Service) and municipal solid wastes (Environmental Protection Service). Information provided on resource potential (Section 3 and Appendix A) is limited largely to these areas.

Departmental activities associated with the development of renewable energy technologies concern mainly hydropower, forest biomass and solid wastes. The Department's mandate for environmental protection requires it to keep abreast of technological developments associated with both conventional and alternative fuels. Technological descriptions in this submission are brief and are restricted to the information necessary to support a brief discussion of environmental implications.

In view of the newness and, in some cases, speculative nature, of a number of the energy alternatives, some of the *environmental implications* are either uncertain or unknown. The submission draws on available knowledge to identify the major environmental implications, both positive and negative, of each alternative (Appendices A, B, C) and to provide a summary statement of their likely environmental significance (Section 4).

The submission by Environment Canada is relatively comprehensive, but not detailed. Descriptive and factual data have been generalized and aggregated in order to provide a perspective on the nature of the energy/environment relationship as it applies, in particular, to alternative energy resources. However, more detailed information can be provided to the Committee in response to a specific request,

2 Energy and the Environment — A Perspective

Energy and the environment interact with each other in several ways. First, components of the natural environment provide energy, not only in the form of wind and solar energy, but also in the form of forest biomass and hydraulic power. Such sources of energy are thought of as renewable and are therefore particularly appropriate replacements for finite energy sources such as fossil fuels. Canada's rich endowment of renewable resources offers substantial potential for meeting future energy needs.

While the assimilative capacity (capacity to absorb pollutants) of the environment up to a certain stress level is recognized, beyond this level the exploitation and use of both renewable and non renewable energy resources can generate irreversible and adverse environmental impacts. Some of the impacts are quite apparent such as air pollution in urban areas. Others are more subtle such as climatic change induced by CO₂ increases in the upper atmosphere. There can be substantial effects on other uses of the affected environmental resources (air, water, wildlife, land, climate, etc.). Significant environmental and economic disruption can occur locally (e.g. due to oil spills or

the siting of a power plant), regionally (e.g. effects of acid rain on tourism in Central Ontario), or nationally and globally (e.g. CO₂, acid precipitation, climatic change).

In turn, climate and environmental conditions affect the availability and accessibility of energy sources. Hydro-power, the water cycle and forest biomass are mutually interdependent. The environment is a major concern in exploiting northern and off-shore oil and gas resources.

The environment and, in particular, climate also affect energy demand. For example, a one degree fall in average annual temperature for locations in southern Canada will produce a 10% increase in space heating energy demand (1).

The close, two-way relationship between energy and the environment makes it imperative that environmental capabilities and factors be given full consideration from the start in selecting and developing energy sources and technologies.

3 potential of Alternative Energy Resources

This section discusses the energy available from alternative energy resources. A more detailed discussion of individual sources including comments on environmental impacts is presented in Appendix A. Energy conservation, which is considered to be analogous to an energy source, is discussed in Section 5.

Many, but not all, alternative energy resources are "renewable". Renewable resources are those resources whose potential, although finite, is virtually inexhaustible (e.g. solar radiation, wind, hydropower, tidal, wave, and ocean gradients) or replenishable within a reasonably short time period (e.g. forest biomass). Municipal solid wastes are also renewable, provided people keep "producing" garbage. Geothermal heat may also be considered renewable as its heat source is much larger than any feasible human exploitation, but such may not be the case for specific geothermal sites. Peat is not renewable in itself, although a particular site may be used to grow biomass after the peat has been extracted. For convenience in this review, all of the energy alternatives discussed in Appendix A are considered to be renewable resources.

The full energy potential of Canada's renewable energy resources has begun to receive attention only recently. In several cases, associated technologies are new or unproven in the Canadian context, and estimates of their potential are only tentative. However, one can make several general statements concerning the availability of renewable resources to meet Canadian energy needs.

1. Renewable resources are a practical alternative to oil and other conventional energy sources and they can play a significant role in an oil substitution program. Renewable energy resources such as forest biomass, hydropower, solar radiation and wind could meet most future transportation, heat, and electricity needs in both urban centers and less populated regions of the country. As with any resource, the amount of energy available depends on the price, the efficiency of the technology, and the time required for development. Given concerted priority through R&D funding, tax and other financial incentives, and the removal of major institutional barriers, it would not be

unrealistic to see renewable energy resources, excluding conventional hydropower, providing up to 200% of Canada's total annual energy needs by the year 2000 (Table 3.1). If the potential for conventional hydropower is included, the contribution of renewable energy resources could exceed one third of total energy consumption by that time (taken as 1470×10^6 bbls oil/year).

2. The energy available from renewable sources is widely dispersed geographically (Table 3.2). Thus, unlike most non-renewable energy resources, renewable sources of energy can be developed in the region of energy demand. This has obvious implications in equalizing opportunities available to all regions of Canada to share in the economic benefits that may be associated with energy resource development. It also has implications related to the transportation or transmission of energy. Because of their dispersed nature, renewable resources also offer considerable advantages as sources of energy for the many small and isolated communities in Canada which currently face very high energy costs,

3. Supply cycle characteristics (Table 3.2) vary greatly among renewable energy alternatives. Solar energy fluctuates daily, seasonally (radiation for the worst winter month can be 1/6 of that for the best summer month) and according to local climate and weather, but within generally known limits. Wind energy also has considerable daily and short term fluctuations, but is generally less variable than direct solar energy on a longer term basis. Energy production from other renewable resources is less variable than are solar and wind sources. Problems of supply fluctuations can be mitigated through the use of energy storage systems and by drawing on various mixes of energy supply alternatives which, in aggregate, smooth out energy supply over time.

4. There is a limit, determined by natural processes, to the rate at which renewable resources can be used or harvested. For solar energy, the limiting rate is fixed by the amount of incoming solar radiation; for hydropower, by the amount of water flowing in streams and by the stream gradient; and for forest biomass, by the rate of forest growth. Forest biomass is not renewable

on a sustainable basis if the rate of exploitation exceeds the rate of natural replenishment. Replenishment limits must be respected if the rate of exploitation is to continue on a sustained basis. Wise resource management can often enhance replenishment rates through, for example, intensive forest management or energy plantations.

5. The state of technology varies greatly among renewable energy alternatives. Although some renewable energy technologies are reasonably well developed in certain other countries, they are new to Canada and required adaptation and demonstration in the Canadian context. Examples include tidal power, methanol production from forest biomass,

fluidized bed combustion for municipal solid waste, geothermal energy, and peat combustion. Technologies associated with most solar and wind energy alternatives are relatively new to North America. Considerable research, development and demonstration is required to realize the full potential of Canada's renewable energy resources.

6. Unexploited renewable energy sources can most readily be used to meet new energy needs or increases in energy demands of particular sectors. The energy needs of new industries, expanded transportation systems and new housing can be matched to available renewable resources in a manner which is both energy efficient and more economic than through retrofitting.

TABLE 3.1

ESTIMATES OF ANNUAL ENERGY THAT COULD *REASONABLY* BE EXPECTED
FROM RENEWABLE RESOURCES AND ENERGY CONSERVATION BY THE YEAR 2000

ENERGY SOURCE	DATA SOURCE	AMOUNT OF ENERGY PER YEAR (bbls of oil equivalent x 10 ⁶) ^a
Solar Radiation:		
passive solar	NRC	29 (1)
domestic hot water	NRC	2 (2)
ind. process heat	NRC	15 (2)
space heating		3 (2)
Solar sub-total		49
Wind	NRC	3 (3)
Alternate Hydro (small scale, etc.)	DOE	20 (4)
Tidal	DOE	24 (5)
Wave	DOE	Nominal
Ocean Gradients	DOE	Nil
Biomass (forest) to Methanol	DOE	180
Municipal Solid Wastes	DOE	7
Geothermal	NRC	Nominal
Peat	EMR	.5 (6)
Sub-total		283.5
Conventional hydropower		353 (7)
Total from renewable sources by 2000		636.5

TABLE 3.1, CONTINUED

(1) Ref. NRC Presentation to the Special Committee, July 9, 1980, p. 11 — 2% of National Energy Use — taken as 1470 x 106 bbls oil/year for the year 2000.

(2) Ibid — assumed 10% of the potential quoted would be achieved by 2000.

(3) Ref. NRC Presentation to the Special Committee, July 2, 1980, p. 13 — Tabulation gives 20 PJ (petajoules) by 2000.

(4) Best available estimate of alternate hydro potential is 180 million bbls oil/year. It was assumed that about 10% of this would be developed by 2000.

(5) This assumes that the oil would be used in a conventional thermal generating plant to produce the same electricity available from tidal power.

(6) Private communication from Coal and Peat Resources Evaluation Branch, Energy Research Laboratory, EMR,

(7) The 1980 National Energy Program says that hydro now contributes 24% of Canada's energy. This same ratio was assumed to apply in 2000.

(8) Private communication from Conservation and Renewable Energy Branch, EMR.

•Note:

(a) *The figures used are indicative only and in many cases will require further analysis, Actual availability obviously will depend on many factors.*

(b) *The basis of barrels of oil equivalent has been used for convenience. It should not be assumed that direct substitute for oil is possible in every case.*

Energy conservation goals for 2000":

- space heating	221	bbls of oil equivalent x 106 per year
- industry	180	"
- transportation	43	"

Total from conservation 444

•Source:

Private communication from Conservation and Renewable Energy Branch, EMR.

Note:

Due to possible overlaps and mutual interrelationships (direct and indirect) between the use of renewable energy resources and the conservation of energy, the above 2 sets of figures should *not* be added. The actual total of the contribution is probably significantly less than the addition of the 2 respective contributions would indicate.

TABLE 3.2
POTENTIAL OF ALTERNATIVE ENERGY RESOURCES

Note: The environmental implications of these alternatives are summarized in Table 4.1

RESOURCE	GEOGRAPHIC (LOCATIONS OF GREATEST POTENTIAL) AND SUPPLY CYCLE CHARACTERISTICS	STATE OF TECHNOLOGY	MAJOR END USE APPLICATION VIS A VIS MARKET (MATCHING SUPPLY TO DEMAND)	ESTIMATES OF ENERGY POTENTIAL (BARRELS OF OIL EQUIVALENT; ANNUAL BASIS)
Solar radiation	<p><i>Geographic:</i> Across southern Canada, up to 55° N. latitude.</p> <p><i>Supply Cycle:</i> Regular daily and seasonal fluctuations (radiation for worst winter month can be 1/6 of that for best summer month).</p> <p>Fluctuations affected by local climate and weather (cloud cover, etc.) and by air pollution.</p>	<p>Relatively new in a Canadian context.</p> <p>Passive solar building design, materials durability, and storage (short and long term) are important areas for R&D emphasis in a Canadian context.</p>	<p>Space and water heating (active and passive):</p> <p>Geographic match is good.</p> <p>Supply cycle match is poor (highest demand is in winter when radiation is least), therefore storage or backup is required.</p> <p><i>Electric Power:</i> (photovoltaic) As above.</p>	<p>NRC (1980) estimates:</p> <p>Passive solar: 20/0 of total national energy consumption (TNEC) by 2000 (additional to 120/0 current).</p> <p>Domestic hot water: potential impact 1 1/2% of TN EC.</p> <p>Industrial process heat: potential impact of 1 0% of TNEC.</p> <p>Space heating: potential impact of 2% of TNEC.</p>
Wind	<p><i>Geographic:</i> East cost, Gulf of St. Lawrence, Hudson Bay and S.W. Alberta.</p> <p>Numerous local pockets of high potential across the country.</p> <p><i>Supply Cycle:</i> Energy generally available on year round basis with much less seasonal fluctuation than for solar.</p> <p>Short term fluctuations (daily, weekly) can be substantial.</p>	<p>Relatively new in a Canadian context (except for windmills).</p>	<p><i>Electric Power:</i> Good potential for coastal regions and for smaller communities with local wind pockets.</p> <p>Especially attractive for off-grid communities but storage or backup is essential.</p>	<p>300 million barrels (60,000 MWh) potential (optimistic scenario by Templin of NRC).</p> <p>3.3 million barrels (20 x 10¹⁵ Joules) for the year 2000 (NRC projection, 1980).</p>

Alternate hydro	<p><i>Geographic:</i> Alternate hydro is available throughout Canada.</p> <p>Quebec, B. C., Alberta and north of 60° are areas of greatest undeveloped <i>total</i> hydropower potential (breakout for alternate hydro not available),</p> <p><i>Supply Cycle:</i> Can be substantial seasonal fluctuations due to e.g. spring run-off, summer dry spells.</p> <p>Fluctuations due to climatic factors can be significant (e.g. prolonged drought).</p>	Technology is relatively mature.	<p><i>Electric Power:</i> Good potential for many small communities, especially "off-grid" communities.</p> <p>Fluctuation problem can be substantially overcome through dam and pumped storage (also hydrogen and battery storage may become feasible).</p> <p>Significant potential to supply grid either for base load or peaking demands,</p> <p>Sites that are remote from both grid and demand centres may eventually be feasible sites for hydrogen production.</p>	180 million barrels, assuming only one-half of the present hydropower capacity represents the potential for alternate hydro.
Tidal	<p><i>Geographic:</i> Bay of Fundy Region.</p> <p><i>Supply Cycle:</i> Daily tidal cycle permits harnessing of incoming and out-going tides.</p> <p>Relatively constant and completely predictable source of power seasonally and annually.</p>	<p>Technology is reasonably advanced and no major technological problems exist,</p> <p>Demonstration in a Canadian context and some development is required,</p>	<p><i>Electric Power:</i> Good potential for Maritime Region.</p> <p>On the basis of systems studies, the output from the Bay of Fundy development can be absorbed without difficulty into the utility grid.</p>	24 million barrels (16 x 106 Mwh) by 2000 for total Bay of Fundy potential considered economically feasible (25% of this amount could be available by early 1990's).
Wave	<p><i>Geographic:</i> East and west coast off-shore regions,</p> <p><i>Supply Cycle:</i> Fluctuation with wave frequency,</p>	Technological development is being initiated elsewhere.	Electric Power:	Only limited commercial application for Canada.
Ocean thermal energy gradients (OTEC)	Likely not feasible for Canada.	No producing plants yet, U.S. is developing OTEC technology,	Electric Power:	Likely little if any commercial application for Canada but will be international potential,
Salinity gradients	Large estuaries, e.g. St. Lawrence, Frazer, Mackenzie.	Technology could be available by the year 2000.	Electric Power:	Only long term potential for Canada.

TABLE 3.2, CONTINUED
POTENTIAL OF ALTERNATIVE ENERGY RESOURCES

RESOURCE	GEOGRAPHIC (LOCATIONS OF GREATEST POTENTIAL) AND SUPPLY CYCLE CHARACTERISTICS	STATE OF TECHNOLOGY	MAJOR END USE APPLICATION VISA vis MARKET (MATCHING SUPPLY TO DEMAND)	ESTIMATES OF ENERGY POTENTIAL (BARRELS OF OIL EQUIVALENT; ANNUAL BASIS)
Biomass	<p><i>Geographic:</i> Greatest biomass productivity is in coastal B. C., and southern Ontario and Quebec.</p> <p>Greatest unused potential is in Prairie Provinces and currently there is much poor agricultural land available for intensive forest biomass production in Ontario.</p> <p><i>Supply Cycle:</i> Supply does not fluctuate as with solar, wind, etc.</p> <p>But regeneration cycle is long term (years or decades).</p>	<p>Technology for forest biomass harvesting and combustion is advanced, but clean combustion wood stoves in particular require further development.</p> <p>Technology for methanol production exists elsewhere and can be adapted to the Canadian context.</p> <p>Techniques for energy plantation management require development in a Canadian context to ensure soil nutrient depletion does not occur and wildlife habitat is not harmed.</p>	<p><i>Industrial Process Heat:</i> Greatest potential for forest industry.</p> <p><i>Space and Water Heating:</i> Good potential for smaller urban and more remote communities.</p> <p><i>Electric Power:</i> Cogeneration has good potential for forest industry.</p> <p>Centralized electric power production into the grid would be particularly attractive for peaking duty,</p> <p><i>Transportation:</i> Good potential for substituting liquid fuels (e.g. methanol) for gasoline.</p>	<p>300 million barrels by the year 2000 from biomass currently available (assuming biomass price increases and technological advancement). Long-term potential much higher.</p> <p>180 million barrels (equivalent) of methanol by year 2000.</p>
Municipal solid wastes	<p><i>Geographic:</i> Greatest availability in large urban centres.</p> <p><i>Supply Cycle:</i> Some fluctuation in availability from week to week and possibly seasonally.</p>	<p>Technology is reasonably mature but requires further development and demonstration in a Canadian context.</p> <p>Fluidized bed combustion for smaller scale applications requires development.</p> <p>Technology exists in the U.S.</p>	<p>Industrial Process Heat:</p> <p>Electric Power:</p> <p>District Heating:</p>	<p>19 million barrels (total for 163 Canadian municipalities, assuming a 75/0 conversion efficiency and total use of the solid waste stream).</p> <p>Between 5.7 to 9.5 million barrels is a reasonable estimate of usage for the year 2000.</p>

Geothermal	<p><i>Geographic:</i> Rocky Mountain region of Canada.</p> <p><i>Supply Cycle:</i> Supply Cycle variation possible over longer term, if heat source is "drawn down" too rapidly.</p>	Technology exists in the U.S.	<p>Industrial process heat for industries on site.</p> <p>Space heating for communities located close to source.</p> <p>Electric power generation.</p>	<p>Estimate for total geothermal reserves in Canada is astronomical.</p> <p>Only nominal use expected by 2000.</p>
Peat	<p><i>Geographic:</i> Ontario, New Brunswick and Manitoba, but substantial peat also exists in Quebec, B.C. and Newfoundland,</p> <p><i>Supply Cycle:</i> No supply cycle variation except over longer term as bogs get mined out.</p>	<p>Technology is relatively mature in other countries (Ireland, Finland and U.S.S.R.).</p> <p>Harvesting methods need to be developed for Canadian conditions.</p>	<p>Space and industrial process heat for communities close to the site.</p> <p>Electric power for grid and for communities off the grid.</p>	717.5 million barrels (531 million tons) is estimated to be the total peat reserves in Canada.
Energy conservation	<p><i>Geographic:</i> Potential exists virtually everywhere that energy is used.</p> <p>Greatest potential appears to be in the residential and transportation sectors.</p> <p><i>Supply Cycle:</i> No fluctuation problem</p>	Energy efficient building design, transportation and industrial processes have only recently been given priority,	<p>Space heating.</p> <p>Industrial process heating.</p> <p>Electric power use</p> <p>Energy supply industry</p> <p>Transportation.</p>	<p>For the year 2000 (EMR estimates considered reasonably achievable; prepared in isolation of each other):</p> <p>Buildings -221 million barrels</p> <p>Transportation -43 million barrels</p> <p>Industry -180 million barrels</p>

4 Environmental Implications of Energy Options

Alternate energy sources and technologies have widely varying environmental implications, ranging from mainly beneficial or benign, to substantially damaging (Appendices A, B and C). Table 4.1 summarizes the major environmental implications, both positive and negative, of each alternative and notes those impacts which may be limiting with respect to the realization of the full energy delivery potential of the alternative resource or technology. Limitations can be in terms of (i) location (in regard to environmental sensitivity or other uses of the environment), (ii) scale, or (iii) rate of energy production or use. Limitations can occur in the form of regulations, decisions by environmental assessment panels, societal resistance or high costs.

In spite of the differing nature of the environmental impacts, some generalizations can be made. In order to provide a uniform basis for comparison, the following generalizations are based on equivalent levels of energy output.

1. A distinction must be made between those sources of energy which have fuel cycles (involving fuel extraction and transport, and post-combustion waste disposal as well as combustion or conversion) and those that do not. Non-renewable sources (e.g. oil, gas, coal and nuclear-uranium) and certain renewable resources (e.g. municipal waste, biomass) involve fuel cycles. Other renewable energy sources, such as hydraulic, solar and wind, do not. The processes associated with fuel cycles can place a substantial burden on the environment. This is particularly the case for fossil fuels, which are often extracted at locations far removed from the point of conversion and use. Fuel cycle impacts would be limiting for certain non-renewable resources.

2. Although renewable energy derived from solar, wind and hydraulic sources does not involve a fuel cycle, environmental impacts can be significant in certain cases:

- The diffuse nature of solar and wind energy may require large land areas for centralized energy conversion. The problem can be partly relieved by multiple purpose land use and decentralized conversion (e.g. solar panels on roof tops).

- The material and energy requirements of components used in the manufacture of solar panels could account for emissions, effluents and wastes approaching the same order of magnitude as those from a conventional coal-fired plant operating over several years. Recycling of materials, new materials requiring low energy inputs, and proper pollution control measures for production processes can limit the environmental effects in ways not possible with coal,

- Large scale hydropower developments can require substantial material (e.g. for dam structures) and can flood fertile river valleys. Tidal and hydropower structures may also be disruptive to water regimes, affecting waterfowl breeding and aquatic life. These effects can be limiting in some locations. Similar effects from small scale hydro and wave energy developments are minimal.

- Technologies to tap ocean thermal and salinity gradients on a large scale could have important environmental effects if the ocean circulation or chemistry were disturbed near biologically productive areas.

3. The conventional coal fuel cycle (including mining, upgrading, transport, combustion and disposal) causes substantial land, air and water impacts. Problems associated with acid precipitation, global CO₂ levels and local pollution will limit exploitation of the full potential of coal resources. Alternative *technologies* may change, but will not mitigate these environmental effects:

- coal gasification and liquefaction, in effect, displace the environmental effects of combustion from the point of power generation or use to the point of extraction or conversion (water supplies may be a limiting factor in western Canada);

- fluidized bed combustion, a developing technology, should reduce to some degree emissions of SO_x and NO_x which are the two principal contributors to acidic precipitation. However, particulate emissions may be greater and disposal of spent bed materials may present substantial problems;

- the increased efficiency of magnetohydrodynamics (MHD) and combined cycle processes would reduce the net fuel cycle effects of coal-based energy production. However, increased NO_x and fine particulate emissions from MHD are of concern and abatement equipment must be implemented as part of the initial installation;

- the effects of hybrid fuel combustion will depend on the mixes employed.

In the case of all coal combustion or conversion technologies, SO_x emissions can be relieved (but not totally eliminated) through the use of currently available flue gas desulphurization systems.

4. To the extent that co-generation, district heating and heat pumps improve the efficiency of energy use and reduce the need to extract and burn fossil fuels, environmental benefits will accrue.

5. The substitution of alcohols, propane and electricity for gasoline in transportation can contribute to improved air quality in urban areas. However, the use of diesel engines would increase carcinogenic emissions and thus increase health risks. A return to

leaded gasoline would set back many of the gains in improved air quality that were achieved over the last decade through the introduction of lead-free gasoline.

6. The most attractive alternatives from an environmental point of view are passive solar, decentralized solar thermal and photovoltaic, wind, small scale hydro, wave, hydrogen produced from environmentally benign processes, technologies which improve energy efficiency such as co-generation, district heating and heat pumps, and transportation fuel substitutes that can be produced from sources and by technologies that cause relatively little environmental disruption. Good environmental design and careful site selection will be necessary for renewable such as biomass, tidal, and geothermal. Nuclear fusion, when available, promises to be an environmentally attractive source of centralized power, but its expected benign features have yet to be proven in full scale operation. From both an energy and resource conservation point of view, recycling of municipal wastes would be more environmentally attractive than burning them, if such reuse reduces the need to mine and process virgin materials. Both conventional and alternate coal conversion technologies remain a serious environmental concern.

TABLE 4.1
SUMMARY OF MAJOR ENVIRONMENTAL IMPLICATIONS OF ENERGY ALTERNATIVES

Note:

Asterisk (*) indicates the environmental implication could be limiting i.e. it could significantly limit the realization of the *full* energy potential of the alternate.

ENERGY ALTERNATIVE	MAJOR ENVIRONMENTAL IMPLICATIONS
ALTERNATIVE RESOURCES	
Solar-passive	-Very benign, but puts constraints on land use planning through special requirements for street and site orientation, as well as building height restrictions to ensure solar access.
<i>Active:</i> Decentralized (thermal and photo-voltaic)	-Generally benign, but cumulative impacts from materials production may be significant. -Puts constraints on land use planning to ensure solar access.
<i>Active:</i> Centralized (thermal and photo-voltaic)	-Significant land requirements, especially of high capability agricultural land on the edge of large urban centres.* -Waste heat (for thermal plants only). -Cumulative Impacts from materials production may be significant.
Wind-decentralized	-Generally very benign, but visual and noise factors may be a local problem.
Centralized	-Land requirements, but these can be mitigated through multiple use, -Visual and noise problems may be significant, -Above 2 factors do not apply for offshore wind farms.

Alternate hydro-electric (small scale, low head, micro)	-Generally very benign, if carefully designed to minimize disruption to the bio-hydrological regime.
Tidal	-Impacts on fish and other marine biota, and sedimentation may be substantial, depending on site location, scale, design, etc. ● -No major environmental or social problems foreseen that would limit development at economic Fundy sites.
Wave	-Impacts will depend on technology used, but likely will not be substantial,
Thermal (OTEC) gradients	-Large scale OTEC operations could have significant effects on local marine ecosystems, could alter ocean flow patterns and surface temperatures, and could significantly affect climate on a local and possibly global basis. It is premature to judge the significance of these effects.
Salinity gradients	-Harnessing salinity gradients would have substantial requirements for fresh water and could seriously disrupt estuarine ecosystems, "
Forest biomass	-Intensive forest management practices, including energy plantations and whole-tree harvesting, could deplete productive potential of the soil and substantially alter forest ecosystems, ' -Use of high capability forest lands that could also be used for other forest products (e.g. pulp and paper) or, in some cases, agricultural production. -Combustion in large quantities would create air pollution and waste disposal problems in local areas, -Widespread use of wood stoves in concentrated urban areas will affect air quality substantially unless significant reductions in emissions can be achieved. *
Municipal solid wastes	-Energy from wastes is beneficial to the extent that it reduces the solid waste disposal problem and the use of more environmentally damaging fuel cycles. -Organic compounds in air emissions and fly ash have potentially serious health implications, unless precursor materials are separated out before burning. ' -However, recycling of cellulosic wastes, to the extent it obviates the need to extract and process virgin materials and produces net energy gains over virgin materials, is more attractive than burning such wastes.
Geothermal	-Closed system (reinfection, etc.) power generation and heat exchange processes should be generally benign, provided contamination of ground water can be avoided. -Risk of local land subsidence and seismic disturbances, depending on process (reinfection or not) and location. -Releases of noxious gases, corrosive brines, and waste water in open processes (non-reinfection) can affect local and long range air quality, and seriously affect surface and ground water quality. *
Peat	-If extraction of peat is not done carefully, irreversible damage can result to local ecosystems in fragile areas e.g. Hudson Bay Lowlands, ' -Extraction reduces a carbon sink and combustion adds to the CO2 problem. * -Combustion in large quantities would create air pollution and waste disposal problems in local areas. '
ALTERNATIVE TECHNOLOGIES	
Coal gasification and liquefaction	-Significant water demands in water short areas such as Western Canada may be limiting, ' -The necessary very large scale extraction and conversion operations can cause serious damage to local water and land environment, and add to acid precipitation problem. * -Combustion of resulting syn-fuels will contribute to global CO2 problem. ●

Fluidized bed combustion	<ul style="list-style-type: none"> -FBC can substantially reduce SO₂ and NO_x emissions, the two main ingredients in the formation of acid precipitation. -Disposal of solid wastes (spent sorbent) may be a substantial problem. † -Particulate emissions could be a problem,
Magnetohydrodynamics	<ul style="list-style-type: none"> -The increased efficiency of MHG over conventional coal power generation is environmentally attractive in that it decreases coal requirements for an equivalent amount of electric power produced. -However, NO_x and fine particulate emissions could cause problems. †
Hybrid fuel combustion	<ul style="list-style-type: none"> -Significance of effects will depend on the mixes used. Reduced emissions are likely, relative to straight coal or oil mixes.
Hydrogen and fuel cells	<ul style="list-style-type: none"> -The use of hydrogen is environmentally benign, but the risk of explosion must be considered. -Production of hydrogen can have substantial environmental impacts due to fuel cycle impacts of, for example, fossil and nuclear power sources. * -Use of renewable sources - solar, wind, tidal, wave and hydro - especially off peak hydro-electric – to produce hydrogen would cause less environmental disruption than the use of non-renewables.
Fusion	<ul style="list-style-type: none"> -Promises to be generally benign, -Some risk of local chemical damage in event of malfunction, -Environmental effect of production and fabrication of large quantities of new high temperature alloys is unknown, -Small amounts of mainly short lived radioactive materials have to be managed on shut-down. -Offers ultimate potential, yet unproven, of transmuting dangerous radioactive wastes into harmless material,
IMPROVED EFFICIENCY & INTERFUEL SUBSTITUTION	
Co-generation	<ul style="list-style-type: none"> -Very attractive to the degree that the increased efficiency substitutes for the use of fossil or nuclear fuels, and reduces waste heat problems.
District heating	<ul style="list-style-type: none"> -Same as for co-generation, To be cost-effective, requires medium to high-density urban development and the planning regulations to achieve such,
Heat pumps	<ul style="list-style-type: none"> -Very attractive to the degree that they make more efficient use of centrally generated electricity.
Alternative transportation fuels:	
Alcohols (Methanol, ethanol)	<ul style="list-style-type: none"> -Very attractive in terms of the reduction in air emissions over those from gasoline. -But problems could arise from fuel cycle impacts of the energy source (coal, forest biomass, etc.). †
Propane	<ul style="list-style-type: none"> -Very attractive in terms of the reduction in air emissions.
Diesel	<ul style="list-style-type: none"> -Carcinogenic emissions could be a serious health problem. *
Leaded gasoline	<ul style="list-style-type: none"> -A return to leaded gasoline would have serious environmental and health effects, particularly in urban areas. †
Electricity	<ul style="list-style-type: none"> -Very attractive in terms of reducing urban emission levels from transportation. -Enables environmental problems to be concentrated at a few power plants where they are more easily dealt with, -The impacts of an increase in electric power generation could be substantial but such an increase could be mitigated by using off-peak sources. *

5 Conservation — An Energy Alternative

Energy conservation makes eminent good sense. As a “source” of energy, conservation has several advantages relative to other alternatives.

- (i) it reduces the need for fuel extraction, transportation, conversion and utilization and their corresponding impacts on human health and the environment;
- (ii) it takes pressure off capital markets by reducing the need to finance large and expensive new energy developments;
- (iii) it permits more time for rationalizing energy developments and developing new energy alternatives; and
- (iv) it provides economic and environmental benefits in perpetuity; however, the value of future benefits arising from energy conservation tend to be heavily discounted, particularly in times of high inflation, and often go unrecognized.

Energy conservation has other economic effects such as shifting employment and investment from frontier regions to the point of use — the city, the rural community, etc. But its most attractive economic benefit is the relief it provides against escalating energy prices.

Canada's energy production and consumption pattern contains much waste and inefficiency. This pattern has become institutionalized into society by decades of ready access to cheap, abundant, and high quality energy sources — oil in particular. Figure 5.1 illustrates that theoretically over one-half of the energy produced in Canada in 1974 was discarded. The figure also shows that significant opportunities exist for conservation in every use sector, most notably in residential and transportation uses. Table 3.1 of section 3 shows the goals for savings from energy conservation over the next 20 years to be close to one third of total national energy consumption,

Individual conservation actions, whether motivated for economic or moral reasons, are not enough.

Thermostats can be turned down and smaller cars produced, but waste will continue for many years without a concerted, comprehensive and sustained effort toward more conserving energy use patterns (1). Measures such as education, incentives, removal of barriers to conservation, regulation, and “correction of market signals” to reflect realistic energy supply and demand situations all will be required to ensure success and to reduce the possibility of the imposition of stringent conservation measures.

Land use patterns are a major determinant of energy use, particularly in the transportation sector. Transportation consumes 40% of Canadian energy when indirect as well as direct consumption is considered, and most of this amount is derived from petroleum. High priority should be given to energy conserving land use planning strategies. A recent study and a subsequent national conference on energy conservation through land use planning, which were supported by Environment Canada, emphasized the importance of adopting such strategies (2, 3),

The possibilities for substituting communications for transportation should be exploited. Canada has substantial expertise in communications technology and certain communications aspects of space technology. This competitive advantage could be exploited to meet the dual goals of energy conservation and economic development,

Space heating is another major energy use, (about 30% of total energy consumption). The energy we use for space heating is a response to the Canadian climate and to established practices of building design and settlement patterns. More insulation of buildings is only a partial solution to the waste of energy in space heating. Climatic and environmentally appropriate materials use, building design and building siting should be promoted. More work is also required on the concept of urban “ecoplanning” which includes, among other factors, the use of natural features (vegetation, terrain) for shelter, temperature and noise moderation, and air purification. Heliothermic (helio = sun) planning and the exploitation of microclimates in community and building design also offer opportunities for reducing space heating and cooling requirements (4).

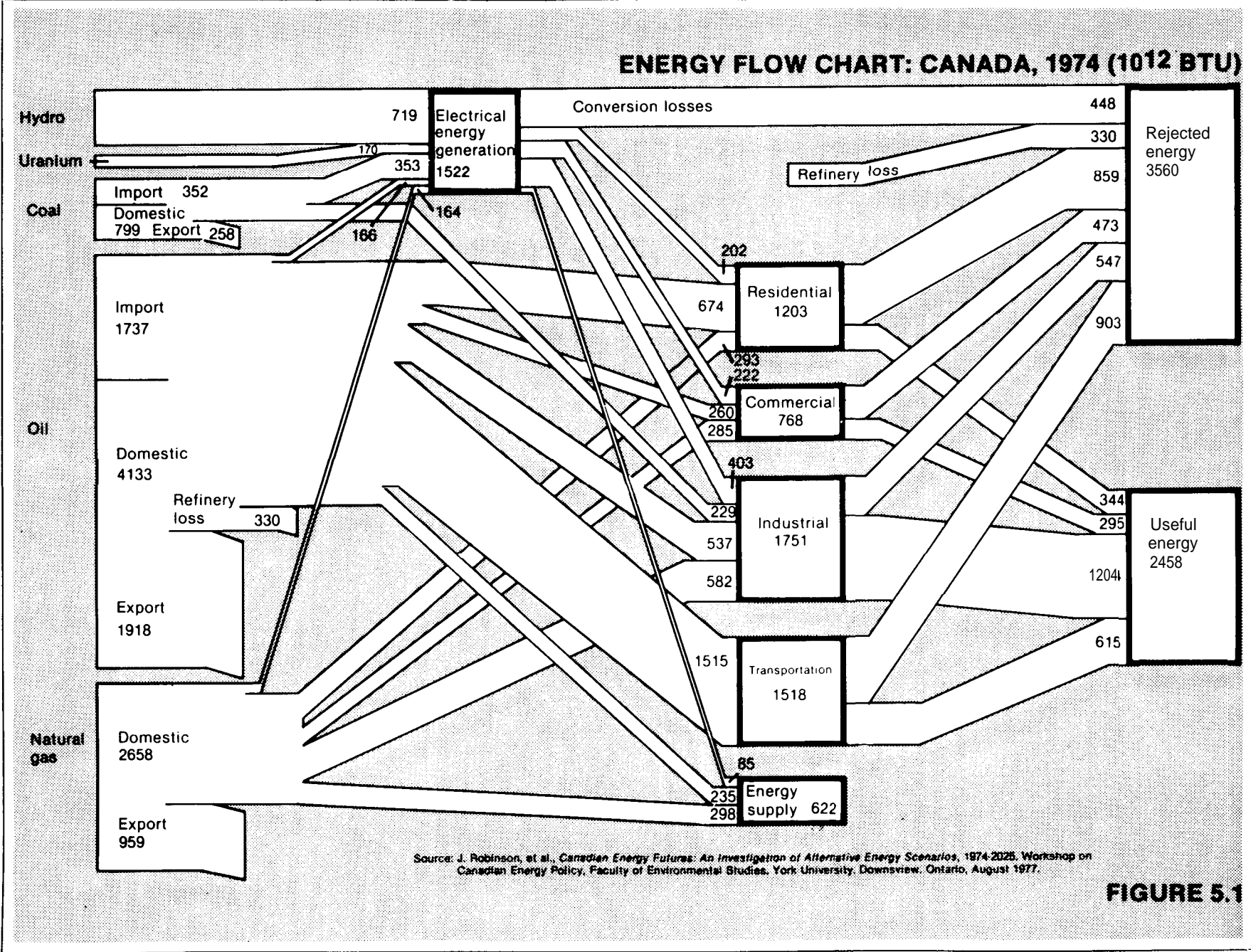

A concerted Program to encourage the recycling and reuse of currently wasted materials and products from municipal, industrial and agricultural sources would also conserve energy and provide environmental benefits. In addition, 150/0 savings in agricultural energy use are possible simply by timing the application of fertilizer better with relation to rain storms.

Work in new fields associated with biotechnology also has potential energy implications. New techniques for conventional processes such as fertilizing crops, separating metals from ore, and processing natural cellulose promise to reduce drastically agricultural and industrial energy demand. Environment Canada currently is investigating biological nitrogen fixation as an alternative to chemical fertilizers. The results to date are very promising.

* In figure 5.1 the relative waste energy/useful energy ratios, particularly in the residential sector, may have decreased since the mid-1970's when this Energy Flow Chart was published due to conservation practices and programs which have taken place since that time.

Higher prices for oil will encourage measures such as materials recycling and energy-efficient land use planning, as well as the development of renewable energy alternatives such as solar and biomass. But the price mechanism is subject to distortions which limit its use as an instrument for achieving the substantial energy savings that are possible through conservation. Today's domestic energy prices fail to give full recognition to the value of depleting resources and to the intangible aspects of environmental quality. The price mechanism is also a blunt instrument which tends to hit the less advantaged sectors of society the hardest. A comprehensive long-term oil substitution policy is required which incorporates an oil pricing policy in concert with appropriate consideration for vulnerable components of society. Such a policy must also facilitate the development of new energy supply alternatives through incentives and the removal of barriers, and it must emphasize institutionalizing energy conserving patterns into all facets of society and the economy—transportation, land use planning and building design, materials production, and industrial processes.

6 Selecting Energy Options: Factors For Consideration

This section briefly reviews factors which are considered important by Environment Canada in making choices regarding alternative energy sources and technologies. It is important that selection criteria include the total costs and total benefits of each energy option, whether tangible or intangible.

6.1 Energy Conservation as an Option

The "energy crisis" has generally been viewed as a problem of supply. One way to reduce the energy supply program is to promote factors which lead to reduced energy demand. Demand factors and energy conservation have not received the same level of attention as have supply factors in Canada, in spite of the fact that we have one of the highest per capita energy consumption rates in the world. Energy conservation should be given high priority and its potential as an energy "supply" source should be considered along with, and on the same basis as, other energy supply options in both short and long term energy planning. Generally speaking, energy conservation is the most environmentally appropriate energy option. It also has a number of attractive social and economic features (Section 5).

6.2 Renewable Resource Potential

The availability of an energy resource over time and space is a critical factor in determining the feasibility of its development. Some general observations can be made on factors which distinguish renewable resources from non-renewable resources.

As sources of energy, renewable resources have both advantages and disadvantages. They generally are diffuse sources, requiring special concentrating technologies to meet the energy intensive needs of an industrialized nation such as Canada. However, their diffuse nature can be advantageous. Energy supply systems can be tailored to meet the needs of specific markets, whether at the provincial, community, individual factory, or household level.

The renewability of resources such as solar, wind and hydro power generally is not affected by exploita-

tion. However, the renewability feature of forest biomass (and possibly the most easily exploited geothermal sites) will be lost if exploitation rates perpetually exceed replenishment rates. The finite nature of biomass productivity must be respected to ensure sustainability.

Another important feature of some renewable is their cyclic variability (daily, seasonally, annually, etc.). This problem can be reduced through storage and backup systems, and by selecting mixes of renewable energies which, in aggregate, tend to reduce the extremes of cyclic or erratic variability of individual options.

6.3 State of Technology

The state of technological development of a particular energy alternative is an important factor in selecting energy options. Conventional energy sources, in general, are technologically more mature than renewable options. This gives the former a "head start" in terms of the costs of producing or converting energy. Many renewable and conservation options would be feasible at the present price of oil and would be generally accepted if they had received higher priority for R&D in the past. The exploitation of such options should not be prejudiced by their relative newness. Great care is needed in making forecasts of potential that is implied from limited R&D programs. Overly optimistic forecasts become discredited and set back real progress, while pessimistic forecasts often become self-fulfilling prophecies.

6.4 Environmental Implications

Environmental concerns for specific alternatives have been summarized in Section 4. Several general points can be made about assessing the environmental implications of energy options.

First, environmental factors should be fully considered from the start in assessing energy options. The impact of the environment on an energy development can be a major determinant of technical and economic feasibility, particularly for frontier develop-

ments. Once feasibility is determined and the go ahead is given, environmental information will be required for project design. Lack of appropriate environmental data and understanding will thus impede development. In turn, the impacts of energy projects on the environment can be severe. It is generally more efficient in terms of dollar costs and timing to consider environmental implications from the start in order to ensure that provisions are made to meet regulatory and environmental assessment requirements, and to respond to public concerns.

Second, environmental impacts can lead to significant social and economic effects of other "users" of the environment (e.g. effects of acid precipitation on fish, related effects on tourism, on public health and on agriculture). Thus, the associated social and economic costs should be considered also.

Third, the environmental significance of the total fuel and materials production cycle should be considered when assessing environmental impacts. Environmental significance depends on scale (e.g. the wholesale production of photovoltaic cells or the widespread use of wood burning stoves in urban areas), on location (e.g. Arctic ecosystems, local habitat, downwind effects) and on the type of activity (e.g. dam construction, manufacturing of components, operation of aerogenerators). An alternative, which may be quite acceptable in environmental terms on a small scale or in certain locations, may be unacceptable for large scale operations or in more sensitive locations,

6.5 Economics

A general and popular concern for environmental quality is greatest in a period of economic well being. Environment Canada is concerned about the future of the Canadian economy and seeks to promote and facilitate its growth in environmentally appropriate ways. Canada's renewable resource potential, both energy and non-energy, has a central role to play in the future development of the nation. Thus, it makes good sense in both economic and environmental terms to emphasize renewable resources in Canadian energy strategies.

Economic criteria for selecting energy options should include effects on the balance of payments, security of energy supply, degree of protection against rapidly escalating energy prices, prospects for employment, and economic development both nationally and regionally. The use of (domestic) renewable resources improves the balance of payments and offers security of supply. Renewable such as hydropower, solar and wind offer a good cushion against rapid energy price increases, once the initial investment is made.

Renewable energy resources can also make important contributions to regional and local employment and economic development. Non-urban and less wealthy areas of Canada generally are faced with the most expensive energy bills today. Although the market for energy may be small-scale or "micro" in rural and northern areas, the contribution of these areas to the social and economic well-being of this large nation is critical. Renewable resources such as biomass, alternate hydro, wind and solar energy have a special appeal for such areas. Their exploitation for energy purposes could provide local energy price stability and other economic and social benefits. The use of renewable energy resources can also avoid the cost and inefficiency of long distance transport of energy, assure local security of supply and maintain more decentralized control over energy supply and pricing.

Capital costs and the life of the project or product are also important economic considerations in selecting energy options. Hydro power installations, solar panels and certain conservation measures are capital intensive but have substantial life cycles. In comparing energy options, returns across the total life cycle must be considered, along with capital cost requirements. Due to the tendency to discount future returns heavily, the market place often "biases" its decisions in favour of options with short pay back periods. Returns on investment which are realized in the latter part of the life cycle are usually not given much consideration. Government intervention in the form of incentives, subsidies or possibly regulations (e.g. building code changes) may be required to reduce such biases. Certain aspects of energy conservation, and passive solar building design, are examples of where such intervention is particularly important.

Energy developments frequently involve the use of resources for which there are competing demands. For instance land can be used to grow forests or to produce food crops. Forests can be used to produce lumber, pulp and paper, or methanol. Forests can also be left to play their role as parks and wildlife habitat or as a control element in the water cycle. These uses of land can also be traded for the production of hydropower and other amenities that can be obtained by damming rivers. Since some of these demands are mutually exclusive, their existence must be recognized in the course of energy planning.

6.6 Social Change

Energy is the major moving force in society. History shows the dramatic changes in social evolution that have occurred as society has moved through the wood burning, coal burning and oil burning eras. As society moves to more dependence on oil substitutes and eventually to an energy supply mix which (by

necessity) is largely renewable, some changes in life styles must be anticipated. The implications go far beyond just unplugging one option and plugging in another.

One basic factor to consider will be: to what extent does adoption of a particular energy option, or group of options, affect the degree of centralization or decentralization of our energy systems, and to what extent will control of such systems lie with individuals and the community as opposed to technicians and large institutions?

It is not possible to make policy decisions about energy, which must directly influence or interfere with the operation of the market place, without influencing the life-style options open to Canadians. Because energy decisions influence the evolution of Canadian society, the broader social implications should not be forgotten in selecting future energy paths. The paths selected should be compatible with the type of society Canadians want. A study sponsored by Environment Canada (1) indicates that Canadians would like to see a society evolve which is characterized by factors such as:

- diversity of lifestyles
- more emphasis on non-material values
- human-centred
- high value on the quality of relationships with others and with nature, and
- reduced dependency on large institutions.

6.7 Energy Supply Flexibility

Energy requirements are difficult to forecast with accuracy. Escalating energy prices, conservation programs, domestic and foreign political factors, and changing societal values each have an effect on future demand. Large scale energy projects with long planning and construction lead times could be particularly vulnerable to shifts in demand.

Renewable energy resources can provide considerable flexibility in responding to changing demand patterns across the country. In a relatively short time solar collectors can be installed, wind generators erected, and small scale hydropower developments completed. Thus, the chance of either supply shortages or excess supplies can be reduced through increased use of more flexible energy options. Short and long term "load following" ability is an important factor in ensuring overall efficiency in the energy supply system and minimizing the risk of energy crises.

6.8 Net Energy Analysis

Net energy analysis is useful in identifying the type and amount of energy inputs needed to produce a given energy output and thus indicates the true efficiency of the conversion process. An energy process or conversion device which requires a large oil energy input would obviously be less attractive in energy terms than one providing the same net energy yield from more plentiful energy sources. From an environmental point of view, high net energy yields produced from processes or devices which use environmentally benign energy inputs are the most attractive.

Energy analysis on a national scale can reveal the true picture of energy imports and exports. Energy is imported and exported both as energy itself, and indirectly in product form. Although Canada has a policy of restricting oil exports, much oil is exported indirectly through the sale of products such as paper, refined metals and chemicals which Canada manufactures with relatively cheap domestic oil. Given the current policy of subsidizing imported oil and maintaining the domestic price of oil below world prices, these exports are a drain on oil reserves as well as on public funds. This is not necessarily undesirable in aggregate economic terms but energy analysis can make explicit the degree to which this is occurring.

6.9 Assessing "Intangible" Factors

Some of the factors just discussed can be quantified for use in comparing the costs and benefits of specific energy options. However, many factors of equal importance as selection criteria do not lend themselves to meaningful quantification. Many social and environmental factors fall into this latter category. Environment Canada has made attempts to quantify environmental intangibles (2), (3). However, the results have not been particularly satisfactory. The costing of environmental impacts is severely complicated by the complexity of the environment and of our society. Some effects may take decades to work their way through ecological pathways and manifest themselves in an observable manner. Pollutants may interact synergistically among themselves and with elements in the ecosystem to produce new compounds whose biological impact may be greatly different from the impact of the original pollutant. In addition, relatively insignificant quantities of a material may accumulate biologically to levels that are toxic to both man and animals. Thus, even the most sophisticated approaches for costing environmental and other intangibles depend on subjective judgments.

Researchers of late have given less attention to the problems of assigning prices to unpriced goods. More attention is now being given to public participation as

a means for developing an appreciation for the value that society puts on less tangible factors.

The government has created the Environmental Assessment and Review Process to deal with projects on federal lands or funded by the federal government. This process involves public hearings for the purpose of discussing the predicted environmental impacts of specific projects. Through this process, some idea of the value that people put on the impacts can be gained,

In the United States, a number of "goals for the future" exercises, based on comprehensive public involvement and awareness programs, have been initiated with varying degrees of success. Over 36 cases have been documented at the regional, state and local levels. (4). These exercises are charac-

terized by their longer term view of the future (e.g. Atlanta 2000, Iowa 2000), and provide a long range direction for government economic planning, including the planning of energy supplies and use. Similar goals processes for Canada such as "Sudbury 2000" could contribute to a better definition of future energy needs and aid in the selection of energy supply mixes and energy paths that would be both energy efficient and socially acceptable.

A major study entitled "Global 2000" (1) has just been published in the U.S.A. This document authoritatively indicates current trends and the problems that these trends imply. A similar analysis using Canadian data has just been completed by the author of Global 2000 and the resulting publication is now available in the book-stores under the title "Global 2000: Implications for Canada".

7 Energy Research and Development

Most of the energy alternatives being considered by the Committee are at an early state of technological development and will require considerable R&D to ensure economic viability, efficiency in the conversion of energy, and appropriateness in social and environmental terms. For those energy options likely to have application in Canada, the question arises: should Canada develop its own technology, or should it import the technology when it becomes available elsewhere?

Public funds available for R&D are finite. Spending on one option deprives other options of the chance to "prove themselves". Yet, funding every option would spread the R&D effort too thinly. Explicit R&D funding criteria are needed in order to focus efforts on areas where the returns are highest in terms of economic development, energy substitution, resource sustainability, and environmental appropriateness.

Environment Canada advocates a focused R&D thrust, defined largely on economic grounds. The size of the potential domestic market for many energy technologies is small relative to other countries, and Canadian R&D resources are limited. It makes good economic, and eventually environmental, sense to concentrate Canadian R&D on those technologies which are most appropriate for Canada's specific needs and whose development can foster expansion into international markets. The market for exports, both of products and expertise (consulting, etc.) should be considered. Alternative energy technologies that are appropriate for Canada may also have particular application potential in many Third World nations as well as in other industrialized states.

We suggest the primary criteria for allocating resources to R&D in the energy field should be related to:

1. the development of technologies for energy resources of which Canada has a relatively large share in global terms, and where a reasonable comparative advantage is assured, and
2. the development of specific applications of energy technologies to meet Canadian needs in a Canadian context (geography, climate, population distribution, etc.)

Based on these criteria, the following alternative energy resources and technologies appear particularly applicable (not in order of priority) as a focus for Canadian energy R&D:

- forest biomass for direct combustion and for the production of liquid fuels;
- alternate hydropower;
- active and passive solar energy, including climatically appropriate building design, in northern climates (central and northern Canada);
- wind generation for isolated communities;
- transmission and transportation of energy over long distances;
- tidal power;
- energy storage — both short term and seasonal — for electric power and space heating uses;
- substitution of communication for long distance transportation (Canada has a large "share" of long distances).

The above R&D areas do not coincide in every case with energy options to which Canada should give priority. For example, solar panels in southern Canada and energy efficient technologies such as co-generation are important in Canada's energy future, but it would be difficult to rationalize an in-depth national research effort, given the state and scale of R&D efforts taking place on these topics in other countries.

For areas which do not fit the above criteria but which have potential application in Canada, it may be appropriate to mount a minimal effort to ensure effective technology transfer from external sources and application to the Canadian context. An appropriate mechanism may be through international cooperation. This mechanism could be very appropriate for developing, for example, fusion power and more environmentally appropriate coal conversion and combustion technologies.

8 Developing A Strategy for Canada's Energy Future

The foregoing leads to the following conclusion: A substantially increased role for renewable energy resources and a more concerted emphasis on energy conservation is both practical and desirable on economic, environmental and resource grounds. Thus, Environment Canada advocates a sustainable energy future for Canada: one which gives high priority to energy conservation and relies much more than at present on renewable energy resources. This energy future would be compatible with a future Canada in harmony with the environment, tapping natural flows to meet its energy needs. However, this would require managing and wisely using water, trees, land and air resources to ensure sustainability — sustainability in the sense that the potential of these resources would be assured in perpetuity for meeting the needs of future generations. The message of the "Global 2000" report to the President of the United States (1) underlines the urgency of giving serious consideration to taking steps now toward the evolution of a sustainable future.

Increased reliance on renewable forms of energy will not mean a return to the past. A society which relies substantially on renewable forms of energy need not be very different from today's society. We can be just as mobile on energy-efficient vehicles powered by methanol fuels as we are today, Homes and buildings can be just as comfortable if designed according to environmental criteria and heated by solar radiation, Products can give just as much material satisfaction if made from recycled materials produced by efficient industrial processes, Research leading to intermediate and high technology developments will be an important factor in realizing the full benefits of Canada's renewable resource base,

Furthermore, industry will have technological opportunities associated with new areas such as: intensive renewable resource management, renewable energy technologies, biotechnology, the development of efficient (in energy and materials usage terms) industrial processes, materials reuse and recycling, energy conserving buildings and transportation systems, communications systems which obviate the need to travel or commute long distances, and more refined environmental (including climatic) forecasting.

An energy strategy based on renewable energy resources and energy conservation should provide a framework for long-term energy planning at the national level. However, the strategy must also be implemented through energy planning at the regional and local level. This is true, in particular, where energy sources are available within the region in which they are used. Certain energy conservation programs can be most effective if locally planned and implemented, Decentralized energy planning also can more effectively take into account regional and local environmental limitations and capabilities relevant to energy developments.

The argument for emphasizing conservation and renewable energy as central components in an energy strategy has been made in other countries on grounds broader than environmental factors. For example, the Report of the Harvard Energy Project (2) argues that consumers should be encouraged toward conservation and renewable energy "not because there is anything virtuous about these energy sources, but *because they make good economic sense*". The central conclusion of the report is that, for the United States at least, these two alternatives are much to be preferred over oil, gas, coal and nuclear sources and that they, therefore, should be given a chance to compete on an equal footing with other options. The Harvard analysis found that conservation, with the aid of renewable energy could, with appropriate measures, provide two-thirds of the "increased" U.S. energy needs for the later 1980s.

Renewable resources and conservation will ease the burden but they cannot provide the complete answer to Canada's energy future, To ensure the most effective application of renewable energy resources, the focus should be on meeting new, rather than existing, energy needs in the residential, transportation and industrial sectors. By substantially increasing the role of renewable resources and conservation, fossil fuel and nuclear fission energy would be left to perform those tasks for which they are uniquely suited, and at levels of development where the environmental effects are reasonably manageable. The energy statement just released by the Canadian government recognizes the importance of

renewable forms of energy and conservation. ("The National Energy Program", 1980, EMR)

In selecting from among the various alternative energy resources and technologies a wide range of factors must be considered. Social and environmental factors, resource availability and sustainability, and net energy should be given full consideration from the start. Decisions must take into account less tangible but equally real factors. R&D efforts must be selective and focused on the most appropriate areas for technological development which will give the greatest economic returns.

An energy strategy for Canada which centres on conservation and renewable resources would have many barriers to overcome. These barriers stem from our present dependence on increasingly scarce fossil fuels, and from the widespread institutionalization of practices which waste energy. However, with definite goals in mind, and a corresponding long term energy strategy, these barriers can be overcome without significant adverse effects on the social and economic well-being of Canadians.



References

Section 2

1. McKay, G.A. and Allsopp, T. R., "The Role of Climate in Affecting Energy Demand/Supply", Canadian Climate Centre, Atmospheric Environment Service, Downsview, 1980,

Section 5

1. Robinson, D. L., "Energy Conservation and Environmental Management: A Synergistic Partnership toward a Sustainable Society", Environment Canada (unpublished paper) October 1977.
2. Sewell, Derrick W.R. and Foster, Harold D., "Analysis of the United States Experience in Modifying Land Use to Conserve Energy", Lands Directorate, Environment Canada, March 1980, Working Paper No. 2.
3. Sewell, Derrick W.R. and Foster, Harold D., "Energy Conservation through Land Use Planning: A Synthesis of Discussions at a Symposium held in Montreal 26-28 March 1980", Lands Directorate, Environment Canada, August 1980, Working Paper No. 6.
4. McKay, G. A., "Climate and Energy Conservation", Conference on Climate and Energy: Climatological Aspects and Industrial Operations, May 8-12, 1978, Asheville, N.C. Published by American Meteorological Society.

Section 6

1. Starrs, Cathy, "Canadians in Conversation about the Future", Environment Canada (Office of the Science Advisor Report No. 12), 1976.
2. Maniate, Peter C. and Carter, Donald C., "The Evaluation of Intangibles in Cost-Benefit Analysis: A General Method", Policy Branch, Environment Canada, December 1973.
3. Coomber, N.H. and Biswas, A.K., "Evacuation of Environments/Intangibles" Geneva Press, N. Y., 1973.
4. Bezold, Clement (Editor), "Anticipatory Democracy: People in the Politics of the Future", Vintage Books, 1978.

Section 8

1. United States Council on Environmental Quality, "The Global 2000 Report to the President of the U. S.; Entering the 27th Century", Washington D.C., U.S. Government Printing Office, 1980, 3 Volumes.
2. Stobaugh, Robert and Yergin, Daniel (editors), "Energy Future: Report of the Energy Project at the Harvard Business School", Random House 1979,

APPENDIX A

ALTERNATIVE ENERGY RESOURCES

Appendix A: Alternative Energy Resources	31
A-0 Introduction	33
A-1 Solar Radiation	34
A-2 Wind	37
A-3 Alternate Hydro	40
A-4 Tidal Power	42
A-5 Wave Energy"	44
A-6 Thermal and Salinity Gradients	45
A-7 Biomass	46
A-8 Municipal Solid Wastes	51
A-9 Geothermal Energy	53
A-10 Peat	55
References to Appendix A	59

A-O Introduction

This Section discusses a number of alternative energy resources which have potential for meeting Canada's future energy needs. The potential of each of the resources is described briefly, together with a short description of the technology associated with the resource. The major environmental implications are then outlined to take account of both direct and indirect impacts. Indirect impacts include those associated with the production of materials (i.e. the "materials cycle") for the manufacture of components

or for the construction of physical structures. Often these impacts are relatively insignificant when compared to the direct impacts of producing energy from the resource but in the case of, for example, solar panel farms or hydropower structures they can be significant. In addition, in the case of resources such as biomass and peat which have a "fuel cycle", the environmental implications of the total fuel cycle, from harvesting or extraction through to conversion and fuel waste disposal are considered, where significant.

A-1 Solar Radiation

a) Resource Potential

Despite its northern location, Canada possesses an abundant supply of solar energy. The annual amount of solar radiation received is approximately 6000 times the annual Canadian consumption of all forms of energy. Figure A. 1 shows that the southern sections of Canada up to the latitude of 55° N, which are also the most populated, have the highest potential for solar energy utilization. Useful application of solar energy also may be possible in the far northern sections of the country during the long period of daylight experienced in the spring and summer months. The distribution of solar energy can partially offset the less convenient geographical location of some other sources of energy relative to their major Canadian markets. Canadian energy sources with potential are located in more northern areas (e.g. hydropower, oil and gas) or in the east or west (coal, hydropower), hence requiring long distance energy transmission and transportation systems.

The development of solar energy has a number of constraints. The diffuseness of the resource necessitates large capture areas for industrial or utility exploitation. For example, a 1000 Mw solar electric power plant could require a collector area equivalent to a square with sides 8 km long. Also, the solar radiation received fluctuates greatly between summer and winter. For cities, even in southern parts of the country, the worst winter month may receive only one-sixth of the solar radiation of the best summer month. Thus, the seasonal fluctuation of solar radiation received is completely out of phase with the demand cycle for space heat.

It is clear that, for Canada at least, the key to fully harnessing this vast natural flow of energy is efficient storage — storage to bridge seasonal gaps and to overcome the handicap of its diffuse nature.

Close to one-third of energy consumed in Canada is used for low temperature heat needs such as domestic and industrial space heating, and domestic hot water. Solar energy, with storage for backup, is particularly suited to meet geographically dispersed, low quality heat requirements of this nature. Already,

solar radiation, through passive solar gain, is providing about 12% of Canadian residential space heating needs (1) without any conscious exploitation.

One recent study reports that direct solar energy could provide from 3 to 8% of total U.S. energy consumption (assuming this to be 100 quads) by the year 2000 (2). Although such estimates are rarely voiced for Canada* it is interesting to note that solar radiation received over the most heavily populated part of the U.S. (eastern U. S.) is within 25% of the solar radiation received over the southern part of Canada where demand for space heating is also concentrated. This comparison is based on the amount of solar radiation received on a horizontal surface. In addition, latitudinal effects have only a secondary influence on solar energy received on a flat surface *inclined* from the horizontal at an angle approximately equal to the local latitude. (Regional climatic conditions are the primary influencing factor.) Ignoring the effect of climate, an inclined solar collector located in Winnipeg can receive, over a one year period, about the same radiation as an inclined collector in Florida (3). However, the effect of latitude on solar radiation received increases rapidly as one moves northward from Winnipeg into the northern Territories. Thus, the potential contribution of solar energy for Canada is not substantially different from that available for the U.S.

Longer term records (more than 30 years) of solar radiation exist for only a few major Canadian centres. There are now over 100 locations in Canada for which at least 10 years of data exist. Although these data are based on radiation hitting a horizontal surface, steps have been taken to derive data for various inclined surfaces and with various azimuths for most of these locations (4). Radiation data compiled on this

* We note that the presentation by NRC to the Committee on July 9, 1980 suggested the following approximate solar energy potentials could eventually be realized under appropriate conditions (percentages based on total national energy consumption): passive solar — an additional 2% by the year 2000; domestic hot water — potential impact 1 1/20/0; industrial process heat — potential impact up to 10%; space heating (active solar) — potential impact 2%

**ANNUAL MEAN DAILY SOLAR RADIATION
(MEGAJOULES PER SQUARE METRE)**

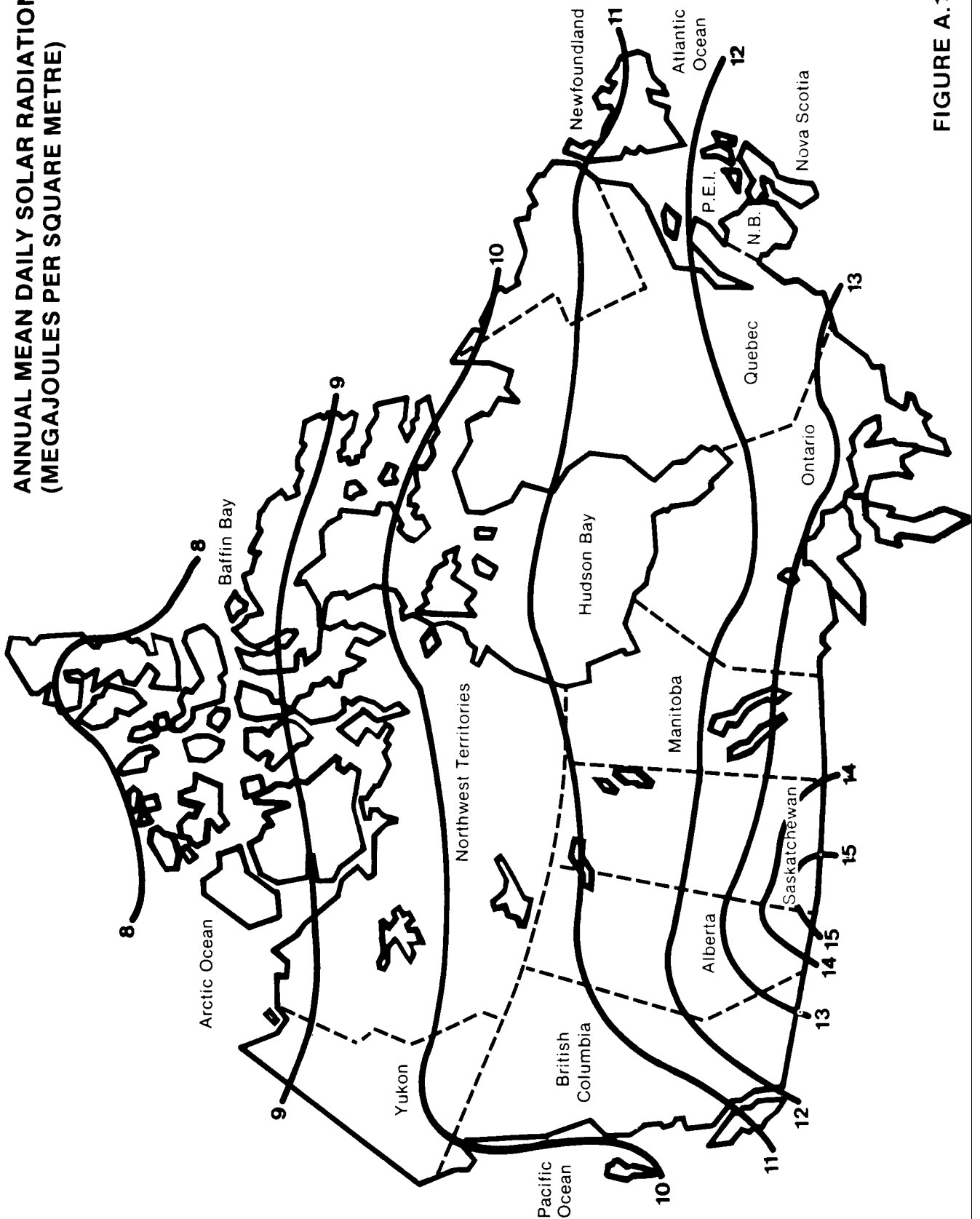

FIGURE A.1

basis will facilitate the effective design of both passive and active solar energy systems for any geographic and climatic situation across the country.

In response to the need for more appropriate solar energy data, Environment Canada is developing existing and new solar radiation data files, and is conducting solar spectrum and site specific solar studies. This program will lead to a more accurate picture of the solar energy potential in various locations across the country. It will also provide design parameters essential for solar technology and applications design.

Clearly, Canadian climatic and energy demand characteristics pose major problems. However, the most significant problem, at least initially, is one of attitude. Improved understanding of a relatively unique Canadian situation vis-à-vis this somewhat novel but potentially large energy source will do much to bridge this attitudinal gap.

b) Technology

Technology is the key to solar energy transformation and application, at an acceptable price. The Canadian energy demand and solar radiation patterns, and the country's extremes of climate and geography, are sufficiently unique that total reliance on foreign technological transplants would significantly retard the development of this potential. Particular R&D emphasis should be given to solar energy storage, both short and long term, and to energy back-up systems, as well as to climatically appropriate building design which taps the full potential of passive solar heating and reduces extremes in space heating demands. Through appropriate incentives in these areas, Canadian industry could build a significant comparative advantage in a very promising growth industry,

c) Environmental Implications

The use of solar energy reduces the demand for fossil fuels and, hence, leads to the conservation of such non-renewable energy sources and to the reduction of their accompanying negative effects.

Environmental impacts vary substantially among the various solar options. These impacts fall into two categories (5): (i) land use requirements, which could compete with other uses of land, especially near urban areas and (ii) emissions associated with the mining and production of the materials required to manufacture solar equipment.

The passive solar energy option is the most benign from an environmental point of view since special materials requirements or land use implications are relatively minor, if significant at all.

Community-based (decentralized) solar collection could affect land use patterns. Proper orientation of

buildings for solar energy purposes could increase the cost of houses in the community. For example, services for providing utilities might have to cover greater distances, or the land developer might not be able to achieve maximum utilization of his land (fewer lots per acre). Utilization of solar energy could also influence residential and commercial architectural styles and require changes in building codes. Multi-unit structures would present fewer problems of this nature. Solar space heating using seasonal hot water storage appears economically feasible for such structures at the present time.

Land use requirements for a large scale solar thermal or photovoltaic generation plant would be substantial, and likely to be prohibitive close to urban areas. However, the spatial requirements are probably comparable to those required by conventional fuel options when their total fuel cycle requirements for extraction (e.g. surface coal mining), processing, transportation, combustion or conversion plant and waste disposal, over an equivalent life cycle period are considered. In addition, the solar energy option would, in most cases, be less disruptive to land use and could offer some opportunity for multiple use of the land (e.g. underground developments).

The environmental impacts resulting from the production of materials for solar equipment on a large scale could be substantial when cumulated. While the additional impacts arising from producing, for example, copper for solar panels may be a small portion of the total impacts associated with the copper industry, they are significant when compared to impacts arising from conventional heating systems. For example, the production of copper, aluminum and steel for a solar heating system would emit much more particulate and sulphur oxides that would the *annual operation* of a domestic oil or gas heating system with equivalent energy output, and somewhat more than the annual emissions produced by a coal-fired generating station in providing the same energy output for electric space heating (6),

However, it is important to note that the solar heating system causes pollution only during the mining, processing and production phases of the material for the equipment, but not during its operating life. In comparison, the operation of a conventional system produces pollution not just at the combustion or conversion stage but throughout its fuel cycle, and on a continuous basis throughout its life cycle. In addition, recycling of materials after the useful life cycle would be much more feasible for solar equipment than for conventional plants. Material recycling would substantially reduce energy input requirements and pollution for succeeding life cycles.

As with other power generation options, centralized solar thermal power generation would require water and would produce waste heat. This problem does not occur in the case of solar photovoltaic plants.

A-2 Wind

a) Resource Potential and Technology

It is convenient to consider wind generation of electrical power in three categories:

- 1) Small and medium Wind Energy Conversion Systems (WECS) of rated power 1-100 kw for individual households or farms and small isolated communities;
- 2) Large WECS (1-10 Mw) placed singly or in small clusters:
- 3) Wind farms of 10-100 WECS, total installed capacity typically 100 Mw, probably on land, but possibly offshore.

Small and medium WECS could make a contribution to national energy requirements provided agreements could be reached between electricity supply agencies and machine owners. The U.S. Dept. of Energy anticipates approximately 10% of their wind power coming from such machines by 2000. Many areas of Canada would be suitable for installation of such machines if the economics relative to other energy supply options were favorable (say approximately 5 cents/kwh for a 6 metres/second annual average windspeed at hub height). If a substantial contribution to national energy requirements is to come from wind power, however, it will most likely be based on clusters and farms of large WECS. The limitations to wind power will be primarily those imposed by economics, and in particular, the economics of integrating a variable wind power component into a fixed electrical power network.

Although the total wind power potential in Canada is very large, it is highly variable across the country (see figure A.2). The annual amount of wind energy potential available has been estimated, optimistically, as 60,000 Mwh (1), which is close to the current total installed electric power generation capacity in Canada (77,600 Mw in 1979). Preliminary surveys suggest the Atlantic Seaboard including the Gulf of St. Lawrence, the region around Hudson Bay, and SW Alberta as areas of high wind energy potential. Coastal sites (including coastal hills) are most suitable for single

machines or small clusters, while large wind farms may be viable in southern Alberta and Saskatchewan, and even in the Great Lakes region.

The Department is currently conducting more detailed national and regional wind resource mapping, and is developing techniques for the evaluation of specific turbine sites. We anticipate no difficulty in finding meteorologically suitable sites for the 3200 Mw of wind power that NRC suggests could be installed by the year 2000 (2).

b) Environmental Implications

Wind energy is generally considered to be environmentally benign as a source of electric power. There are neither water requirements nor direct air, land, water or thermal pollution impacts.

For a large scale centralized wind power development, however, land requirements would be substantial. Nevertheless, they would be comparable to more conventional power generation options if the total fuel cycle land requirements of these options were considered. Furthermore, wind turbine arrays lend themselves to multiple use opportunities such as agriculture, which would effectively reduce the land requirements. Also, since Canada's areas of high wind potential are generally removed from high population densities, the chance of land use conflict at the generation site would be reduced. But the accompanying transmission corridors over long distances would have to be considered (as with transmission from large scale hydro power developments, or gas or oil pipelines from frontier locations).

The visual impact of large numbers of large wind turbines (with typical heights of up to 150m) on coastal hill sites could be substantial. (One is attractive, one hundred are an eyesore!). The British Central Electricity Generating Board regard this as a major obstacle to siting wind turbines along the west coast of the United Kingdom, but the eastern seaboard of Canada is longer and not so heavily used for recreational purposes. Both visual and land use concerns could be mitigated through locating wind farms well off-shore.

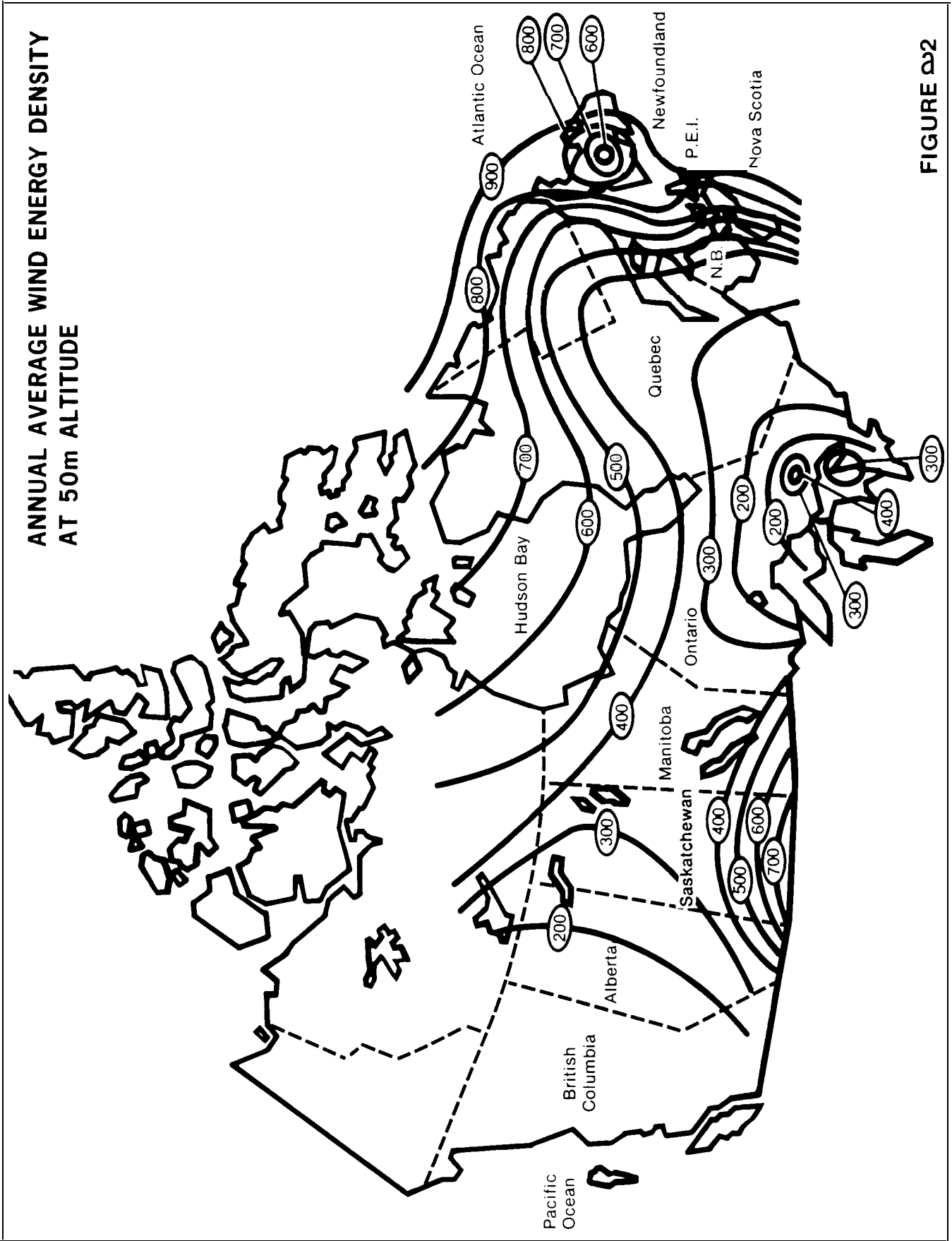

FIGURE 2

Local interference to TV reception and some noise problems (infrasound) have been caused by two of the American Department of Energy turbines. The television interference is very local (1-2 km area around the turbine) as are most of the noise problems. Cattle graze contentedly near the base of the 630 kw wind turbines at Nibe, Denmark, where one hears only a gentle "swish, swish" within a few hundred metres of the machine.

Bird strikes are a potential ecological impact, primarily in relation to night migration, but studies in Batelle-Columbus, Ohio, suggest that most birds and insects will avoid the turbine. However, the hazard is likely to increase with increases in height and clustering of turbines. Installation on known key migration corridors of birds and insects should be avoided.

Ice, or even blade shedding is a hazard which needs to be considered in the safety aspects of turbine operation.

The environmental impacts of producing material requirements for a large scale wind energy program could be substantial, but not likely as great as for an equivalent solar program. Materials impacts also would be much less than impacts associated with more conventional power generation options when the pollution from their total operational life cycle is considered. Wind components, as with solar, should lend themselves to recycling which would further reduce the material impacts.

A-3 Alternate Hydro

a) Resource Potential

The potential of alternate hydro sites such as small-scale, low-head or micro sites, abandoned power sites or existing non-power dams has been overlooked due mainly to the cost advantages that thermal power alternatives once had.

Small-scale hydro developments are normally defined as those sites with a capacity range of from 50kw to 15,000kw. A small-scale hydro site could have very high-head or very low-head. Low-head sites are normally defined as those sites with a head of up to 15 metres but without flow capacity limitations. These formerly uneconomical and overlooked hydro resources have become viable due to recent rises in fuel costs and improvements in technological efficiency.

Alternate hydro-electric development has many advantages. It tends to be relatively cheap, is renewable, is available across the country, offers good long term protection against inflation, and uses a technology with which Canadians have expertise. It has the potential to meet, at least in part, the electricity requirements of many non-urban populations located, for example, in northern communities and small towns scattered across the country. It would be partially attractive for communities currently dependent on diesel units. Electricity produced through alternate hydro may also be sold to major electrical companies to be added to the power grid.

To date, federal involvement in hydro electricity production has generally focussed on large developments. Various other countries, including the United States, have directed part of their attention to the possibility of alternate hydro development. In Canada, there is no policy or program directed to this end as yet.

The country's undeveloped hydropower potential, mostly large scale and alternate hydro, is estimated to represent approximately 2.5 times the existing hydro power capacity (Table A. 1). The nation's potential alternate hydro is presently unknown and needs to be assessed through a national inventory program.

For example, one source has suggested a potential of small-scale hydro in Canada as large as 67,000Mw or about 1.5 times the present hydropower capacity. This seems to be over-estimated. If the potential were only one-half of the present hydropower capacity or 20,000 Mw, it would save about 180 million barrels of oil per year assuming it replaced the energy generated by oil-fired power plants.

Part of the difficulty in taking advantage of the opportunity for alternate hydro appears to be attitudinal. The large electric utilities, for the most part provincially owned, see their role as delivering power to the entire province in a way that incurs the lowest possible costs to them. This has meant concentration on large scale projects and transmission schemes. Thus there may be room for a federal initiative to assist in demonstration projects. This assistance could be directed to both large and small utilities as well as to municipalities, conservation authorities or small firms.

Limited steps in this direction are being taken by Department of Energy, Mines and Resources. It is providing 90% of a \$1.2 million hydro-electric plant to replace a diesel unit at Roddickton, Newfoundland and is sponsoring a survey of micro and mini-power sites in British Columbia. Ontario Hydro is installing a new unit in an abandoned plant in the Georgian Bay area to service a remote community of 150 persons. The National Research Council has requested proposals for the study of devices to extract energy from river and tidal flows.

b) Technology

No new technology, in the sense of a technical breakthrough, has been developed in hydro-electric energy conversion techniques during the last half century. Some noticeable technological changes, however, have been taking place such as: upgraded efficiencies of old equipment; development of new "off-the-shelf" small units suitable for small scale hydro sites, low-head horizontal shaft and bulb turbines; and the use of new operational and control techniques (e.g. remote and micro processor controls, integration of pumped-storage, transmission inter-typing and system optimization).

TABLE A.1
HYDRO ELECTRIC POWER IN CANADA
EXISTING CAPACITY AND UNDERDEVELOPED POTENTIAL
(1 000MW)

PROVINCE OR TERRITORY	EXISTING ELECTRIC POWER CAPACITY (1 979) TOTAL "	HYDRO POWER COMPONENT	ESTIMATED UNDEVELOPED HYDRO POWER POTENTIAL
Newfoundland	7.1	6.5	6.4
P.E.I.	0.1		
Nova Scotia	1.8	0.4	0.1
New Brunswick	3.4	0.9	0.8
Quebec	18.2	16.8	31.6
Ontario	25.7	7.1	6.2
Manitoba	4.1	3.6	4.6
Saskatchewan	2.1	0.6	1.2
Alberta	5.4	0.7	17.2
British Columbia	9.5	7.6	30.1
Yukon & N.W.T.	0.2	0.1	12.0
Totals for Canada	77.6	44.3	110.2

' Total existing capacity includes hydro, fossil and nuclear sources.

Source:
 derived from *Electric Power in Canada for 1979, E.M.R.*, and data submitted to the World Energy Conference, 1979.

c) Environmental Implications

Environmental impacts from carefully designed alternate hydro development would be minimal and should lend themselves to advance remedial measures. With low-head developments, for example, there would be less flooding due to impoundments and less reservoir fluctuation as compared to large developments. Although fish mortality would presumably be comparable to conventional hydro,

methods of incorporating fishways are available. As well, competition for water to be used in different and potentially conflicting ways would require resolution. On the positive side, the impoundments could create new habitat for waterfowl, as well as opportunities for recreation. The effects on land use would be minimal in comparison with those associated with conventional hydro development. Nevertheless, land use effects would occur and would require consideration in the planning and design of alternate hydro generation sites.

A-4 Tidal Power

a) Resource Potential

Figure A.3 shows those locations around the globe which offer potential for tidal power. For Canada, there are 3 locations: The Bay of Fundy, Ungava Bay and the B.C. coast.

Changes in energy economics have increased Canadian interest in the potential of tidal power, particularly in the Bay of Fundy. The latest reassessment study conclusively demonstrates the fundamental economic feasibility of developing the energy of the Fundy tides, and the technical and economical feasibility of its integration into the projected generation supply systems of the Maritimes Provinces. The economic tidal potential of the Bay of Fundy is estimated to be 16×10^6 Mwh. (1) However, development of tidal power in Ungava Bay and on the British Columbia coast are not considered feasible because they are either too distant from major load centres or too expensive relative to other generations options available for the foreseeable future.

b) Technology

During the past two to three decades there have been a number of technological innovations in turbo-generating units, in marine construction and in the mathematical understanding of tidal cycle variations. It is now clear that major technological problems formerly associated with large-scale tidal power developments have been resolved. Canadian development in this area will provide good oppor-

tunities for the export of both Canadian expertise and equipment to assist in the exploitation of this resource on a global basis.

c) Environmental Implications

The exploitation of tidal energy, given the nature and scale of the work involved, will necessarily give rise to social and environmental impacts requiring appraisal on a broad scale. Although tidal energy may be pollution free in that it does not add pollutants either to the atmosphere or to the water, it will cause ecological changes in its tidal basin and, to some degree, may also affect the tidal regime on the sea side of the development. For instance, the changes in suspended sediment patterns from the existing regime may affect marine organisms. Changes may also occur in the system of currents, for example around the southwest coast of Nova Scotia. There could be changes in upwelling of cold water from the bottom which would, in turn, affect nutrients in the water and thereby affect fish stocks. The extent of this effect would, of course, depend on the magnitude of the tidal development. Some of the detrimental effects on ecosystems attributable to river hydro plants would be applicable also to tidal power plants. The location of important habitat for seabirds and for fish species would have to be considered before the choice for the site were decided,

Details of the potential of tidal power for Canada were provided to the Parliamentary Committee by Mr. R.H. Clark of this Department in July of this year (1980),

LOCATION OF POTENTIAL TIDAL POWER SITES



Source: R.H. Clark, Inland Waters Directorate,
Environment Canada,
"PROSPECTS FOR TIDAL POWER",
Conference on Long-term Energy Resources
(UNITAR),
October 31, 1979.

FIGURE A.3

A-5 Wave Energy

There is only a limited commercial potential in Canada for wave energy. However, the Department may undertake testing of a private wave generator in the near future.

The environmental impact of wave energy is expected to be minimal but no research has been done on it. Shore based installations which, for

example, convert electricity to hydrogen could have some impact. Nearshore wave action, or suppression of it, could change mixing and water temperature thereby affecting habitat for wildlife. Also environmental impacts could be produced by shore-based installations directly converting wave action into electricity.

A-6 Thermal and Salinity Gradients

Ocean thermal energy conversion (OTEC) requires the existence of a large temperature difference between near surface and deeper waters. In Canada, where the vertical temperature gradients of lakes and coastal waters is generally less than 10°C, the development of OTEC is not practical with present technology. Currently, no power-producing OTEC plants exist which could provide data under actual conditions of the environmental effects of harnessing this potential. Predictions indicate that the impact of individual plants will be modest. (1) However, the environmental effects of large-scale operations could be significant. Potentially significant effects may arise from the very great flows of water required and include releases of toxic chemicals during accidents, some entrainment of marine organisms in the heat exchangers, **upwelling** of deep nutrient rich ocean water, and releases of substantial amounts of carbon dioxide to the atmosphere.

The application of salinity gradients for energy conversion is currently not considered to have commercial potential in Canada although technological advances by the year 2050 could allow large scale, commercially viable development. Environmental impacts would be serious since sources of power from salinity gradients would be concentrated in the mouths of such large rivers such as the St. Lawrence, the Fraser and the Mackenzie. The effects on estuary ecosystems could be severe. Also, fresh water requirements for the power plant to provide the necessary salinity gradient would be substantial.

Both OTEC and salinity gradients were covered in the presentation made by NRC to the Special Committee on Alternate Energy and Oil Substitution in July of this year (1980).

A-7 Biomass

a) Resource Potential

A recent study has shown that Canadian forest biomass potential for energy purposes is substantial (1). Table A.2 gives the estimated potential that would be available on an annual basis for the years 1985, 2005 and 2025 at price levels of \$33 and \$44 per oven dried tonne (ODt) for the biomass. The estimates are based on potential supply sources from conventional forestry operations (mill and logging residues), biomass harvests from surplus natural stands and biomass harvests from managed plantations. The latter source is expected to make significant contributions only by the 1990's. The supply estimates take into account the alternate uses for forest materials such as for lumber, pulp and paper, and thermal energy uses within the forestry industry. Although the estimates were prepared on the basis of biomass potential for liquid fuel production (mainly methanol from forest biomass), they represent the total forest biomass potential that would be available for energy purposes in general, at the given price levels.

In order to provide some idea of the demand for biomass at those price levels for a particular end use, Table A.2 also incorporates projected methanol demand volumes and associated petroleum volume displacement, by end uses, for Canada and the provinces as well as the National Energy Board forecasts of Canadian consumption of crude oil. For example, if in Canada in 2005 the delivered price of biomass were \$44/ODt (\$1977), then the methanol available from the biomass would be 81,5 million cubic metres. This would more than meet the potential methanol demand of 76 million cubic metres and would mean a displacement of more than half of the forecasted Canadian consumption of crude oil (83.6 x 10⁶ m³ forecasted crude oil consumption and 48.1 x 10⁶ m³ crude oil displacement)*. Of course, methanol is only one of a number of energy end use forms to which biomass can be converted.

Energy plantations would require substantial areas of land in which, for instance, fast-growing hybrid poplar would be grown and managed using advanced agricultural technology. Such a concept could be applied in southeastern Ontario where, for example,

much of Class 3 and Class 4 agricultural land is currently not economically viable in food production. (2) However, if forecasts of a future food crisis materialize, presently sub-marginal agricultural lands may again find their higher value in food crop production rather than in energy plantations.

Compared with other solar energy collection techniques, an energy plantation requires relatively little commitment of physical materials. However, resource management practices to minimize environmental hazards such as the spread of disease and to develop guidelines on management practices such as strip cutting will be required to reduce the impact of environmental factors on biomass. There would also be a significant requirement for land and water that could conflict with foodstuff production. Although lands considered marginal for conventional agriculture might be selected for energy plantations, hilly terrain or low productivity of the soil would compromise the energy efficiency of the plantation.

Another source of biomass of interest to Environment Canada is aquatic weeds. Although the energy potential of aquatic weeds on a national scale would be slight, it could be attractive as part of a weed control operation. since control is currently hampered by a lack of use for such vegetation.

Municipal solid wastes also have significant biomass energy potential (see section A-8) as do agricultural crops and agricultural wastes (not covered in this submission). Shell Canada plans to start production of ethanol from corn by 1982 in a \$300 million complex located north of Lake Ontario,

* It is important to emphasize that the demand figures contained in Table A 2 are for projected methanol demand, *not* projected methanol consumption. Clearly, methanol will not become a major alternate liquid fuel, in terms of consumption, unless it is able to penetrate the total transport market — at least, not unless export markets emerge. To become a major domestic alternate liquid fuel, it must gain acceptance not as a blend component but as a complete fuel replacement for diesel fuel and gasoline in automobiles, trucks and buses. In Canada, this acceptance is not currently achievable because methanol absorbs water which freezes in winter. However 100/o solutions of methanol in gasoline are feasible.

TABLE A.2
ESTIMATED FOREST BIOMASS SUPPLY POTENTIAL AND PROJECTED METHANOL
DEMAND: CANADA, BY REGION, 1985, 2005, 2025

Potential Biomass Supply & Methanol Equivalent							
	Biomass Del. price \$33/t (1977) 10 ⁶ ODt	Methanol 10 ⁶ m ³	Biomass Del. price \$44/t (1977) 10 ⁶ ODt	Methanol 10 ⁶ m ³	Potential/ Methanol Demand 10 ⁶ m ³	Associated Crude Oil/ Displacement 10 ⁶ m ³	Forecasted Total Canadian Consumption of Crude Oil ^{3/} (NEB) 10 ⁶ m ³
1985							
British Columbia	17.6	9.7	29.2	16.1	1.5		
Alberta	7.7	4.2	11.6	6.4	1.5		
Man./Sask.	4.3	2.4	7.1	3.9	1.3		
Ontario	8.7	4.8	18.8	10.3	4.7		
Quebec	8.0	4.4	16.4	9.0	3.5		
Atlantic	6.5	3.6	9.7	5.3	1.4		
Total	52.8	29.0	92.8	51.0	13.9	9.2	69.1
2005							
British Columbia	17.1	9.4	35.6	19.6	7.6		
Alberta	13.1	7.2	23.2	12.8	6.9		
Man./Sask.	9.3	5.1	14.9	8.2	6.4		
Ontario	11.2	6.2	28.1	15.5	24.4		
Quebec	8.4	4.6	29.6	16.3	20.8		
Atlantic	10.6	5.8	16.8	9.2	9.8		
Total	69.9	38.4	148.1	81.5	76.0	48.1	83.6
2025							
British Columbia	19.4	10.7	36.1	19.9	9.6		
Alberta	12.2	6.7	20.1	11.1	8.0		
Man./Sask.	8.4	4.6	12.5	6.9	7.7		
Ontario	10.3	5.7	25.6	14.1	29.3		
Quebec	4.5	2.5	23.7	13.0	27.7		
Atlantic	9.3	5.1	15.1	8.3	13.6		
Total	64.1	35.3	133.1	73.2	95.9	60.5	

Note:
Totals may not add due to rounding. The figures are annually based throughout.

1/ The projected methanol demand volumes and associated petroleum volume displacement, by end uses, are based on projected world crude oil prices in 1977 Canadian dollars: \$25/bbl in 1985, \$30/bbl in 1990, \$35/bbl in 2000, and \$40/bbl in 2010 and thereafter.

2/ Crude oil is defined as the sum of gasoline, diesel fuel and middle distillates plus five percent for refinery losses.

3/ The sum of motor gasoline, middle distillates and diesel fuel oil.

Source:
This table is derived from Tables provided by *InterGroup Consulting Economists Limited*, May 1978 and the National Energy Board oil report, September 1978. The figures are not intended to be scientifically accurate but are indicative of supply potential and projected demand,

BIOMASS PRODUCTIVITY — ZONES IN CANADA

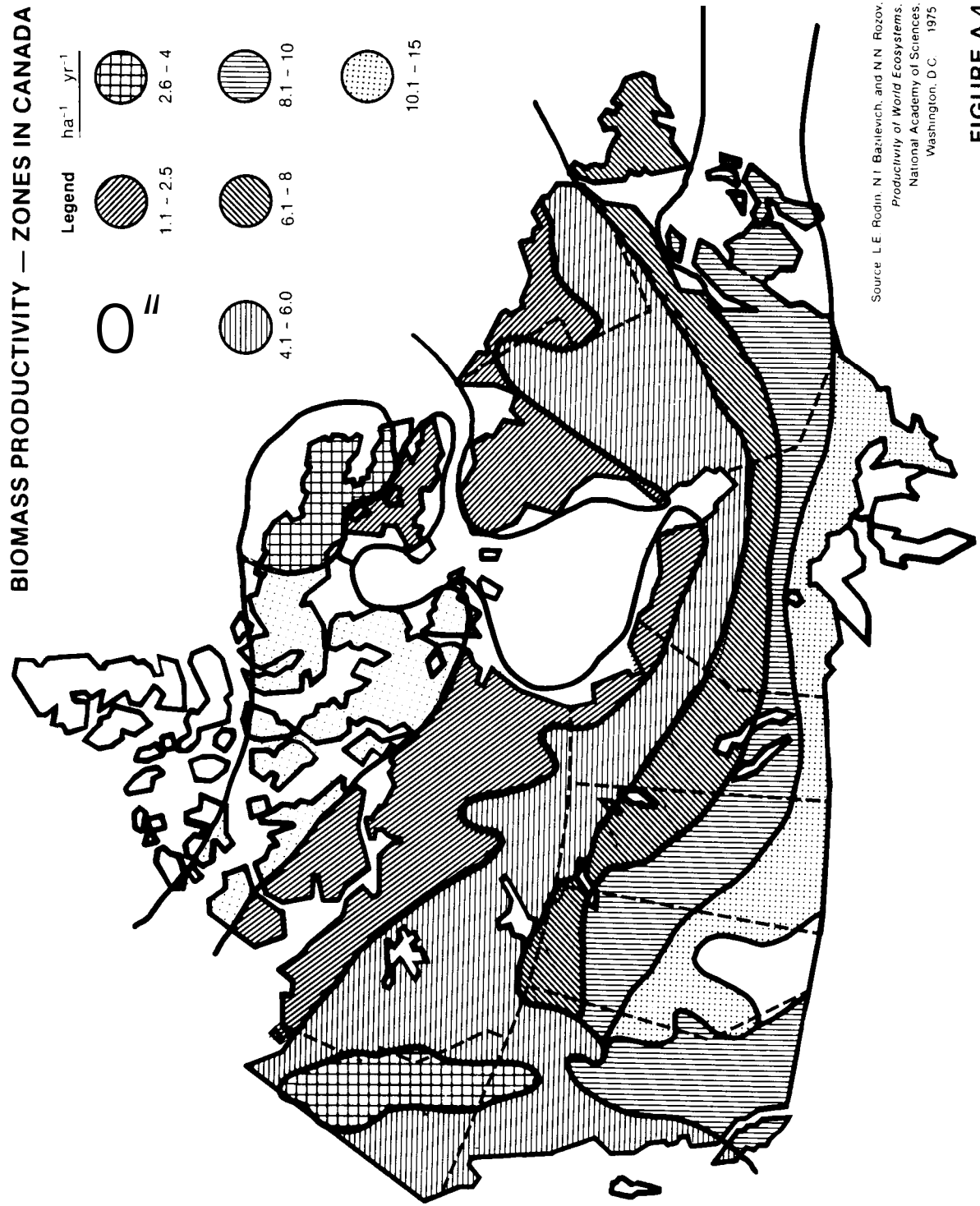
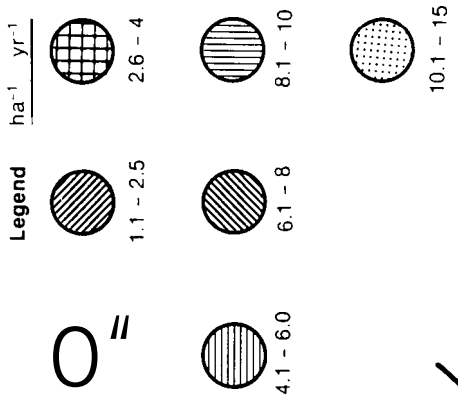

Source: L.E. Rodin, N.I. Bazilevich, and N.N. Rozov.
Productivity of World Ecosystems.
National Academy of Sciences,
Washington, D.C. 1975

FIGURE A.4

Long term renewability, hence sustainability of Canada's forest biomass potential is dependent not only on cutting rates but also on biomass productivity rates. Figure A.4 shows that biomass productivity generally is highest in the southern parts of the country, where the demand for energy is concentrated. However, afforestation in southern areas, particularly the establishment of energy plantations, would increase the potential for land use conflicts with, for example, food and recreational uses.

b) Technology

Forest biomass can be used as firewood for domestic or industrial space heating purposes. It can also be burned to produce electric power or industrial process heat. At present, a number of pulp and paper operations across Canada utilize forest and mill residues to produce both process steam and electricity. This approach not only provides energy for the mill but offers a very simple and convenient solution to the forest slash problem (i.e. logging residues) which can be an obstacle to reforestation efforts. In Ontario, the town of Hearst has proposed a scheme by which mill residues would be transported from sites within a 60-mile radius of the town to be burned in a 20 or 30 Mw electricity generating station.

In addition to producing heat and electricity by direct combustion, biomass can be converted to solid, gaseous or liquid fuels which greatly enhance its versatility. A number of systems are available to transform raw residues into dry fuel in the form of pellets, briquettes or firelogs, thus permitting the fuel to be efficiently transported and used at distant locations. Wood and bark can be converted to a combustible fuel gas by means of a thermochemical process carried out in a variety of reactor designs, of which fluidized bed systems appear to offer the greatest applicability. There is considerable potential for the use of this gas to fire existing boilers, lumber and veneer dryers, pulp mill lime kilns and other uses in and near forest industry mills. thereby replacing conventional fossil fuel consumption. Wood gasification also offers the most immediate opportunity for the conversion of biomass to liquid fuel, since it is the first of a series of processing steps that can be used for the large scale production of methanol motor fuel. One estimate places annual potential production of methanol from forest biomass at 45 million cubic metres (180 million barrels of gasoline) by the year 2000 which would be the amount of biomass supply potentially available if the price were about \$36/ODt. This estimate is the liquid fuel equivalent produced annually by 4 tar sands plants (assuming 125,000 gal/day plant) (1). It is also possible to produce liquid fuels from wood by fermentation (to ethanol) and catalytic direct liquefaction, although substantial development work is still necessary to determine the economic feasibility of these processes.

The Department of the Environment is devoting considerable effort to biomass in its Energy from the Forest (ENFOR) program and in studies designed to facilitate the development of biomass for energy purposes. (3)

c) Environmental Implications

Intensive forest management for energy production can lead to a number of environmental problems, particularly where energy plantations are developed. These include: i) displacement and loss of natural plant and wildlife populations; ii) erosion; iii) changes in the soil chemistry induced by irrigation practices; iv) pest epidemics; v) depletion of soil nutrients; vi) increased run-off which pollutes waterways (fertilizers and pesticides) and causes flooding; vii) aerial pollution from fertilizers and pesticides; viii) introduction of exotic tree species (and their potential for escape and infestation elsewhere); and ix) effects on local climate (trees tend to moderate climate).

On a global scale, large-scale deforestation and wood burning for energy production in countries such as Canada, the USSR, Brazil and the USA could increase the concentration of atmospheric carbon dioxide sufficiently to accelerate climate change. However if clear cuts are promptly reforested, and the more intensive cultural practices bring about a greater growth and photosynthetic activity, the energy forest would help to alleviate the CO₂ problem over the longer term.

Biomass conversion processes (liquefaction or gasification) will produce air emissions which, depending on the characteristics of the fuel used, will include CO, CO₂, and liquid and gaseous hydrocarbons. Environmental controls will be essential in order to limit emissions to acceptable levels.

Emissions of air and water pollutants occur from wood-fired thermal plants. However, although sulphur is present in wood and wood wastes, emissions of sulphur dioxide should be relatively minor. As with coal combustion, wood burning also releases variable quantities of CO₂, CO, HCl, and NO_x as well as polycyclic organic matter and particulate, all of which are related to environmental and health problems. However, certain of these emissions will be greater than those from coal combustion. Emission control devices will be required on large scale wood burning facilities.

Both wood and coal combustion also leave considerable bottom ash to be disposed of, but the former is a more useful nutrient containing material that could be re-applied in the forest. The application of ash, however, would not offset the need for nitrogen fertilizers, although there would be some variation

among sites as to how soon nitrogen would be required and in what intervals. Loss of organic matter could also be a serious factor where whole-tree harvesting methods are used.

Widespread direct combustion of wood for space heating would produce smoke and haze problems, particularly in urban areas, which would necessitate restrictions on wood burning. The emissions contain particulate matter, polycyclic organic matter, carbon

monoxide and various carcinogens, all harmful to human health. If improved combustion designs prove adequate to control these emissions, restrictions on wood-burning stoves in urban areas may not be necessary. Nevertheless global levels of particulate pollution will be affected. This could change the heat balance of the earth since particulate both reflect and absorb radiation from the sun and the earth. (Of course particulate emissions come from all other combustion sources as well).



A-8 Municipal Solid Wastes

a) Resource Potential

The increasing costs of energy are stimulating a rapidly growing interest by both governmental and private authorities in the recovery of energy from municipal solid waste (MSW). Furthermore, as urban populations grow, cities are becoming increasingly burdened by the problem of garbage disposal. Environmental impacts caused by water, air and soil pollution, as well as land requirements, are considered to be major limitations to continued waste disposal by dumping.

Table A.3 demonstrates that the supply of MSW in major Canadian cities from the year 1985 to 2025 would be considerable.

In terms of economies of scale, it appears the MSW is feasible for communities with a population of 10,000 people or more. In Canada there are 163 municipalities in this category with a total potential equivalent to 19 million barrels of oil annually, available from their aggregate solid waste stream (assuming a 75% conversion efficiency from incineration and steam generation).

b) Technology

There are two preferred alternatives for the disposal of municipal wastes: material recovery (recycling) and energy recovery either by bulk burning or through the production of refuse derived fuel. The alternative which provides the greatest net energy benefit is difficult to establish. Some studies have indicated that material recovery is superior to energy recovery in terms of net energy. However, the preconditions of availability of segregated materials, markets for recovered material and necessary infrastructure required to implement resource recovery are difficult to obtain due, in part, to economic and institutional factors which tend to favour the use of virgin materials over recycled materials.

From an environmental point of view, materials recovery is the preferred option over energy recovery, to the degree it obviates the need to, for example, harvest trees and produce pulp and paper. Further-

more, an intensive "energy from waste" program in an urban area would tend to institutionalize the production of waste by creating demands for a steady stream of combustibles to fuel the plant. This could reduce the incentive to adopt a vigorous recycling or reuse program (e.g. newspaper collection) or any other conservation measure which might idle a large capital investment and perhaps disrupt commitments made to supply clients with heat or power.

It is likely that initial development of the energy potential contained within MSW will require the construction of large incinerators with heat-recovery systems, concurrent with sufficient planning to ensure that there is a demand in the vicinity for the thermal energy produced by the plant. There will also be a need for public education programs to encourage separation at source of garbage into organic matter, metals, glass, etc.

In Ontario, the "Watts from Waste" programme sponsored by the Ontario Ministry of Environment was established to separate combustible from non-combustible waste items for incineration in an electricity or steam-producing facility. In Metropolitan Toronto, this process permitted hybrid coal/MSW fuelling in one of the coal-fired boilers at Lakeview Generating Station. Another example is the East Hamilton solid waste reduction unit (SWARU), a large scale heat producing facility which also has the potential for cogeneration.

In the future, it is anticipated that packaged incineration and energy systems will be widely used in small scale applications, using fluidized bed combustion (FBC). FBC is well established for waste-wood incineration and is attractive because of its ability to burn a wide variety of wastes including liquids. In this process, combustion occurs at a low temperature, which reduces the production of NO_x. However, FBC systems still require fuel preparation and the input of pressurized air, which tends to increase the operating costs.

It is difficult to estimate the extent to which incineration plants can be located close to potential customers for steam and the extent to which production rates

TABLE A.3
MSW FEEDSTOCK SUPPLY RANGES: 1985—2025

Region	Cities	1985		2005		2025	
		cost (\$/tonne)	Quantity 1/ (000 tonnes)	cost (\$/tonne)	Quantity 1/ (000 tonnes)	cost (\$/tonne)	Quantity 1/ (000 tonnes)
Central	Hamilton	7.19	195-232	14.88	214-380	15.74	234-619
	Montreal	7.19	1008-1201	14.88	1063-1906	15.74	1120-2926
	Ottawa-Hull	7.19	280-333	14.88	373-661	15.74	494-1306
	Quebec	7.19	213-253	14.88	1188-2106	15.74	1327-3512
	Toronto	7.19	1054-1255	14.88	1188-2106	15.74	1327-3512
Manitoba	Winnipeg	8.12	214-255	13.34	236-418	14.20	259-682
Alberta	Calgary	0	204-242	0	312-554	.25	469-1245
	Edmonton	0	230-273	0	324-574	.25	449-1192
West Coast	Vancouver	2.82	450-536	6.67	533-943	7.96	618-1635

Source: InferGroup Consulting Economists Ltd.

1/Cellulosic tonnage at 35 percent moisture content; costs include processing and evaluation of opportunity values relative to coal; ranges of tonnage represent different assumptions about MSW generation rates and the proportion dedicated to materials recovery.

Note:

The MSW feedstock supply data were compiled with the end use of liquid fuel production in mind but it is evident that the feedstock could also be used in power production through combustion,

would be able to match load requirements. In Denmark, 60% of the country's total municipal waste stream is utilized to produce useful heat energy. In Canada, less than 5% of municipal wastes are used for this purpose. However, an increase in waste incineration/heat recovery installations is possible over the next 20 years to the point where 30-50% of the 163 larger Canadian communities are included. Energy savings, in this event, could amount to about 7 million barrels of oil annually.

c) Environmental Implications

Incineration of wastes reduces volume by 90-95% and weight by 70-75%. This reduces substantially the area of land required and the associated leaching of pollutants into ground water. Certain airborne emissions associated with incineration of municipal solid wastes such as particulate, NO_x and CO₂, are roughly comparable in amount and concentration to

those resulting from use of fossil fuels, while chloride emissions are higher, and SO₂ emissions are considerably lower. Proper control can reduce particulate and chloride emissions to acceptable levels.

A potential problem may arise from the production of highly toxic organic compounds as a result of the burning of plastics, PCB'S and other chlorinated organics. The greater part of the organic compounds, including dioxins, could be retained in the fly ash removed by electrostatic precipitators. Nevertheless, unless there is a program to separate out the precursor materials of the organic compounds before burning, there would inevitably be a proportionate increase in their production with the accompanying problem of disposal of the fly ash.

The increasing household use of chemically sophisticated products such as aerosols, pesticides, herbicides, fungicides, preservatives, etc., can affect stack emissions also. Ash residues and waste waters could also pose pollution problems.

A-9 Geothermal Energy

a) Resource Potential and Technology

Geothermal energy is found where faults and fractures in the earth's crust allow heat from the interior of the earth to rise close enough to the surface to permit exploitation. Geothermal energy can be used for process heat, district heating or for generating electricity with a steam turbine.

Canada's geothermal energy resources are found primarily in the western sedimentary basin (Figure A.5) and are extremely large. There has not been any indication thus far to suggest the presence of a significant quantity of easily accessible geothermal energy in other parts of Canada, and extremely deep geothermal resources are currently not economically exploitable. However, beyond the year 2000, and as technical expertise becomes available, this situation may change.

Only high quality vapour-dominated hydrothermal reserves are used commercially to generate electricity in North America, but both vapour and liquid-dominated hydrothermal energy are used elsewhere in the world. The two cycles under consideration for liquid-dominated hydrothermal use in steam turbines are flashed steam, whereby steam is formed by sudden pressure reduction, and the binary cycle in which a heat exchanger is used.

500 Mw of commercial generating facilities are being operated at the Geysers steam reservoir in California and there are plans for an additional 1,000 Mw by 1985. Other utilities in the U.S. also have plans for the development of geothermal energy. Already developed in areas especially favoured by geology, high quality hydrothermal resources will probably be widely developed by the 1985-1990 period, at least in the U.S. In Canada, for example, the University of Saskatchewan is planning to use geothermal energy to heat a large auditorium. However, large scale development of low-temperature sources is not likely before the year 2000.

In the next few decades, as heat pump technology becomes further developed, more widespread tapping of geothermal sources close to communities for heating shopping centres, industrial complexes, etc. will become feasible. There are a number of communities in B. C., the Yukon, and NWT which could tap this source,

b) Environmental Implications

Estimates suggest that a 1,000 Mw geothermal power plant would require a land area of some 30 km² which may create land use conflicts.

Air pollution is a concern, since noxious gases are often a by-product of geothermal wells. Geothermal steam contains entrained solids and non-condensable gases, CO₂ being the principal one, with varying amounts of hydrogen sulfide (H₂S), methane (CH₄), hydrogen (H₂), and ammonia (NH₃). Hydrogen sulfide emissions are a health hazard for plant employees as well as an odour pollutant for surrounding areas. The presence of these gases and solids in the steam requires that special attention be given to pollution control. (However, uses may be found for some of these by-products, e.g. production of fertilizers from NH₃). Surface and ground water could also be seriously affected from toxic and thermal releases,

In addition, withdrawal of fluids from geothermal reservoirs may cause local land surface subsidence. Subsidence is generally abated by injecting the spent liquid brine back into the ground via reinfection wells. This reinfection system, used extensively in the oil industry, should prevent surface water pollution, but migration of spent brines into drinking water aquifers is still a possibility. Reinfection also inhibits the escape of mineral contaminants and gases into the atmosphere, thus adding greatly to safety and environmental acceptability of the geothermal option. However, potential seismic disturbances could result from geothermal extraction and reinfection processes. Solid wastes created by drilling geothermal wells may also be hazardous to the environment,

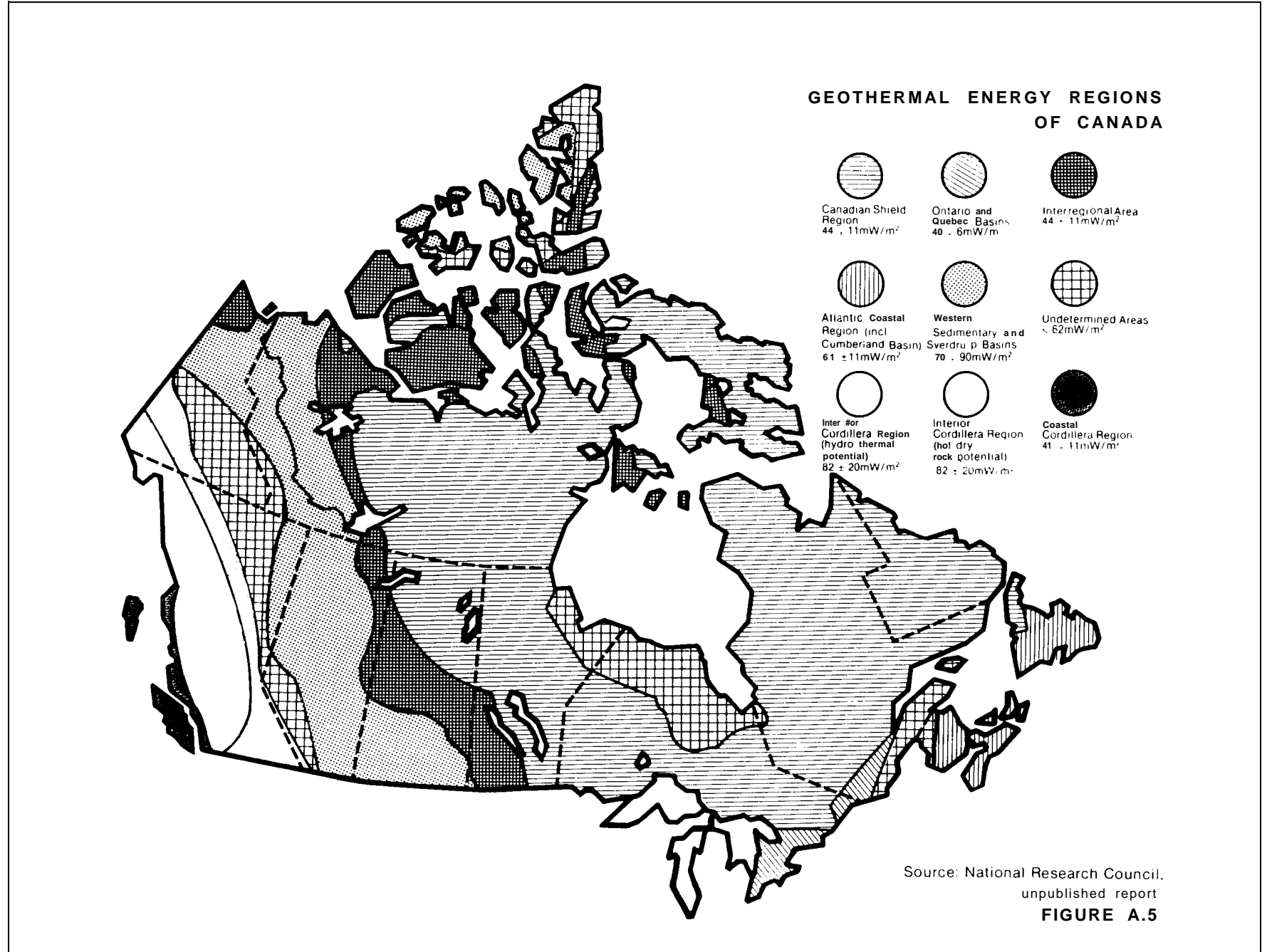

A-10 peat

a) Resource Potential and Technology

Canada has a total estimated fuel peat reserve of 530,786,000 tons which is equivalent to over 700 million barrels of oil (Figure A.6 and Table A.4). One estimate has put the production of power from peat at 100 Mw by the year 2000 coming from 2 power stations tied into the power grid. This would be the equivalent of a half million barrels of oil. (While there is no commitment at this time to produce energy from peat, the current costs of oil and coal suggest that peat is quickly becoming economically viable as an energy source.)

In addition to power generation, peat can be used for district heating, industrial and agricultural heating, and gasification. It has other uses unrelated to energy, not the least of which is its use in the important peat moss industry.

b) Technology

The technology for the harvesting and burning of peat in utility type boilers is well developed as demonstrated by successful installations in Ireland, Finland and the Soviet Union. In Canada, the cost of power from peat is higher than hydro-electric power

but is considered to be somewhere between the cost of oil and coal. As the cost of conventional fuels continue to rise, it is likely that a competitive method of harvesting peat will be developed for Canadian conditions. This, in conjunction with the development of a lower cost boiler plant, would make a peat harvesting/power generating complex economically viable on a commercial scale in Canada. It would also be attractive from the point of view of the production of power for the isolated regions where peat exists.

c) Environmental Implications

The elimination of peatlands and wetlands generally conflicts with wildlife and migratory bird uses as well as some agricultural uses. The extraction of peat removes a sink for CO₂ and a soil/land ecosystem which likely cannot be restored. However, rehabilitation for other purposes such as agriculture or tree farming may be possible. The combustion of peat would produce a waste disposal and air pollution problem — the former being particularly important to resolve in the north where the ecosystem is delicately balanced. The latter, air emissions, are similar to those of wood and therefore would be similarly injurious to human health. More study of this alternative is necessary before large scale development takes place.

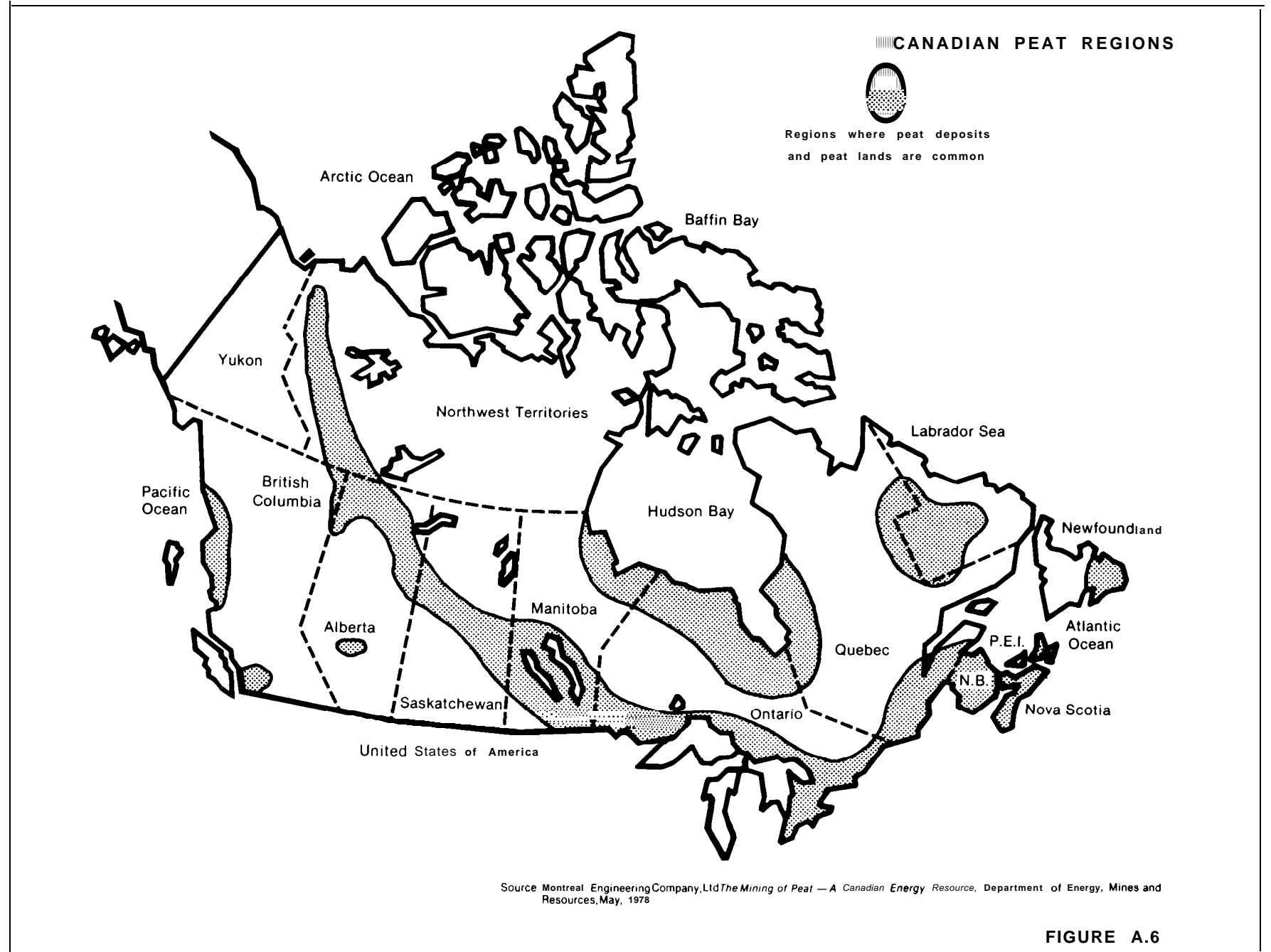

FIGURE A.6

TABLE A.4
SUMMARY OF CANADIAN FUEL PEAT RESOURCES

Province	No. of Bogs	Total Acres	Estimated Fuel Peat Reserves (tons)	Equivalent Barrels of Oil* (106 bbl)
Newfoundland	52	3,150	9,000,000	12.2
Nova Scotia	41	12,743	25,062,000	34.0
P.E.I.	21	3,049	1,933,000	2.6
New Brunswick	40	71,075	138,257,000	188.0
Quebec	79	123,997	71,040,000	96.0
Ontario	56	153,248	149,274,000	202.0
Manitoba	43	261,855	113,620,000	153.0
Saskatchewan	6	38,800		
Alberta	4	3,740		
British Columbia	6	15,400	22,600,000	29.7
N.W.T.				-
Totals	348	687,057	530,786,000	717.5

(1073 square miles)

Source:

Montreal Engineering Company, Ltd., Assessment of Canadian Peat as an Alternative Fuel for Power Generation, for Energy, Mines and Resources, 1978. The conversion is made assuming 55% humidity of peat and incorporates the energy required to dry the peat in the combustion for energy production.

References To Appendix A

A-1 Solar Radiation

- (1) EMR, "Passive Solar Heating in Canada", Report ER 79-6, 1979
- (2) Kendall, Henry W. and Nadis, Steven J. (Editors), "Energy Strategies: Toward a Solar Future" (A Report of the Union of Concerned Scientists), Ballinger Publishing, 1980.
- (3) Hollands, K.G.T. and Orgill, J. G., "Potential for Solar Heating in Canada", February, 1977.
- (4) McKay, D.C. and Won, T. K., "The estimation of solar radiation on various tilted surfaces and azimuths" (Paper presented at Solar Energy Society of Canada Inc. Conference, Charlottetown, P. E.I.), 1979.
- (5) OTA (1 978), *Application of Solar Technology to Today's Energy Needs*, Vol. 1. Office of Technology Assessment, Congress of the U. S. A., Washington, D.C.
- (6) Fisheries and Environment Canada, *Renewable Energy Resources in Ontario: Environmental Implications of Solar and Wind Energy Technologies*, May, 1977.

A-2 Wind

- (1) Rangi, R.S. & Templin, R. J., "Applications of Wind Turbines in Canada", in Proceedings of 10th World Energy Conference, Istanbul, September, 1977.

- (2) National Research Council presentation to Special Committee on Alternate Energy and Oil Substitution, July 2, 1980.

A-4 Tidal Power

- (1) Tidal Power Review Board, *Reassessment of Fundy Tidal Power*, November, 1977.

A-6 Thermal and Salinity Gradients

- (1) Ditmars, John D., "Ocean Energy Resources — The Impact of OTEC", 1980.

A-7 Biomass

- (1) Inter Group Consulting Economists Ltd., "Liquid Fuels From Renewable Resources: Feasibility Study", Vol. C. Forest Studies, March, 1978.
- (2) Morris Wayman Ltd., "Wood-Fired Electricity in Eastern Ontario" (Submission to the Royal Commission on Electric Power Planning, Toronto, Ontario), 1978.
- (3) Environment Canada, "Energy from Biomass Study: A Collection of study outlines and corresponding first drafts as submitted by the authors", September 17, 1980 (unpublished).

APPENDIX B

ALTERNATIVE TECHNOLOGIES FOR ENERGY CONVERSION

Appendix B: Alternative Technologies for Energy Conversion	61
B-0 Introduction	63
B-1 Coal Liquefaction and Gasification	66
B-2 Fluidized Bed Combustion	69
B-3 Magnetohydrodynamics (MHD)	71
B-4 Combined Cycle Power Generation	74
B-5 Hybrid Fuel Combustion	76
B-6 Hydrogen Energy	77
B-7 Fuel Cells	78
B-8 Nuclear Fusion	79
References to Appendix B	81

B-O Introduction

Most of the alternate technologies discussed in this Appendix involve the use of coal as a main fuel source. However, in the case of nuclear fusion (B-8) coal is not a consideration. Also, in the case of hydrogen energy (B-6) and fuel cells (B-7) other fuel inputs may be substituted for coal (e.g. hydroelectricity, solar).

Coal Fuel Cycles

The first part of the conventional coal fuel cycle (Figure B-1) in its basic form involves the extraction, upgrading (preparation) and transportation processes. The coal is then burned and the steam or heat resulting from the combustion is used for power generation or direct heating processes. The alternate technologies of the coal fuel cycle discussed in this appendix parallel the first part of the conventional cycle. However, at the conversion and combustion stages, the cycles diverge.

The environmental impacts associated with the conventional coal cycle serve as a useful base from which to discuss the environmental impacts associated with alternative coal technologies and their associated fuel cycles. A brief review of the more significant environmental impacts of the conventional coal cycle follows.

The mining and upgrading stages have local environmental impacts. Either strip mining or underground mining is used to extract coal. Strip mining has severe impacts on the land as it generally pre-empts most alternate land uses for long periods of time. Both strip and underground mining have the potential to contaminate and/or disrupt water resources. Dust releases resulting from the mining create air pollution which will also impact upon land and water processes, and can also be harmful to human health. The storage, handling, preparation and transport of coal by rail or water also have associated land use requirements and environmental impacts such as the release of dust particles, gaseous pollutants (NO_x , SO_x , CO , CO_2 etc.), noise and aesthetic problems.

Serious environmental impacts from the coal fuel cycle occur at the combustion and conversion stages.

The main impacts arise from air emissions. Air emissions include SO_2 , the major component in acid precipitation which is currently considered to be the most serious environmental concern in Canada. Excessively acidic precipitation is harmful to atmospheric, terrestrial and aquatic ecosystems. It should be pointed out that SO_2 emissions can be effectively controlled (up to 90%) with flue gas desulphurization (FGD) abatement equipment. FGD has been proven to be effective and is in wide use in the United States for combustion processes which release large amount of SO_2 .

Coal combustion also releases NO_x and this too is a major component in acid precipitation. NO_x and its derivatives have toxic and corrosive qualities which affect human health, as well as metals, plastics and paints. NO_x in the atmosphere may also influence the ozone balance, and when washed from the atmosphere, will contribute to eutrophication.

The burning of fossil fuels also results in CO_2 emissions. The increase of CO_2 concentrations in the atmosphere is largely a result of the combustion of fossil fuels. Higher CO_2 concentrations are expected to increase global mean temperatures. The potential for disruption of agriculture, other climate sensitive human activities and also energy demand patterns is a major concern. The utilization of alternate energy sources which result in a lower net production of carbon dioxide is therefore essential over the longer term. Finally, in addition to the above mentioned emissions, the burning of fossil fuels also results in the release of toxic compounds, radionuclides, hydrocarbons and CO into the environment.

Process waters arising from the coal conversion stage may contain, among others, tars, oil, phenols, ammonia, sulfate, arsenic and lead which are generally harmful to terrestrial and aquatic life. Thermal cooling waters from coal combustion also alter aquatic thermal regimes when reintroduced into water bodies, thereby affecting aquatic life in the area.

The solid wastes of the coal combustion and conversion stages also pose serious environmental problems. Combustion wastes consist largely of bottom ash, slag, fly ash, chemical slurries from water

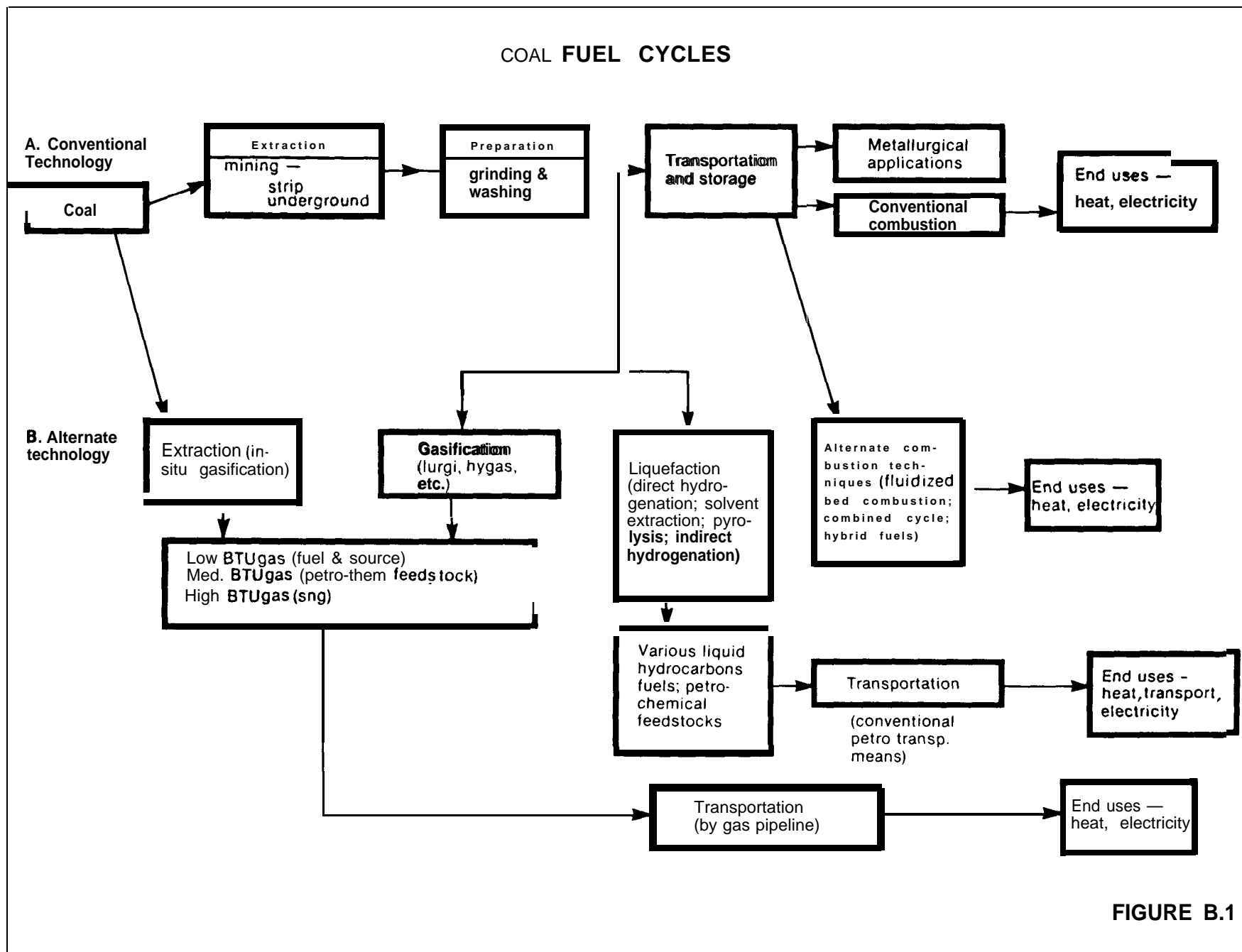

FIGURE B.1

treatment, and stack scrubber waste. The solid wastes contain a variety of harmful substances including arsenic, sulphate and chloride compounds. These wastes have the potential to contaminate ground water and also adversely affect local land use,

Many of the environmental impacts throughout the coal fuel cycle can be mitigated by appropriate abatement measures and equipment. A considerable energy potential exists for Canada in the form of conventional coal utilization technology in conjunction with improved pollution control equipment such as FGD. For the alternative technologies discussed in

this section which utilize coal as a fuel source, the types of pollutants are generally the same although the products of liquefaction and gasification contain a much greater number of carcinogens than are found in natural oil and gas products. The major differences in the environmental impacts are distributional and relate to the combustion and conversion stages. In some cases impacts are less than those of conventional technologies. At this time no comparative assessment of the relative advantages or disadvantages of the various coal conversion options exists for Canada.

B-1 Coal Gasification and Liquefaction

a) Technology

Coal gasification and liquefaction provide a means for increasing the supply of gaseous or liquid fuels. Synthetic fuels (i.e. "syn-fuels") can be produced to have physical and chemical properties, including heat values, similar to natural gas and fuel oils respectively. Thus, the potential exists to substitute these fuels for "natural" fuels in areas such as electric power generation, residential and industrial space heating, and industrial process heat and chemical processes.

Coal gasification and liquefaction would likely be site processes, (i.e. the conversion stage in the coal fuel cycle takes place close to the mine site). Thus, transportation of bulk coal over long distances for power generation would be eliminated (transport of coals (i.e. metallurgic) for other combustion uses (coking) would continue. Once the synthetic fuels are produced, they can be transported to the refinery (in the case of chemical feedstocks) or to the end user largely through existing pipeline systems.

Coal gasification involves treating coal with air or oxygen and steam to yield a synthetic fuel which, after processing, consists mainly of carbon monoxide and hydrogen gases. This can be accomplished with or without first mining the coal. In the latter case, this is referred to as in-situ gasification. Coal liquefaction is accomplished by heating coal and adding hydrogen. This results in a mixture of liquids and byproduct gases, from which the liquid phase is separated. Depending on the end use, further processing may be necessary before the liquid can be used as fuel or chemical feedstock.

Conversion of coal to synthetic fuels requires a substantial input of process energy. The resulting loss in net energy of producing synthetic fuels from coal as compared to conventional coal combustion would be in the range of 30% to 40%. Thus the economics of producing synthetic fuels from coal are currently not attractive for widespread use when compared to conventional fuels. Even with continued escalation in world oil prices, the economics of syn-fuel plants are constrained by the large and continually escalating

capital requirements (currently estimated in the \$2 billion range) and the uncertainties surrounding regulatory decisions.

In the longer term the large coal reserves of Western Canada could make this an attractive option in this region. Alberta, followed by British Columbia are the most likely sites. However, even with government incentives, it is unlikely that large scale production of synthetic fuels from coal will occur in Canada before the 1990's, in the absence of government policy. When production does occur, it is likely that the syn-fuels will be used first for premium purposes e.g. for transportation fuels, for petro-chemical feedstocks, for residential heating fuels, or at power generation plants where environmental problems are of particular concern.

b) Environmental Implications

As coal gasification and liquefaction are likely to be site processes, the environmental impacts of bulk coal transport (or power generation) are largely eliminated. However, the environmental impacts associated with pipelining the resulting syn-fuels would have to be considered. Also, as site processes, the major impacts associated with coal syn-fuels cycles are more concentrated locally. This transfer of some of the major environmental impacts—mainly air emissions and solid waste disposal problems—away from the point of use has obvious environmental quality advantages for user areas, particularly those close to large population concentrations. However, moving the source of air emissions from one location to another without properly containing them provides only a temporary benefit. It must be remembered, however, that some of the syn-fuel products would go to market areas and the use of these products would result in air emissions. The environmental impacts at the conversion site will require special measures to ensure impacts are kept to a satisfactory level since coal burnt as plant fuel is usually low quality coal,

The quality (in terms of cleanliness) of the synthetic fuels produced will be dependent upon the type of coal used, the production process, including its efficiency,

and the abatement equipment utilized. Synthetic fuel oils contain carcinogens and, generally speaking, have a greater potential for causing cancer than conventional fuel oils. There are, however, no conclusive data which compare air emissions from conventional and conversion technologies. Until further investigation is completed it is not possible to assess totally the atmospheric polluting potential of gasification and liquefaction.

Air, water and waste problems are created by the conversion processes. It is generally assumed that most harmful materials will be recovered. However, detailed codes, guidelines and regulations will be required to ensure that controls are implemented.

It should be both cheaper and more environmentally effective to remove pollutants such as sulphur at the syn-fuel plant than to control air emissions at each individual syncrude refinery, power generating station or combustion-for-heat facility. This approach could be a more cost-effective way of mitigating the contribution of coal usage to the acid precipitation problem. Thus, a macro-environmental and economic perspective should be taken in designing the syn-fuel plant, which would consider the most effective and cost-efficient way for removing pollutants throughout the entire coal fuel cycle.

Air

The amount and nature of air emissions associated with coal gasification and liquefaction processes are dependent upon the type of process being used, the chemical makeup of the coal, and the type and efficiency of the abatement equipment. As a result of these factors, a direct comparison between the effects of air emissions from conventional coal combustion and coal conversion processes would be difficult. One distinct difference in air emissions exists. Aromatic hydrocarbons suspected of being carcinogenic are produced during the syn-fuel cycle. These are absent or almost totally destroyed in large conventional coal combustion units.

It is believed that more sulfur could be removed from the coal gasification than from scrubbers used on the stack gases in coal fired power plants today. If this can be accomplished with all coal conversion processes, acid rain problems would be reduced. However, because coal conversion technology is still developing, more investigation into this area is required.

The CO₂ released from the coal conversion processes should be significantly less than those from conventional coal combustion. However, since the carbon in the converted fuel gets oxidized to carbon dioxide when the converted fuel is burned, the CO₂

impact from the total coal conversion cycle should be substantially the same as that from the conventional coal combustion.

It is anticipated that similar techniques used to reduce nitrogen oxides from coal combustion plants may be used at coal conversion plants, although it is likely that nitrogen oxide emissions will be less from conversion plants. Scrubbing may be appropriate to remove ammonia and hydrogen cyanides produced. Particulate could be handled using current technologies.

Water

The manufacture of synthetic fuels from coal can require large quantities of water. The principal water requirements are for chemical process and for cooling purposes. Water is also required for mining and the preparation of the coal, the disposal of ash, and land reclamation. The net water consumption of coal conversion processes is expected to be less than half of that of a conventional coal fired steam electric plant, based on equivalent coal consumption.

The chemical need for water results from the hydrogenation process in which water is the source of hydrogen. For coal gasification, the theoretical minimum amount of water to supply this hydrogen would be approximately 2 million gallons per day for a plant manufacturing 250 million cubic feet per day of high Btu synthetic natural gas. Because less hydrogen is demanded in the production of synthetic liquid fuel, chemical water requirements may be one fifth or less of those requirements to produce synthetic natural gas. Chemical water requirements can be significantly reduced through conservation and reuse.

The cooling water requirements for coal liquefaction are less than the requirements for coal gasification. However, thermal impacts from cooling waters which discharge directly into river systems such as those in the Rocky Mountain foothills could be more damaging to aquatic life than thermal plant cooling waters discharged into the Great Lakes even though the relative cooling water quantities are less. Large scale conversion plants in Western Canada would likely require the use of air and evaporative cooling or the adoption of predischarge cooling measures such as cooling ponds.

The principal source of non-thermal water pollution in coal conversion is the chemical process waters. The liquid waste contains tar oils, phenols, ammonia, particulate, CO₂, H₂S, chloride, sulfate, cyanide and ferrocyanide, as well as toxic trace elements. Waste water tars contain a wide variety of organic compounds. Adequate water treatment facilities would be essential to protect water systems. This would be par-

titularly important in areas of limited water supply such as in Western Canada in order to protect downstream uses such as for irrigation, public drinking water supplies and wildlife habitat. Since the chemical composition of waste water from coal conversion processes is unlike that of conventional coal burning power plants its environmental impact is uncertain. Technology is still developing in this area and more investigation is required.

Dependable water supply may be a major constraint to the future economic development of Western Canada. Industry especially needs an assured water supply year round and seasonal variations in the Western river systems are extreme. The establishment of large scale water intensive activities such as coal conversion processes could be limited by development in other sectors such as agriculture and other industrial and municipal use sectors with which it competes for water. Thus, the water requirements of coal gasification and liquefaction conceivably could limit the scale, and particularly location, of conversion operations. Further study is required before more definitive statements can be made.

Solids

As in the case with conventional coal burning plants, coal gasification and liquefaction produce large

quantities of solid wastes which must be disposed of. Solid wastes from coal conversion processes may amount to 200/0 to 400/0 of the mass of the coal feed to the processes.

Because of additional process steps which generate solid wastes, it is expected that coal conversion processes will generate more solids than conventional steam electric plants for equivalent coal consumption. Insufficient information exists at the present time to quantify this accurately. However, it is anticipated that solid waste disposal will impose multi-million dollar annual costs on facility operations. According to the American Gas Association, solid waste production ratios are 5 to 1 and 3 to 1 for gasification and liquefaction respectively compared to conventional coal fired paver plants.

Disposal of these solids may create leaching problems which could seriously affect local surface and groundwater quality. Land requirements and the effect on aesthetics in the vicinity of disposal sites would be substantial, although not as significant in the case of remote sites.

B-2 Fluidized Bed Combustion

a) Technology

Fluidized bed combustion (FBC) is a process in which a fuel such as coal, wood or municipal solid waste is burned in a bed of small particles which are suspended or "fluidized" in a stream of air blown upward through the bed. This process can burn any kind of coal. However, the emission of sulfur oxides may not be effectively controlled to meet desired standards when firing high sulphur, low quality coals without the use of flue gas desulphurization equipment. The FBC process can operate either at atmospheric pressure (AFBC) or under pressure (PFBC). The FBC process is still in the development stage and will require further testing.

Small FBC units are currently being test-operated in the U.S. Canada's first FBC boiler (CFB Summerside PEI) may be commissioned in mid-1982. A combined cycle PFBC demonstration system maybe built by B.C. Hydro and would be commissioned between 1983 and 1985. Large scale utility applications of PFBC likely will not occur before 1990.

b) Environmental Implications

Mining, processing, storing and transporting of coal and limestone have their environmental impacts. The additional impact of the limestone is small, however. For example, one hundred 1000 MW FBC units would consume less than 10% of the present annual US limestone production. Storage and handling of coal and limestone at the FBC site results in further impacts. In general, emission sources resulting from solids storage and the steam cycle are similar to coal-fired combustion system driving a steam turbine. However, fugitive limestone particulate do escape in the FBC process.

Air

Available data suggest that FBC for new combustion sources will not meet EPA SO₂ standards consistently when using coals with a sulphur content greater than 5 percent and FGD may also be required. Exist-

ing combustion sources cannot be retrofitted to FBC and would require the application of FGD if any reduction of the present SO_x and NO_x levels are to be realized. The relatively low temperatures and somewhat lower excess air values associated with the FBC process, as compared with conventional coal combustion, result in lower NO_x emissions which are well under US EPA standards. However, CO emissions exceed those of conventional coal-fired boilers, but these are generally low. CO₂ emissions maybe slightly less than would be the case with conventional combustion, PFBC results in even lower NO_x emissions and has potential for lowering SO₂ emissions and/or reducing the amount of sorbent required by permitting the use of a more easily crumbled dolomite. Experimental data show that typical gaseous hydrocarbon emissions (reported as ppm of methane) are considerably higher for AFBC than for PFBC.

Particle emissions consist of fines separated from the bed. These could be coal ash, unburned coal particles (essentially carbon) and reacted absorbents. The ability of FBC plants to meet particulate emission standards has yet to be demonstrated. However, it is anticipated that particulate control should be similar to that already achieved in conventional boilers burning low sulphur coal.

In summary, emissions of SO₂ and NO_x may be lower for FBC than for conventional combustion units without FDG but particulate plus total hydrocarbons may be higher.

There is concern over emissions resulting from the combustion of wood in FBC or other processes. Recent studies suggest that carcinogenic compounds and also cilia toxic and mucous coagulating agents are released. (See A-7 Biomass for further detail).

Water and Land

Solid waste management is of special concern for FBC systems because of the potentially large quantities of spent sorbent generated. The amounts of solid residues generated in an FBC system are considerably larger than those produced on a dry basis by a

conventional coal-fired plant of similar size employing flue gas desulfurization. Sorbent regeneration could reduce the amount of solid residues generated. However, the particulate and alkalinity associated with limestone pose particular disposal problems.

Trace elements may be concentrated in FBC solid residues, particularly mercury, arsenic, fluorine and

bromine. Any unreacted lime in the spent sorbent can result in a highly exothermic reaction when in contact with water. This heat release is of concern especially with an AFBC spent sorbent. Potential concerns in the leachates are the high concentrations of calcium, sulfate, pH and total dissolved solids, which are above drinking water standards.



B-3 Magnetohydrodynamics (MHD)

a) Technology

MHD generates electricity directly from thermal energy without the step of conversion from heat to mechanical energy as encountered in conventional steam electric generation. When coal is used as the primary fuel in an open MHD cycle, it is combusted at high temperatures (2700°C). The electrical conductivity of the resulting combustion gases is enhanced by the addition of small amounts of a seed material, commonly potassium carbonate. This electrical conducting gas is then forced through a duct at high speed in the presence of a magnetic field, thereby inducing a voltage drop across the gas stream (Figure B.2).

MHD plant efficiency is about 50% compared with 33 to 40% for conventional fossil-fired plants. In order to get the high overall efficiency, MHD plants are operated in conjunction with another heat conversion system, usually a conventional steam cycle. This technology is still in the experimental stage; commercialization is not expected in the U.S. before 1990. Technical barriers exist such as developing materials to stand the very high temperatures required for open cycle MHD.

Close-cycle liquid metal MHD can be operated at lower temperatures and lower magnetic fields but its development is not as advanced as open cycle MHD.

b) Environmental Implications

All present data on MHD pollutants are based on theoretical models and experimental results from small facilities. In the U.S. MHD programs, coal is emphasized as the primary fuel although biomass would seem to have considerable potential. The environmental impacts of mining, processing, storing, transporting and handling the coal would be less than for conventionally generated electricity due to the higher efficiency of the MHD plant.

Air

Because of the high combustion temperatures necessary for MHD, there is a greater potential for increased NO_x emissions as compared to a conventional power plant. However, by operating at fuel/air ratios of 85% using coal, NO_x emissions from MHD can meet EPA standards for conventional boilers. Although tests are still underway, preliminary results indicate CO emissions are small, and CO₂ emissions are comparable to conventional coal combustion.

The MHD process using potassium carbonate as a seed additive provides a built-in method of controlling sulfur dioxide emissions. Experimental results indicate that removal efficiencies can exceed 99% for a 2.2% sulfur coal. It is anticipated that MHD will be able to meet existing EPA SO₂ emission standards, but more data is required.

Particulate emissions will be primarily fly ash with some unrecovered seed additives. Fly ash emissions will contain a larger proportion of fine particles than will conventional coal-fired plants, thus presenting more health hazards if not controlled. However, total fly ash emissions will be much lower than those for conventional coal-fired plants because more than 85% of the ash is removed as liquid slag. Efficient particulate removal is thought to be possible.

There is some concern about emissions of trace elements such as mercury, arsenic, zinc, barium, cadmium, vanadium and selenium.

Water and Land

Water is mainly used in MHD power plants for cooling. Because of the higher thermal efficiency of MHD vs. conventional systems, less water should be required. It is anticipated that water will be used to extract potassium sulfate from the fly ash/spent seed residue collected by control equipment and in the recovery of spent seed. Leaching of trace matter may occur in the seed extraction and regeneration process,

SCHEMATIC ARRANGEMENT OF MHD POWER GENERATOR

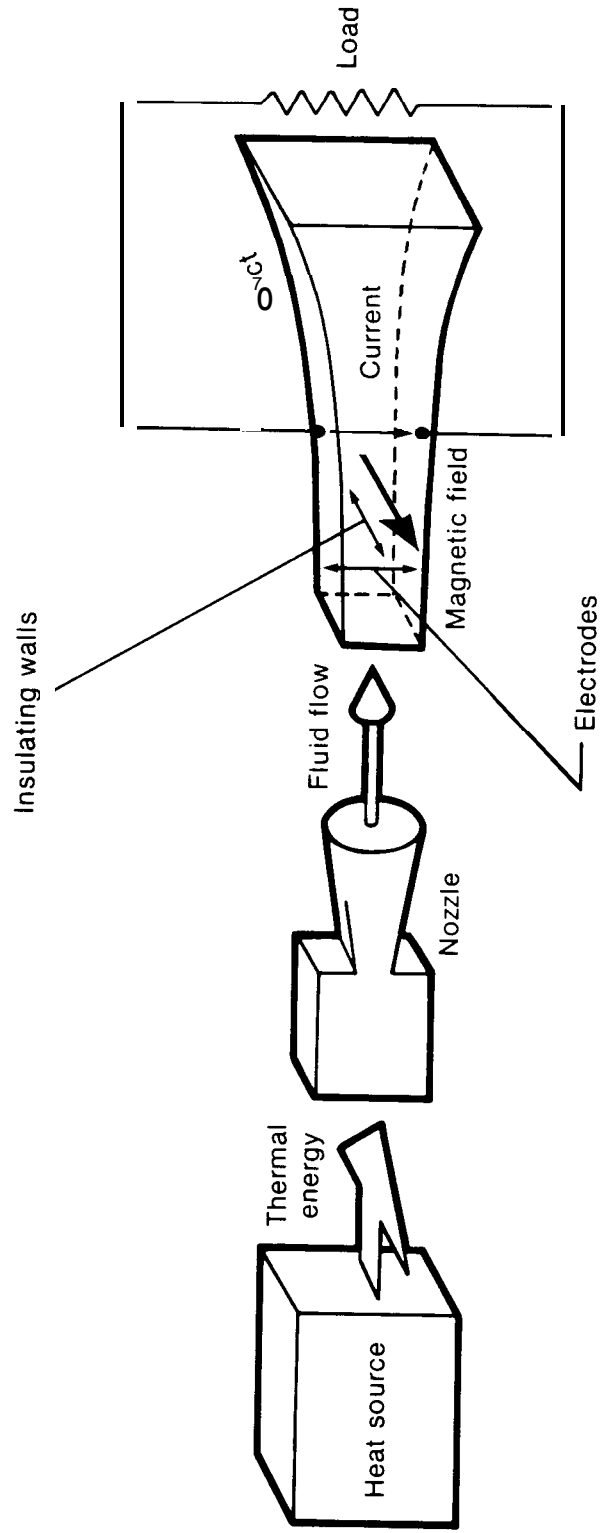

FIGURE B.2

The principal sources of water pollution for MHD are the same as for conventional boilers — i.e., boiler cleaning, cooling systems and feed water treatment. Other areas of potential water pollution are runoff and leachate from solid waste disposal sites.

Solid wastes from MHD plants will contain potassium compounds from seedings, slag and fine particle fly ash. Since no seed regeneration process has yet been established, the solid waste impact from MHD is still uncertain.

B-4 Combined Cycle Power Generation

a) Technology

A combined cycle process combines two different power cycles in such a manner that the combined cycle operates over a larger temperature range than does either of the individual cycles. This produces a higher overall thermal efficiency.

There are two basic categories of combined cycles: recuperative and high-efficiency (Figure B.3). A typical recuperative combined cycle employs an unfired heat recovery steam boiler which uses a gas turbine exhaust as its sole heat supply. In a typical high-efficiency combined cycle, the exhaust gas stream from a gas turbine is a source of preheated combustion air for a fired steam boiler. If, for example, a 50 MW gas turbine is combined with a 450 MW steam turbine, the combined cycle efficiency would be very close to that of the largest conventional steam turbine units currently operating.

Unlike large conventional power generation units, the smaller combined cycle units do not have to sacrifice flexibility for efficiency to the same extent. They can be used for both base load or peaking duty.

A pressurized fluidized bed (PFBC) gas turbine combined cycle, in which the exhaust gases from the PFBC are used to drive a gas turbine, provides an efficiency of about 40%. This, however, presents a

major technical problem. PFBC flue gases contain particulate matter and are capable of fouling, corroding and eroding gas turbine blades. Alternatively, heat may be removed from the PFBC bed with air-cooled tubes and delivered to the gas turbine, or mixed with the flue gas for greater volume. This results in a cleaner gas stream to the gas turbine but the efficiency is not as great — about 38%.

There are several European combined cycle systems already operating. A combined cycle PFBC demonstration system may be built by B.C. Hydro and would be commissioned between 1983 and 1985.

b) Environmental Implications

A proposed U.S. integrated coal gasification and combined cycle system would offer the potential for generating electricity from coal at higher efficiencies than is possible today. The efficiency of this combined cycle-gasifier plant would be 40% or more, significantly higher than the 35-37% of a typical fossil plant using scrubbers.

In general, the higher efficiencies attainable with combined cycle systems, compared to conventional combustion systems of the same size, will result in reduced environmental impacts on air, water and land for the same amount of fuel burned conventionally.

SUPPLEMENTARY FIRED STEAM GENERATOR

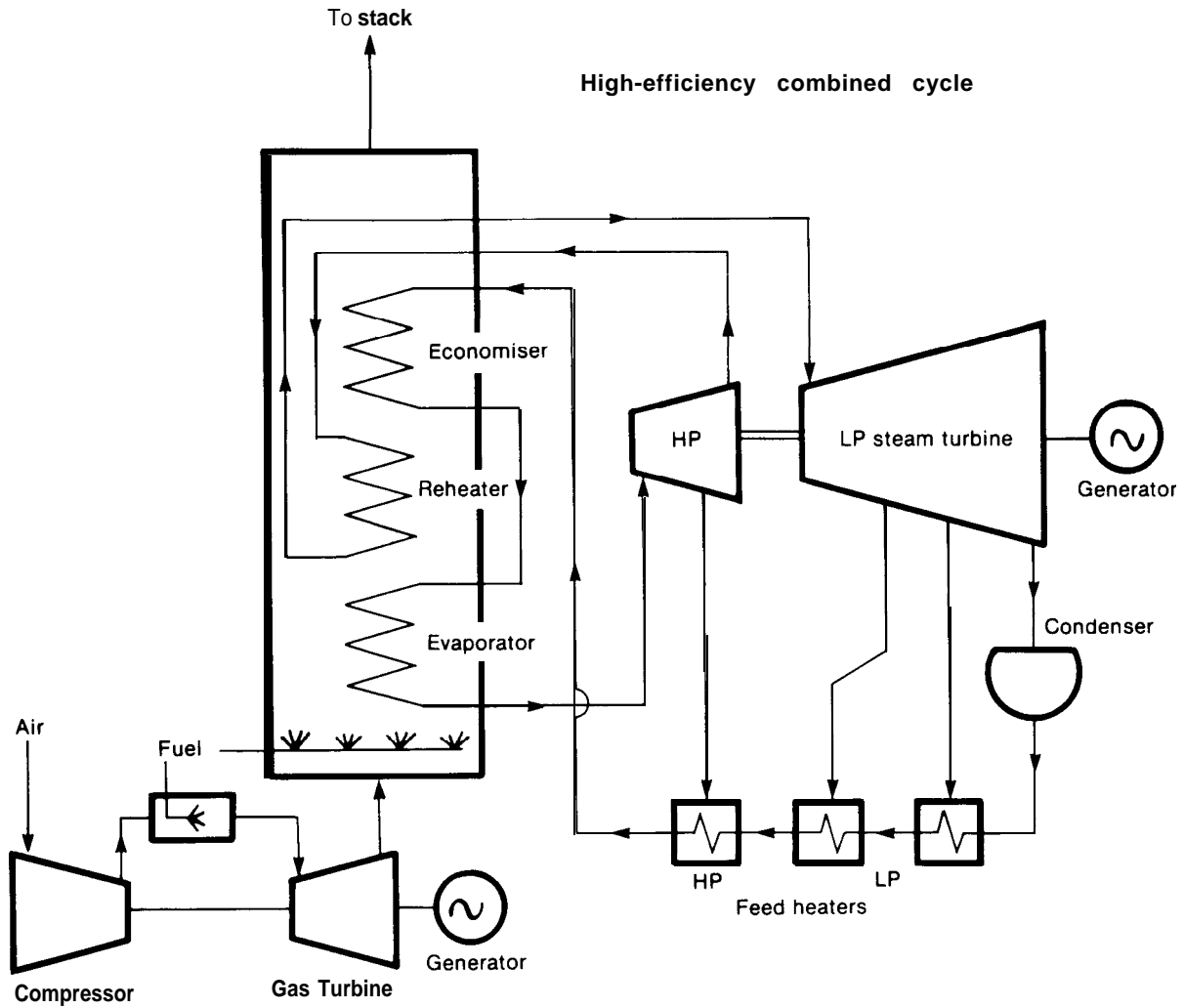

FIGURE B.3

B-5 Hybrid Fuel Combustion

a) Technology

In general, hybrid fuels refer to the burning of two or more different waste combustibles, supplemented with coal or fuel oil to ensure complete, usable combustion. In many cases, the waste material has a high moisture content which prevents direct combustion without prior drying. However, boilers are capable of handling wastes with quite high moisture contents. In its simplest form, bark from logging and sawmill operations is fed to a bark-burning boiler. Combustion is maintained with coal, oil or gas which is used to maintain high temperatures. This technique has been a common practice in the B.C. forest industry for a number of years and is also used in eastern Canada.

There are variations of the basic concept as described above. For example, the bark can be hogged (cut or broken into smaller pieces) and air-dried on land, or dried using low grade waste heat from another source. In each case, the object is to obtain more energy without using high grade energy. Many pulp and paper mills have found that by buying additional bark from saw-mill operations they can become almost self-sufficient in their thermal energy requirements. The limitations on the use of a single fuel source such as bark can often be overcome by supplementing the combustion with another fuel, thus allowing the production of high-pressure steam which can be used efficiently to drive electrical generators. One such installation in Eastern Canada produces 1250 PSIG steam with a bark/oil burner.

The pulp and paper industry, with its easy accessibility to large, guaranteed quantities of wood

residues and bark, is fully committed to utilizing this source of energy. Hybrid systems composed of coal and bark are less common because the sodium and potassium in the bark affects the coal and causes clinkering. Higher ash production and less versatility are additional problems. However, there appears to be no significant technical reasons why this combination could not be used. As yet, there does not appear to be any significant move to hybrid systems using peat.

b) Environmental Implications

There are a number of problems related to hybrid fuel combustion. Hydrocarbons emitted when burning waste wood are currently under investigation as some are known to be carcinogens. Particulate emissions from older installations are a concern but the newer ones generally are able to control particulate better. There is a concern that certain heavy metals may be a problem with both air emissions and decant from wet-ash handling systems. New installations are being examined closely to ensure that any leachates do not get into ground-water systems, and analyses of decant are planned.

Problems associated with many of these installations will be based on scale, since as yet these systems are generally small. However as they become more popular the intensive use of forest products in hybrid fuel combustion systems may result in nutrient loss to soil. This factor would be of particular concern in areas where nutrient inputs to the soil are limited.



B-6 Hydrogen Energy

a) Technology

Hydrogen can be produced from all primary energy sources including solar and, therefore, is essentially a renewable energy source. The gas is an ideal energy storage and transport medium, and is a possible long-term alternative to conventional fossil fuels for both stationary and transportation applications.

Hydrogen can be obtained by electrolysis of water and from hybrid processes such as a solar chemical reaction. It may also be obtained from bio-photolysis as well as from fossil fuels, (as is generally the case at present where hydrogen feedstocks are required by industry).

The production of hydrogen from electricity using electrolysis is approximately 70-80% efficient. That is, for every 100 GJ of electricity used to electrolyte water, 70-80 GJ of hydrogen is produced. Of particular importance to the utility is the fact that off-peak power, or electricity produced at remote locations, can be used to produce the hydrogen gas, which can then be transported or stored like natural gas. Electrolysis/fuel-cell systems can be an asset to the development of small-scale hydroelectric or wind-power systems where the problems of transmission and synchronization with the provincial power grid may be constraints. However, the difficulty of storing and handling hydrogen gas safely is still a major problem. Hydrogen may, however, be used as a major feedstock for the production of fuel alcohol and this would be cheaper to transport and safer to handle.

b) Environmental Implications

Aside from the handling and storage aspects, the major environmental impacts associated with hydrogen energy result from the initial energy feedstocks which are used to produce it. The production of hydrogen from fossil fuels would emit many of the pollutants associated with coal gasification processes, including sulphur dioxide, carbon dioxide, and nitrogen oxide emissions (see Coal Gasification). These pollutants could have a major impact on the environment if a large scale hydrogen energy program based on production from fossil fuels were to develop in Canada. Furthermore, the hydrogen gas which is produced in this way contains a number of impurities, which could impose certain limitations with respect to end use.

Hydrogen produced from electrolysis requires electricity which can be produced either from fossil or non-fossil sources such as hydro-electric power, nuclear power, wind power, and solar-electric power. Each of these energy sources has a number of potential environmental impacts associated with it, most of which have been previously documented. Unfortunately, many of the electrolyzers now in operation emit asbestos particulate and employ nickel catalysts. Since asbestos is a known carcinogen and nickel could be in short supply, health hazards and resource limitations will probably necessitate the development of new technical approaches to electrolysis.

B-7 Fuel Cells

a) Technology

Fuel Cell Power Plants:

A fuel-cell power plant generally consists of three major subsystems — a fuel processor, a fuel-cell power station, and a power conditioner. The fuel processor converts a conventional utility fuel to hydrogen gas; the fuel-cell power station electrochemically converts hydrogen and oxygen to water, while producing direct-current power; and the power conditioner converts direct-current power to alternating-current power. If either hydrogen or a hydrogen rich gas (eg. hydrogen enriched coal gas) is used, the fuel processor can be eliminated.

Fuel-cell power plants may also be used to store electricity. In this situation, off-peak electricity generation provides energy to electrolysis units, which convert water into its elemental components (hydrogen and oxygen). Off-peak electricity can thus be stored in the form of hydrogen fuel until periods of high demand, when the hydrogen fuel is converted back into electrical energy by the fuel-cell power plant. This type of storage would require only 1 per cent of the land area needed by a conventional pumped hydro storage system. Also, where a market exists, some of the hydrogen fuel which is produced could be used for transportation applications. Hydrogen has the potential to be used as an energy storage mechanism for electric vehicles (e.g. H₂ fuel cells for electric motors),

A substantial amount of research and development is being carried out on fuel cells in the US. Fuel cells have been used successfully in the US space programme as spacecraft power plants. The focus of most current studies is to develop cost effective fuel-

cell power plants for use by utilities and industry, and in buildings.

The Use of Fuel Cells in Buildings

Overall energy efficiency can be increased through the use of integrated fuel cell energy systems in buildings. The integrated system extends the on-site heat-recovery concept to include other energy-converting equipment such as heat pumps. In this system configuration, the fuel cell's highly efficient electricity output is used to drive a heat pump in addition to meeting the other electricity requirements of the building. By-product heat from the fuel cell can be used directly for part of the thermal requirements of the building, such as water heating and space heating, as well as to enhance the thermodynamic operation of the heat pump.

b) Environmental Implications

As previously mentioned, the environmental impacts of hydrogen energy are largely the result of the particular energy input which is used to produce the hydrogen gas. At locations where fuel cells are used, environmental impacts would be minimal. However, the dangers of handling and storing hydrogen fuel would require that strict regulations and controls be considered.

Among the advantages of fuel-cell power plants are their reduced nitrous oxide and sulphur dioxide emissions, in comparison to conventional combustion devices, and also their water-conserving nature. These characteristics generally tend to increase the siting flexibility of fuel-cell systems.

B-8 Nuclear Fusion

a) Technology

The generation of power through the fusion of nuclei of two light elements to form a single heavier element, with concomitant release of energy, offers a promising major source of abundant and controllable energy. Significant amounts of power have not yet been produced by this process, but the technology is advancing rapidly, and is now moving from the laboratory experiment to the engineering pilot plant stage. The complexity and expense of producing the high temperatures required (60 to 100 million degrees Celsius, or twenty thousand times that of the surface of the sun), and of handling—"confining"—the reacting substances or fuels at these temperatures means however that progress in developing the technology must be very deliberate. Most estimates do not expect fusion to become a significant practical source of energy until about the year 2000.

Fuel Supply, Raw Materials and Equipment

Although many of the lighter elements are potential sources of fusion reactor fuel, the first industrial-size fusion power systems will be based on the deuterium-tritium-lithium (D-T-Li) fuel cycle. Deuterium and tritium are isotopes of hydrogen. The energy is produced by the fusion of deuterium, tritium and lithium, and the raw materials are ordinary water and lithium minerals. Present technologies also require additional helium as a coolant. This is obtainable commercially from natural gas or from the atmosphere.

Although the concept is theoretically well understood and experimental demonstrations are encouraging, many problems have to be overcome before nuclear fusion becomes a practical source of energy.

b) Environmental Considerations

Under normal operating conditions, the chief predictable environmental concern connected with a fusion power system is the possible escape of radioactive

tritium to the environment. Environment concerns, other than those associated with radioactivity, appear to be almost non-existent with regard to normal operations of a fusion power plant. Land requirements are modest, as are demands on utility, water and electric services.

There is no conceivable way in which an "explosion" or runaway reaction could occur. Any abnormality would lead to simple ceasing of the reaction. A fusion power plant could be subject to accidents (or sabotage), which could be dangerous to plant personnel because of the large amounts of electrical energy involved, and the heat stresses placed on some components. The most serious potential accident, which conceivably could pose a short-lived environmental danger, would be a fire in the lithium blanket which could destroy the reactor structure, release the accumulated tritium, and burn off the total lithium inventory (up to 600 tons for a 1000 MWe plant). The lithium would be released as molten or gaseous, highly corrosive lithium oxide or hydroxide. All analyses of a "worst case" accident of this kind suggest that the danger from released radioactivity from all sources within the plant would be very small, indeed trivial, compared with the chemical hazard from escaping lithium. A lithium fire would be a danger to plant personnel, but as far as can be postulated, would not present a significant threat to the general public or the environment. It would have to be guarded against and controlled like any industrial chemical non-explosive accident.

Because of the experimental and rapidly evolving technology of fusion power, the composition of the reactor equipment and associated machinery that will be used in practical operation is not precisely known. The environmental implications of producing and refining known materials, such as vanadium, niobium and metallic lithium (some of which have never yet been produced in large quantities) and of fabricating equipment in alloys yet to be determined, are not known.

At the end of the useful life of the plant, the radioactive structure will be subjected to continued heating (so-called afterheat) and will require handling in an

environmentally safe manner. It appears that the total accumulated radioactivity in a fusion reactor will be significant — 1 to 10 billion curies for a 1000 MWe plant after 35 years of operation. This will clearly require careful handling, but it is estimated to be about one per cent of the residual radioactivity of an equivalent fission reactor. Also there will be no "high-level" radioactive products such as those that give rise to the chief concerns from fission reactors. Most of the activation products in a fusion reactor will be beta or beta-gamma emitters, with half-lives of a few months or years. The heat build-up and environmental hazard can be expected to reduce to a vanishingly small level in a period about as long as the plant operation itself. Some components may have long-lived activation products that will require disposal similar to that of low-level wastes from fission plants.

c) Environmental Implications

Fusion power plants may take several forms. They may be used as primary sources of heat, to produce electricity, steam, etc. like any thermal power plant. The environmental effects of such use would be independent of the power source.

The fusion reactor could also serve as a supplier, not of net energy, but of neutrons that could breed fissile isotopes from common non-fissile isotopes of heavy elements (uranium, thorium) and thus enormously increase the efficiency and useable fuel resources of fission reactors. It is this characteristic of nuclear fusion as a source of neutrons that gives some aspects of fusion technology a military or strategic implication. The environmental concerns of fusion-fission hybrids are essentially those of the fission fuel cycle component.

The neutrons produced from nuclear fusion could also be used to transmute accumulated radioactive products that would decay rapidly into stable forms. Thus, neutron transmutation provides a possible means of bringing the radioactivity levels of artificially produced nuclear materials down to levels comparable to the original radioactive substance found in nature. The fusion reaction would then offer an alternative to permanent disposal of nuclear fission wastes in geological formations. Demonstration of this alternative must await the practical operation of a fusion reactor with production of abundant neutrons, but the potential environmental and social advantages of fusion, when compared to fission, are substantial.

References to Appendix B

Health & Environmental Effects of Coal Gasification and Liquefaction Technologies. The Mitre Corporation. Sponsored by the Federal Interagency Committee on the Health and Environmental Effects of Energy Technologies. DOE/HEW/EPA-OI, M78-58. McLean, Virginia. July, 1978.

Health and Environmental Effects of Coal Technologies. The Mitre Corporation. Sponsored by the Federal Interagency Committee on the Health and Environmental Effects of Energy Technologies. DOE/HEW/EPA-04, MTR-79WO01 5901. McLean, Virginia. August, 1979.

Coal Gasification: Energy for the Future. Modern Power and Engineering. November, 1978.

Discussion Paper on Coal. Energy, Mines and Resources Canada Report EP 80-1 E. Ottawa. 1980

Brief to Parliamentary Task Force on Alternative Energy and Oil Substitution. Department of Energy, Mines and Resources. Ottawa. June 25, 1980.

Combined-Cycle Using Gas from Coal Holds Promise for Electric Generation. Power, June 1979.

Gas/Steam Turbine Combination Cycle-One Answer to the Energy Crisis. Evans, R.L. Engineering Digest, May, 1976.

Water Supply Should not be an Obstacle to Meeting Energy Development Goals. Report to the Congress by the Comptroller General of the U.S. CED-80-30, Jan 24, 1980.

Water-Related Environmental Effects in Fuel Conversion, Vol. 1. Summary. Water Purification Associates, Cambridge, MA, Prepared for Ind. Environ. Research Lab, Research Triangle Park, N. C., EPA. Oct. 1978.

Water Intake, Wastewater Production and Treatment, and Air Pollution Control Technology in Coal-Fired Steam Electric Power Generating Stations. CH₂M Hill Canada Ltd. Report EPS 3-WP-80-1, Ottawa, January 1980.

APPENDIX C

OPPORTUNITIES FOR IMPROVED EFFICIENCY IN ENERGY UTILIZATION AND FOR INTERFUEL SUBSTITUTION

Appendix C: Opportunities for Improved Efficiency in Energy Utilization and for Interfuel Substitution	83
C-0 Introduction	85
C-1 Co-generation	86
C-2 District Heating	89
C-3 Heat Pumps	91
C-4 Alternate Transportation Fuels	92
References to Appendix C	95

C-O Introduction

In times of cheap abundant energy, little attention was given to fuel efficiency. As energy prices continue to escalate, supply and utilization systems are now being examined with a view to conserving energy. Increases in energy efficiency which lead to a net reduction in energy consumption with a corresponding reduction in exploitation and energy production, are environmentally attractive.

This section presents information on technologies designed to improve efficiency in energy utilization and interfuel substitution. While optimization of the potential of energy sources is entirely feasible, in many instances it can be a costly undertaking since current design practices do not always allow for the most efficient use of the energy source. However, as energy costs rise, resource optimization will become an increasingly important consideration.

C-1 Co-generation

a) Technology

Industries that produce a large amount of process steam, such as the pulp and paper and chemical industries, can generate electricity by first passing this steam through a turbine and driving an electrical generator. The low-pressure exhaust from the steam turbine can then be used as process steam, while medium-pressure requirements can be satisfied by steam extracted part way through the turbine. The electrical output from this type of process is essentially limited by the steam requirements of the particular industry. From a utility point of view, the advantages of co-generation relative to conventional centralized power generating facilities include:

- reduced fuel cost — (by 30-60%) — as a result of a reduction in total energy consumption;
- reduced capital cost and site acquisition problems for new capacity,
- incremental equipment acquisition and shorter lead times to respond to changing energy needs;
- reduced environmental problems.

Because generation and utilization take place on site, the installed cost of a cogeneration plant does not usually involve the cost of transmission. When the transmission losses associated with central power generation and the energy losses associated with waste heat discharges are taken into account, the efficiency of cogeneration can be approximately double that of a conventional centralized facility, depending on the design of the cogeneration installation. Figure C-1 provides a general overview of the cost and potential savings of cogeneration. For example, assuming that a customer has a requirement for 3,850 Kw and 31 million BTU of steam per hour, he would probably buy electricity from the electric power utility and his heating fuel from an oil, gas or coal company. The 3,850 Kw would require an input of approximately 45 million BTU per hour of primary energy at a central electric power generating facility. This combined with the 31 million BTU per hour of direct thermal load, equals a total of 76 million BTU

per hour. If, however, the customer were to install a generator producing the 3,850 Kw and 31 million BTU per hour simultaneously, the total primary energy requirement would be only 49 million BTU per hour, representing an energy saving of 35 per cent.

Across Canada, a number of cogeneration possibilities exist, many of which have already been demonstrated. Most of the pulp and paper mills in British Columbia, for example, generate power as a by-product of process steam, using bark or other forest residue. In Ontario alone, thermal generation capability owned by industrial concerns in 1977 totaled 510 Mw. Such facilities include the DOW Chemical gas-turbine and steam combined-cycle system at Sarnia, and the Great Lakes Paper operation at Thunder Bay. In addition, in Espanola, the E.B. Eddy Company is already generating 17 Mw from cogeneration facilities. Furthermore, the Ontario Ministry of Energy is examining a number of other cogeneration possibilities including one in North Bay that would use municipal refuse and wood waste from Nordfibre Ltd.

Whether utility or industry owned, the market for low-grade heat should be considered when new thermal generation possibilities are being explored. Integration of a group of industries as in an industrial park, could provide the economy of scale necessary to justify the construction of new generating facilities. Such a configuration would facilitate the utilization of the waste heat normally lost in the various industrial and power production processes.

b) Environmental Implications

The environmental impacts of cogeneration are largely dependent on the type of fuel used to produce the steam and the availability of the appropriate pollution control technology, particularly if coal is used. There are environmental advantages to the use of by-product fuels, such as municipal or forest wastes, for cogeneration (Appendix B). Cogeneration as an energy conservation technique is one way of potentially reducing emissions through decreased fuel requirements. Cogeneration also reduces the quantity

AN EXAMPLE OF THE ENERGY SAVINGS RESULTING FROM cO-GENERATION

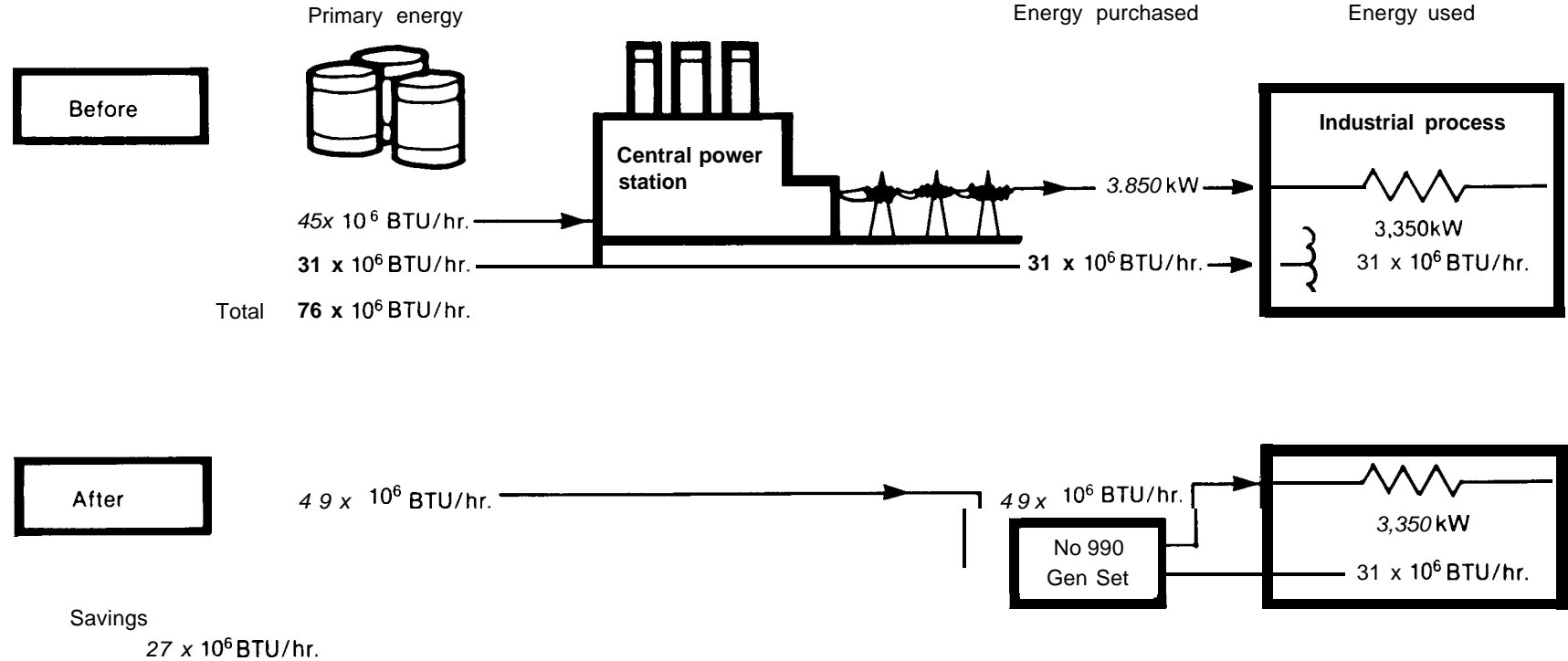

Source: The Garrett Corporation

FIGURE C.1

of waste heat releases and, correspondingly, the associated environmental impacts.

According to Mr. A. Juckymenko of Cogeneration Associates Ltd. in a previous submission to the Committee, the technical cogeneration potential in Canada has been estimated to be 3000-4000 Mw.

Assuming that this cogeneration potential would reduce the overall energy input that would otherwise be required by 35%, then the equivalent of 1600-2200 Mw of conventional power generating capacity could be displaced. In this situation there would be a corresponding reduction in the environmental impacts associated with power generation.

C-2 District Heating

a) Technology

The term district heating refers to the commercial supply of steam or hot water for heating purposes. At present, there are only five true district heating systems in Canada. Four of these, located in Vancouver, Winnipeg, London and Toronto, were developed to supply heat to large commercial buildings in the downtown business districts. The fifth district heating system is in Inuvik, N. WT.

For most district heating systems, underground insulated water or steam distribution systems are preferred, primarily because the ground acts as an insulator, reducing energy losses. A 1977 study prepared for Energy, Mines and Resources suggests the use of the municipal water supply system as the distribution system for a district heating scheme. In this scheme, heat pumps installed in residential dwellings would serve as heat exchangers, transferring heat from the supply of warmed water to the air within a dwelling.

With the high front-end capital costs of nuclear power generating stations and the associated requirement to produce electricity at high capacity factors, considerable attention has been given to the possibility of utilizing the low-grade heat that is a by-product of the electricity generating process. This low-grade heat represents 60-70% of the initial energy content of the fuel. By utilizing this heat in place of electricity for space heating purposes, the seasonally peaking part of the utility's load is reduced. Thus, total installed peaking capacity can be reduced. In this respect, district heating offers the additional advantage of capacity management.

For example, at present, CANDU stations which are operated as baseline facilities in Ontario convert 29% of their thermal energy to electricity while the remaining energy is discarded as waste heat. In a district heating scheme, the temperature of the heat discharge would have to be higher than at present, and, although slightly less electricity would be produced, the byproduct heat used for low temperature heat represents a more efficient use of primary energy. It is anticipated that a CANDU-based district heating

scheme would probably produce electricity at an efficiency of 20%, while 40% of the energy potential would be at a high enough temperature for space-heating applications. For Ontario Hydro's current approved nuclear commitment of 13,800 Mw by 1990, this would imply a reduction of electricity output by approximately 4,200 Mw. However, there would be a corresponding thermal output of approximately 17,000 Mw, which could be available for district heating applications. Assuming an average household peak demand of 20 kw, this would be enough energy to heat 850,000 households.

A study of district heating prepared by Acres Shawinigan Ltd. for the Ontario Ministry of Energy (February 1976) and numerous other subsequent studies agree that district heating using nuclear power stations has obvious long-term economic advantages, particularly where new industrial or residential subdivisions are being planned nearby. In addition, the Ontario Energy Corporation has undertaken to develop two test greenhouse facilities, one at Pickering and another at Bruce County, in an attempt to explore the feasibility of using by-product heat from Ontario Hydro's nuclear power generating facilities in those areas. A proposal for the use of district heating not involving nuclear power is presented in the Energy Feasibility Study for Phase B of the St. Lawrence project, prepared for the City of Toronto by the ECB Group. It is possible that a number of proposals to develop district heating will emerge across Canada where base load power generating facilities are situated close to a potential low temperature heat market.

b) Environmental Implications

As with cogeneration, the environmental impacts of district heating are largely dependent on the type of fuel which is used to produce the steam. District heating systems concentrate the environmental impacts of energy conversion at one source, thereby eliminating the dispersed impacts of multiple sources (e.g. air emissions from furnaces in buildings and houses). Adequate pollution abatement equipment must be installed at the generating source. In addition,

the installations of steam distribution equipment may temporarily disrupt existing land use patterns. However, to be feasible, district heating requires higher density development, This implies a permanent change in land use pattern.

District heating is environmentally attractive due to the increased efficiency of fuel utilization. If electrical energy production requirements and district heating demands are fairly coincident, there could be a con-

siderable reduction in the localized pollution from multiple sources, together with the reduced impacts throughout the associated fuel cycles due to increased efficiencies. At the same time, there is little increase in the pollutants produced at the central facility over those associated with producing electricity alone, There would also be a decrease in waste heat releases and entrainment effects if these systems operate a closed-loop circuit. Hence, a substantial net environmental advantage can be realized.



C-3 Heat Pumps

a) Technology

The heat pump provides an alternative to conventional systems for residential and commercial space heating. A heat pump system is based on the same components as a refrigerator and operates according to the same principle.

Conventional heat pumps have been used successfully since 1949 for residential applications, as well as in a number of large office buildings. The efficiency of a heat pump is largely determined by the temperature of the ambient air or equivalent heat source. The higher the temperature of the source medium (e.g. air, water, or rock), the more efficient the heat pump will be. With ambient air temperatures in the range of -4°C to 16°C , commercially available heat pumps can improve the efficiency of an electrical heating supply by at least 50%. This can be further improved, particularly at the lower end of the temperature scale, if an alternative heat source can be utilized, such as the water in a well or even the municipal water and sewage system.

In the past, most heat pumps were sold on the basis of summer air conditioning requirements. However, with rising heating fuel bills, the winter energy savings that are possible with a heat pump are becoming increasingly attractive. Even with the requirement for an auxiliary heating system for very cold days, heat pumps can still offer significant energy savings.

In an all-electrical heat pump system, resistance heaters are used to supply approximately two-thirds of the heating requirement on cold days. This tends to have a negative impact on the utility's electric power load curve. On the other hand, both the add-on hybrid heat pumps, which use a conventional combustion furnace for auxiliary heat, can reduce the utility's winter peak, because no additional electricity is required to operate the system on cold days.

b) Environmental Implications

As with cogeneration and district heating, the environmental impacts associated with the heat pump depend on the type of fuel which is used to produce the electricity to operate the device. Similarly, the heat pump is environmentally attractive due to its increased energy efficiency and the subsequent reduction in the need for extracting, transporting and burning fuels.

Where a source of low temperature heat other than ambient air is used, such as sub-surface water, a number of minor environmental impacts could occur, particularly if competing uses for the water exist. It has been reported that a heat pump using a small stream as a source of low temperature heat caused the stream to freeze completely.

C-4 Alternate Transportation Fuels

a) Technology

Alternate fuels for transportation vehicles are limited to the following:

- (i) Electricity — whether generated from hydro, fossil fuels, or nuclear power;
- (ii) alcohols — notably methanol and ethanol;
- (iii) gaseous hydrocarbons — Liquid natural gas, liquid petroleum gas, compressed natural gas etc., plus hydrogen itself;
- (iv) other parts of the crude oil barrel, notably diesel fuel

None of these fuels are truly new since they have all been used off and on in various countries throughout the history of self-propelled vehicles.

To date no alternate fuels have made great inroads due to the economic and technical competition of the market place. Currently, gasoline is the dominant fuel for road vehicles as well as for light aircraft and marine engines. Where gasoline has been supplanted, it has been only (with the exception of some electrified rail and bus) by other parts of the crude oil barrel, notably diesel in marine rail and heavy road vehicles, and kerosene in turbine powered aircraft,

None of the alternate fuels are truly cost-competitive with gasoline at domestic prices. However, these substitutes could become more attractive if domestic crude oil prices rise to world levels or if domestic crude oil supplies are dramatically reduced in the short run or completely unavailable in the long run.

Many countries (e.g. Brazil) are seriously considering replacing some imported petroleum products with more domestically produced fuels to improve their balance-of-payments and security of supply situation. Also, liquid hydrogen for aircraft fuel is currently being investigated. Aircrafts may be using this fuel before the end of the decade. With this objective in mind, both Canada and the U.S. are encouraging this substitution as evidenced by Ontario and Manitoba's

elimination of taxes on gaseous fuels and the lack of a road tax on gasohol in the U.S.

b) Environmental Implications

In analyzing the potential impact on air quality of using alternate fuels, the extent of market penetration will be a factor, as will be the quality and quantity of individual emissions.

In general, there would be equal or lower total emissions of all pollutants if any of the listed alternates were to replace gasoline. The health impact would be especially reduced in the case of electrically powered vehicles. However, environmental problems associated with the generation of electricity by fossil or nuclear fuels would remain a concern. Also, emissions from poorly maintained and/or malfunctioning vehicles would be of particular concern.

The first generation of electric vehicles may include many dc motors, raising the possibility of direct ozone emissions from malfunctioning motors. Also, the emission of new carcinogens from overheated controllers and motors could occur. In addition, there are safety considerations associated with battery storage, particularly in a collision situation.

In the case of alcohol fueled vehicles, the increased aldehyde emissions relative to gasoline are of some concern in even perfectly maintained vehicles. This may, however, be self-correcting on in-use vehicles since the owner should be able to "smell for himself" that his carburation system requires attention.

Gaseous fueled vehicles seem to present no particular problems for air quality, although NO_x emissions will be difficult to control without an adverse effect on fuel consumption.

Vehicles capable of delivering acceptable performance on fuels from other parts of the crude oil barrel undoubtedly will operate very closely to the diesel cycle (perhaps spark-assisted). Accordingly, the total emissions of the common pollutants will be less than for gasoline. However the U.S. EPA is currently

investigated. Aircraft may be using this fuel before cinogens in the exhaust emissions of such engines.

The current emission regulations under the Motor Vehicle Safety Act, administered by Transport Canada, address specifically gasoline and diesel fueled vehicles. Thus, the first three alternate fuels (see Section above) through omission, are exempt from the emission regulations. It would not seem worthwhile to plug this "loophole" immediately. Current conversion costs are sufficiently high that only small-scale work on engines using these fuels is being done and almost all of that as retrofits. Should the major manufacturers plan production of alternate fueled vehicles, then "best practicable technology" emission standards should be developed with sufficient lead time to ensure their consideration in engine design.

In a previous submission to the Parliamentary Committee, a return to leaded gasoline was suggested as an attractive transportation fuel alternative.

It was indicated that a potential savings of 25,000 barrels per day of crude oil in 1990 could be realized by changes in fuel specifications. This was to be done at no extra cost except for changing engine specifications. The proposal was to replace the catalytic

converter with a simple "lead trap" to protect the environment.

DOE disagrees. To meet existing Canadian automobile emission standards, the above proposal would:

- (i) decrease the fuel economy of automobiles because it would be necessary to operate engines at efficiencies below the optimum;
- (ii) increase the automobile cost by several hundred dollars for a lead trap which would have corrosion and maintenance problems;
- (iii) recover only 80% of the lead under the most ideal conditions; and
- (iv) increase operating and maintenance costs to the **motorist because lead and other** corrosive products would deposit in the automobile engine and exhaust system.

Even if Canada were to revoke the automobile emission standards, the previous proposal would not be competitive with the current (catalyst converter and lead-free) automobile option when one considers the total energy -environment-economics situation.

References to Appendix C

c-1 Co-generation

- (1) MacKay, Robin. "Co-generation to the Rescue", Presentation to the EPRI Dual Energy Use Systems Workshop, Yarmouth, Maine, Sept. 1977.
- (2) Leighton and Kidd Ltd. "Report on Industrial By-Product Power", RCEPP Research Project, Toronto, May 1977.
- (3) A. Juckymenko, cd., "Economics of Industrial Co-generation of Electricity", Proceedings of a seminar co-sponsored by the Ontario Ministry of Energy and Ontario Hydro, Toronto, Dec. 1978.
- (4) Dow Chemical Co., "Energy Industrial Centre Study", Prepared for the National Science Foundation, Dept't. of Commerce, Washington, D. C., June 1975.

c-2 District Heating

- (1) James F. McLaren Ltd., "District Heating Information Study", Prepared for the Ontario Ministry of Industry and Tourism, Toronto, May 1978.

- (2) G.T. McLaughlin and M. Rienbergs, "A New and Novel Form of District Heating Using Therms/ Effluents from Electricity Generating P/ants", Office of Energy Conservation, EMR, Canada, 1977.
- (3) R. El. Lyon and R.O. Sochaski, "Nuclear Power for District Heating", Whiteshell Nuclear Research Establishment, Atomic Energy of Canada Ltd., Manitoba, Sept. 1975.
- (4) ECS Group, "Energy Feasibility Study for St. Lawrence Phase B of the City of Toronto", A Working Paper for the Ontario Ministry of Energy, Toronto, July 1978.

C-3 Heat Pumps

- (1) D.R. Young, "Electrical Contractors and Maintenance Supervisors", January 1977.
- (2) Gordian Associates Inc., "Heat Pump Technology: A Survey of Technical Developments, Market Prospects and Research Needs", Dept. of Energy, Washington, D. C., June 1978.