



Arctic Development  
Library

***Environmental Guidelines - Pits And  
Quarries  
Catalogue Number: 9-5-228***

9-5-228

CS

# Environmental Guidelines Pits and Quarries

Prepared by:

**MaClaren Plansearch**

for  
Land Resources, Northern Affairs Program

Funding for the preparation of this Guidelines  
Handbook was provided by the Arctic Land Use  
Research Program.

# Table of Contents

|  |           |                               |           |
|--|-----------|-------------------------------|-----------|
| <b>Preface</b>                           | <b>2</b>  |                               |           |
| <b>1. Introduction</b>                   | <b>3</b>  | <b>8. Quarries</b>            | <b>56</b> |
| Who?                                     | 3         | Planning                      | 56        |
| Why?                                     | 3         | Design                        | 58        |
| How to use the Guidelines                | 4         | Operations                    | 60        |
|  |           | Restoration                   | 61        |
| <b>2. Administration and Regulations</b> | <b>5</b>  | <b>Glossary</b>               | <b>62</b> |
| Acts and Regulations                     | 5         | <b>Appendix A</b>             |           |
| Government and You                       | 5         | <b>List of Contacts</b>       | <b>67</b> |
| <b>3. Planning - Pits</b>                | <b>7</b>  | <b>Appendix B</b>             |           |
| Quantity and Quality of Material         | 7         | <b>Recommended References</b> | <b>68</b> |
| Identify Location of Material            | 8         | <b>Appendix C</b>             |           |
| Sensitive Areas                          | 13        | <b>Conversion Table</b>       | <b>69</b> |
| Schedule                                 | 18        |                               |           |
| Camps                                    | 20        |                               |           |
| <b>4. Design - Pits</b>                  | <b>23</b> |                               |           |
| General Layout                           | 23        |                               |           |
| Contouring                               | 24        |                               |           |
| Staking                                  | 25        |                               |           |
| Placement of Surface Material            | 25        |                               |           |
| Visual Screening                         | 27        |                               |           |
| Access Roads                             | 28        |                               |           |
| <b>5. Operations - Pits</b>              | <b>32</b> |                               |           |
| Preparation of Site                      | 32        |                               |           |
| Method of Excavation                     | 35        |                               |           |
| Sequence of Extraction                   | 35        |                               |           |
| Screening and Crushing Operation         | 37        |                               |           |
| Drainage and Erosion Control             | 38        |                               |           |
| Equipment Servicing                      | 40        |                               |           |
| <b>6. Restoration - Pits</b>             | <b>41</b> |                               |           |
| Future Public Use                        | 41        |                               |           |
| Clean Up                                 | 42        |                               |           |
| Drainage and Erosion Control             | 42        |                               |           |
| Recontouring                             | 42        |                               |           |
| Topsoil and Overburden Replacement       | 44        |                               |           |
| Revegetation                             | 44        |                               |           |
| Monitoring and Maintenance               | 45        |                               |           |
| <b>7. Permafrost</b>                     | <b>48</b> |                               |           |
| What is it?                              | 46        |                               |           |
| Where is it?                             | 46        |                               |           |
| Permafrost Indicators                    | 47        |                               |           |
| Problems                                 | 48        |                               |           |
| Sequence of Operations                   | 51        |                               |           |
| Processing                               | 55        |                               |           |

# Preface

This Handbook presents some environmental guidelines for pit and quarry development and restoration in the Yukon and Northwest Territories. The Handbook recommends operating procedures that are both sensitive to the environment and efficient for the operator. The myth that environmentally 'sound' operations cost more and take more time is dispelled; in its place is the suggestion that good pit management saves the environment and saves the operator both time and money.

The information presented here was obtained by talking to a number of administrators and operators in the Yukon and NWT. We would like to thank all these people for their time and help.

The photographs were collected from numerous sources, and were taken by many people, some of whom are unknown. Credit must be given to those photographers that we do know Ken Bodden, Keith Byram, John Hudson, J.T. Inglis, L.W. Lamoureux, Bob Larson, B. Moerkoert, Jacques Penel, Archie Pick, Richard Spencer, O.A. Vandenberghe, Donald Wishart. In addition to these erstwhile photographers, thanks must be given to the following for digging through their files and boxes: Perry Savoie, Guy St. Andre, Jack Hiscock, Andrew Forbes, and John Hough.

The study team was given valuable assistance and guidance by a Steering Committee from Indian Affairs and Northern Development. Committee members included: Chris Cuddy, Jack Hiscock, Floyd Adlem and Perry Savoie. The Scientific Authority for the project was Dr. Martin Barnett.

The following people assisted in preparing this Handbook: Archie Pick, Bryony Walmsley, Wendy Wishart; The illustrations were prepared by Lester Jones.

Special thanks must be given to Ric Kokotavich of Image Plus for doing all the photographic work in this Handbook.

This handbook presents environmental guidelines that are useful for pit and quarry operators. The handbook does not establish new standards but sets out recommended procedures to ensure that ecological, cultural and aesthetic values will be preserved within the constraints imposed by the current state of technology.

**THESE GUIDELINES SHOULD NOT BE TAKEN AS ABSOLUTE TERMS AND CONDITIONS. THEY ARE SUBORDINATE TO ALL ACTS, ORDINANCES AND REGULATIONS.**

# Part 1

## Introduction

### WHO?

This Handbook of Environmental Guidelines is for anyone who has anything to do with the planning, design and operation of pits and quarries in the lands north of 60°. If you are a small operator, a big contractor, a Department of Public Works, hamlet council, or an oil company employee, this handbook is for you.

### WHY?

Most people think of the North as a vast, untouched wilderness.



They are wrong. Much of the Northwest Territories and Yukon is being explored, drilled, excavated and paved in the course of some development or other. Just stop and think a minute.

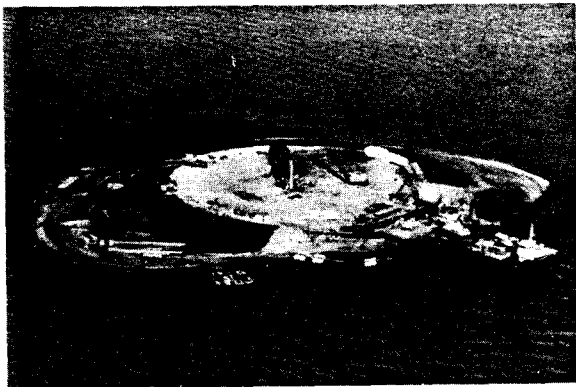

. drilling island



• sand and gravel used to restore drill site

A number of communities in The North are growing rapidly to support the increased amount of exploration and development for oil, gas and minerals. Community building interests, as well as staging sites, drilling platforms, roads, airstrips and camps, all need large amounts of granular material. So far, so good, but there are two problems.

1. Scarce granular resources in many areas.
2. Poor site planning and management at too many sites resulting in an environmental mess.

This handbook aims to assist the operator of a pit or quarry to minimize these two problems. The first problem, lack of material, especially high quality material, cannot be changed, but more efficient operations of pits and quarries maximizing the amount of material excavated, can go a long way toward easing this problem.

The second problem is the primary reason for this handbook. It is a handbook of environmental guidelines aimed to **help** the operator in pit and quarry development and restoration.

It is hoped that after reading this book, the operator will be more aware of the effects of various stages of operations on the environment so that future operations may be less damaging. Also, the operator may find that by following this approach, he will have a more cost-efficient operation.

## HOW TO USE THE GUIDELINES

Part 2 of this Guidelines Handbook is a very brief guide to the regulatory processes that concern pit and quarry operations, who to contact and what permits are needed.

Parts 3-6 follow through the process of planning, designing, operating and restoring a pit. Part 3, Planning, tells you how to locate a pit in relation to the type and amount of material you need and how to avoid sensitive areas. A schedule for access and operations is outlined and some guidelines on camps are given.

Part 4, Design, shows you how to design a pit with sensitivity for the environment and efficient operation and restoration in mind.

Planning and design are important because if you plan and design it right, you save yourself time and money. You also save the environment, and that's important. Part 5, Operations, tells you the best way to prepare and operate a pit.

Part 6, Restoration, gives you guidelines for temporary and complete abandonment of a pit and what you have to do to restore it.

Part 7, Permafrost, deals with the special problems of permafrost. It gives a brief introduction to permafrost and tells you where and how it might be found. This section also looks at some of the problems encountered when operating a pit in permafrost and how to cope with them,

Part 8, is about Quarries. Any special planning, design and operational features which are special to quarries and are not found with pits are discussed here.

A Glossary of Terms is provided and references and contact addresses are listed. For each of the subjects discussed there is a guideline in highlighted capitals, short explanations (text), an illustrative photograph or drawing (usually) and some summary points, (an 'x' means a poor practice and a '.' means a good practice).

For quick and easy reference, you can glance at the summary points and then if you want a fuller explanation you can read the text.

# Part 2

## Administration and Regulations

There are about 25 different pieces of government legislation (Acts, Ordinances and Regulations) which control land development in the North; however, only a few Acts and Regulations apply to pit and quarry development. Nevertheless, the administrative procedure is complex enough to warrant a brief explanation in this environmental guidelines handbook. If you do need more details on administration, you are referred to the "Administrative Guide" published by DIAND. All you need to know in the context of this handbook is which legislation controls pits and quarries, who you must contact and the permits that you need.

### ACTS AND REGULATIONS

The following are brief summaries of some of the major Acts and Regulations which concern pit and quarry development.

**Territorial Lands Act** - provides the authority for dealing with the administration and protection of Territorial (Federal Crown) Lands, which are under the direct control of the Minister of Indian Affairs and Northern Development.

**Territorial Land Use Regulations** - provides regulatory control for maintaining sound environmental practice for any land use activities on all lands under Federal control in the territories. These regulations require that land use permits be issued for, amongst other things, all work involving the use of heavy equipment, establishment of camps, use of explosives and clearing of lines, trails and rights-of-ways.

**Territorial Quarrying Regulations** - set out the fee schedule and the procedures for extracting Crown-owned limestone, granite, slate, marble, gypsum, loam, marl, gravel, sand, clay or stone in territorial lands. The regulations specify permits, applications, staking and dimensions of quarries.

**Fisheries Act** - protects fish and fish habitat from any interference through pollution, blockage or any other structure that impedes or blocks fish movement.

**Northern Inland Waters Act** - licenses water use, prevents pollution by not allowing waste deposition in any water body and allows the establishment of a comprehensive management program.

**Mine Safety Ordinances and Rules** - sets out standards of safety for mining operations in the Yukon and N.W.T. In the N.W.T. it also controls the use and storage of explosives.

**Yukon Blasting Ordinance** - provides controls similar to those in the Mine Safety Ordinances and Rules of the N.W.T.

**Yukon Quartz Mining Act** - concerns lode (bedrock) minerals in the Yukon Territory.

**Yukon Placer Mining Act** - concerns placer minerals in sands and gravels in the Yukon Territory.

### GOVERNMENT AND YOU

#### Territorial Land

The map (see over) shows how the N.W.T. and Yukon are divided up for administration purposes. In the N.W.T. there are six districts, some of which are divided into subdistricts. The Yukon territory is considered as one district with ten subdistricts.

Each district and subdistrict has an office where an operator or contractor must go to seek advice on permit/licence application procedures. The addresses of the offices are listed fully in Appendix A.

The procedures for obtaining permit and licence approvals are being revised, therefore the operator is advised to contact the Inspector and to read the "Administrative Guide" prepared by DIAND.

#### Community Land

Around many of the communities in the N.W.T. and Yukon, the land has been transferred from the Federal Government to the Territorial Government; these lands are known as Commissioner's Lands. Commissioner's Lands were set up to protect community interests, which include the local source of granular material. The Territorial Government and/or the community does the initial opening up of a community pit and then the administration of the pit is the responsibility of the community council. Permits are still required to extract material from the community pit and these can be obtained from the Territorial Government.

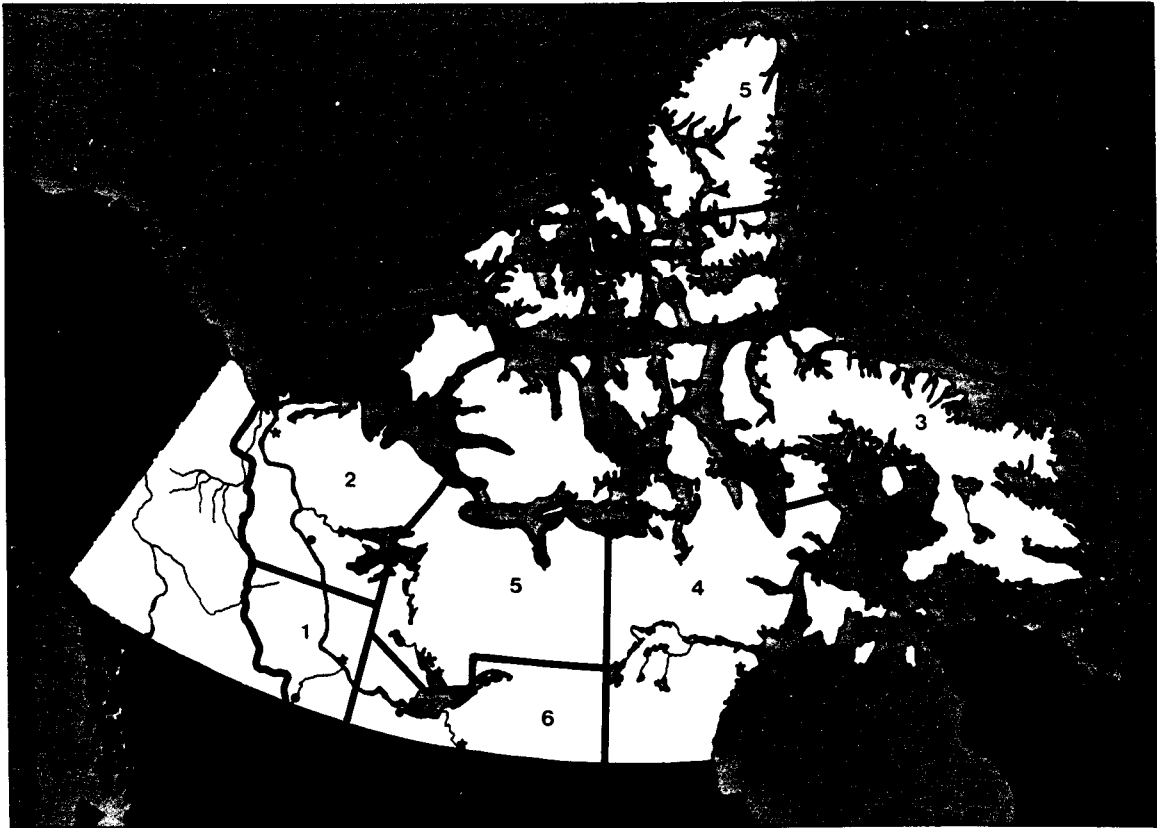

**DIAND RESOURCE MANAGEMENT AREAS**

**Northwest Territories:**

- 1. Ft. Simpson
- 2. Inuvik
- 3. Baff in
- 4. Keewatin
- 5. Yellowknife and Arctic Islands
- 6. Ft. Smith

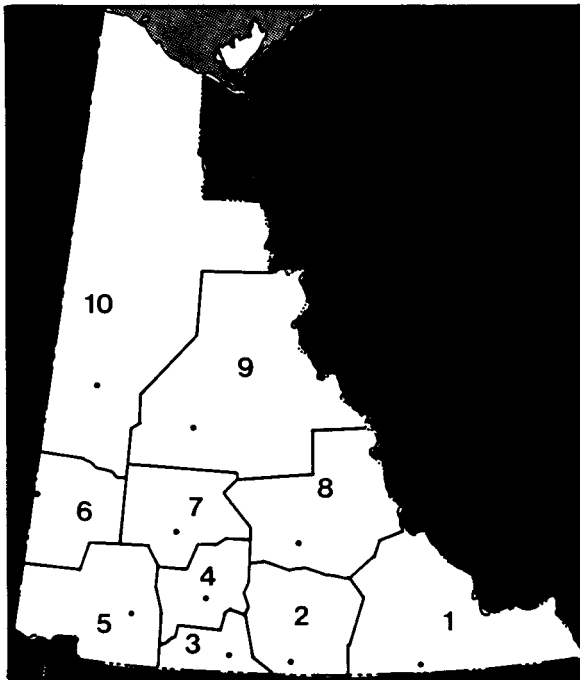

**DIAND RESOURCE MANAGEMENT AREAS**

**Yukon**

- 1. Watson Lake
- 2. Teslin
- 3. Tagish
- 4. Laberge
- 5. Haines Junction
- 6. Beaver Creek
- 7. Carmacks
- 8. Ross River
- 9. Mayo
- 10. Dawson



# Part 3

## Planning - Pits

In order for a pit operation to run smoothly, the operator should plan well in advance. He must know how much and what type of material he needs and where to get it. He must clearly understand how to search for new locations of granular material and why some sources cannot be excavated because of such factors as local drainage patterns, important wildlife areas, present and planned recreation areas and so on. Because of the varying ground conditions with the different seasons, the operator must plan ahead and schedule his activities for the correct time of year. Finally, if the operator is considering using a camp, he must make provision for garbage and sewage disposal.

### QUALITY AND QUANTITY OF MATERIAL

The term 'granular material' is used to describe materials which are commonly known as sands and gravels. Technically granular materials include natural silt from silts to sand, gravel and cobbles.

Deposits of material may be uniform or 'pure' such as sand pits or clay pits, but more frequently, a granular deposit is composed of a combination of material types. The proportion of fines, sands, gravels and larger material varies, so that a deposit may be described as a 'sandy gravel', or a 'gravelly sand', etc., depending on the proportion of each type of material. For most of the uses for granular material, a mixture of grain sizes is desirable rather than a 'pure' deposit.



• sand pit



• clay pit

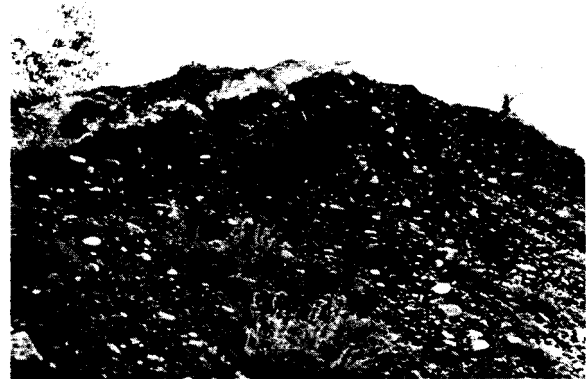

- granular material is sometimes a 'pure' deposit
- granular material is usually a mixture of grain sizes

## Quality

### DETERMINE THE QUALITY OF MATERIAL YOU NEED.

From the chart opposite, it can be seen that different uses require a different type or quality of material. The quality of material is determined from its properties, which include:

- **Shape.** Angular particles compact better than rounded particles for road and pad use, however, rounded particles are more desirable for concrete mixing.
- **Fines:** A certain amount of fine material is required to allow proper compaction of a material, but the amount must be limited, otherwise there could be a dust or mud problem.
- **Cobbles/Boulders:** For many uses a size limit is imposed, for example, for road surfacing there must be no material over 2.5 centimetres in size.
- **Cleaness/ Contaminants:** This property applies especially to concrete aggregate where the amount of fines (clay, silt, mica and organic material) should be minimized. Standard tests can be performed to determine this characteristic.
- **Strength:** The particles for concrete aggregate and rip-rap should be of strong durable material which is resistant to physical and chemical weathering.
- **Ice content:** Ice content in a material is usually a problem since any subsequent melting can result in a collapse of the material. (See Permafrost).

A visual inspection of a material can give a rough estimate to its suitability for a particular use, however, more detailed analysis must be carried out before the material is actually used to ensure that high grade materials are not needlessly removed.

- different quality materials for different uses
- quality determined by properties
- analyse material before using
- identify quality requirements during pit planning

## Quantity



### FIND OUT HOW MUCH MATERIAL IS NEEDED BEFORE EXTRACTION.



The availability of granular material throughout the territories is extremely variable. There is a relative abundance of material in the southern Yukon and in some of the southern parts of the N. W. T., but in the north, central and eastern parts of the N.W.T. and in the Arctic Islands, granular material is scarce, therefore every deposit has to be very carefully developed to get the most from it. The amount of really good, high quality material is also in short supply. For example, poor quality material suitable for general fill cannot be used even with processing, for uses requiring high quality material, such as concrete. Higher quality material therefore, should be kept only for those uses requiring it, not for uses satisfied by a lower quality material.

- resources could be scarce
- optimize use of resource
- conserve high quality material for special uses only
- x do not excavate more than you need

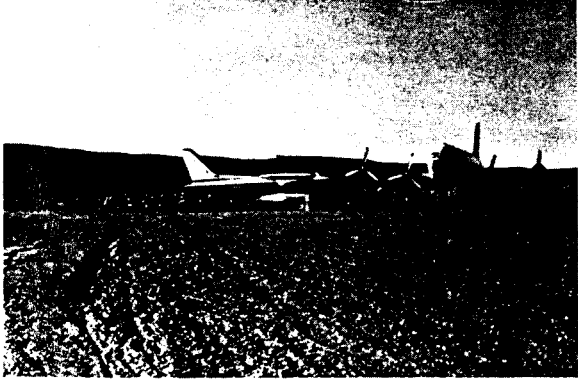
### IDENTIFY LOCATION OF MATERIAL

Once the quantity and quality of material required is determined, a suitable source must be found. Around communities, there is usually an existing pit that will provide the required material, so the operator should go to this source. In some instances a new deposit may have to be opened up, which requires organized and efficient planning. The operator can suggest locations for his extraction, but the final decision is up to the local Inspector.

| ILLUSTRATION  | USE/TYPICAL PROPERTIES   |
|---|--|
|   | <p><b>Concrete Aggregate</b></p> <ul style="list-style-type: none"> <li>- well graded sand &amp; gravel</li> <li>- rounded particles</li> <li>- fine &amp; coarse aggregate</li> <li>- clean</li> <li>- very low quantity of contaminants</li> </ul> |
|    | <p><b>Building pads , staging sites, roads, air strips</b></p> <ul style="list-style-type: none"> <li>- well graded sand &amp; gravel</li> <li>- less than 5% finer than No. 200 sieve</li> </ul>  |
|  |  |
|  | <p><b>Road Surfacing</b></p> <ul style="list-style-type: none"> <li>- well graded granular material</li> <li>- angular</li> <li>- max. size of 2.5 cm.</li> <li>- 10 - 25% finer than No. 200 sieve</li> </ul>                                       |

| ILLUSTRATION  | USE/TYPICAL PROPERTIES   |
|---|--|
|    | <p><b>Road Base and Sub-base</b></p> <ul style="list-style-type: none"> <li>- well graded sandy gravel</li> <li>- angular</li> <li>- less than 8% finer than No. 200 sieve</li> </ul>  |
|   | <p><b>Pipe/Culvert Bedding</b></p> <ul style="list-style-type: none"> <li>- non-frost susceptible sand and gravel</li> <li>- free from large rocks, frozen lumps, ice and organic material</li> </ul>  |
|  | <p><b>General Fill</b></p> <ul style="list-style-type: none"> <li>- Non-frost susceptible sand and gravel, quarried rock and clay till.</li> <li>- free from organic material</li> <li>- free from ground ice</li> </ul> <p><b>Rip Rap</b></p> <ul style="list-style-type: none"> <li>- well-graded cobbles and boulders</li> <li>- resistant to chemical and mechanical weathering</li> </ul> |

## Existing Sources

### USE AN EXISTING PIT IF POSSIBLE

This guideline applies to all operators if an existing source can meet their requirements. Usually it makes better economic sense to extract material from a pit that has already been developed rather than to open up a new pit. In addition, numerous pits in a small area are unsightly and harmful to the environment.

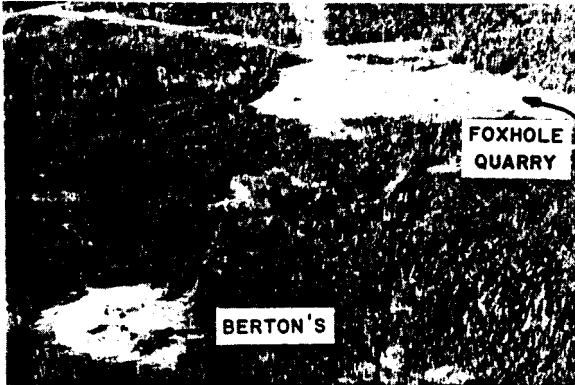

- x poor planning
- x poor economics
- x poor environmental planning

Three problems can occur when the operator uses an existing pit:

1. 'high grading' where high quality material is removed only because it is easy to get at rather than because the operator actually needs the high quality material.
2. 'large pits' -any unmanaged pit can get too large, but care should be taken especially in shallow pits, where excessive amounts of land must be cleared and excavated in order to obtain a relatively small amount of material. In this case, the operator should inform the inspector and request another source of material.
3. 'bony pits' occur when there is an excess of oversized material in the deposit. In these situations, there is a large amount of reject, the material requires crushing, and fines must be hauled in to make a better mix. Report a 'bony' pit to the Inspector,

## New Pits

### DEVELOP A NEW PIT ONLY IF NO EXISTING PIT CAN SUPPLY YOUR MATERIALS

### CHECK THE AVAILABLE INFORMATION BEFORE GOING INTO THE FIELD

Information on potential sources of granular material can be obtained from maps and aerial photographs by identifying landforms that are associated with granular deposits. For the areas surrounding most communities, this information is already recorded or mapped and is available from DIAND, or the Department of Local Government. Usually the information will contain details on the location of the site as well as the quantity and quality of material contained in the deposit. When this information is available, it may reduce or remove the need for the operator to do his own field investigations.

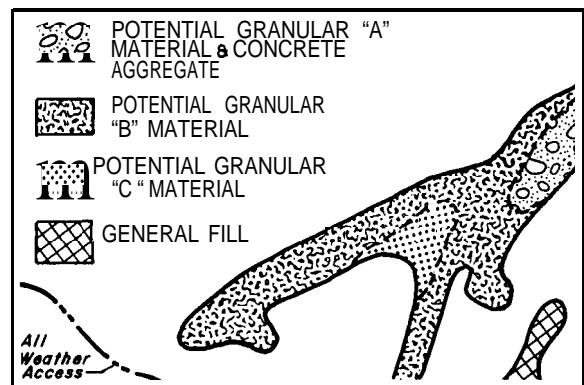

- . information may be available
- no need for additional field investigation

When there is little or no information available, **CARRY OUT YOUR FIELD INVESTIGATION IN A PLANNED AND EFFICIENT MANNER OR CONTRACT IT OUT** to a qualified engineer, geologist or terrain analyst. If your field investigation program is well planned, then it will be efficient. An unplanned investigation can result in random movement through the area damaging the vegetation, and bogging down vehicles due to access during the wrong season. It is a good idea to check to see if any access roads have been already cut through your area of interest, so that you do not needlessly cut another trail.

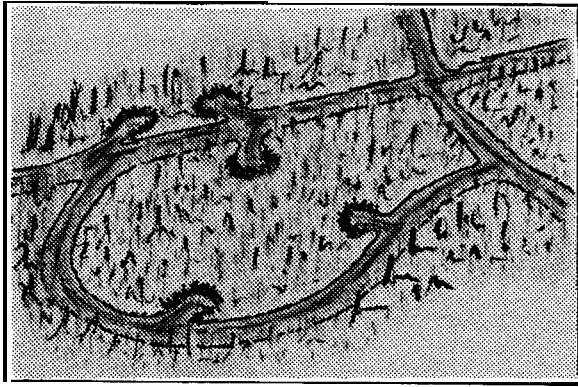

x poor practice

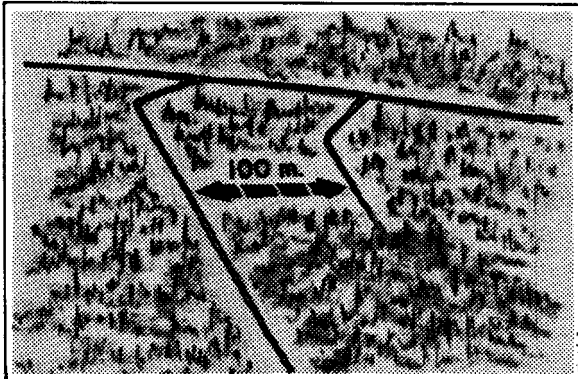

x poor practice

- schedule your investigation carefully
- plan your access
- x do not cut a new trail when one already exists

Proper planning of the search for new sources of granular material involves:

1. Map and air photo interpretation
2. Field investigation

1 ) Map and air photo interpretation is carried out in the office. It involves an identification of all the landforms in the area that are likely to contain granular materials. Landforms may be identified by characteristics of vegetation, slope, soil and drainage (see Glossary). At this time, sensitive areas such as streams, lakes, wildlife and recreation areas are identified (see next section on special areas).

2) The field investigation program involves drilling in winter to determine the quantity of material available and test pitting in summer to assess the quality of the resource. A rough estimate of the quantity of material and its composition can best be obtained by using a 50 millimetre auger and drilling holes on a 50 metre grid pattern. It is advisable to drill in winter to avoid the severe access difficulties that may occur in summer.

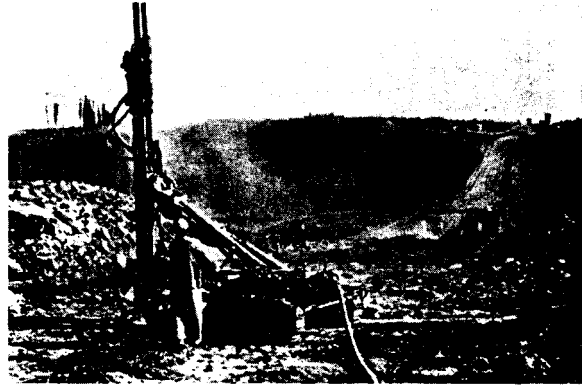

- drill to estimate quantity
- use a 50 mm auger
- . drill in winter
- . drill on a 50m grid

If the deposit looks promising after the drilling program, test pit locations are selected from the air photos, Test pits are dug either by hand or by using a backhoe to a depth of about 4 to 5 meters below grade. A test pit reveals information on soil conditions, type of material and depth to water table. The elevation of the water table is critical to operations, since all excavation must take place above the water table. To obtain an accurate elevation of the water table, the test pit must be allowed to 'settle' for up to 45 hours; the quantity of material that can be excavated may then be determined. Test pits must be dug in the summer due to the freezing of groundwater in winter. With the inspectors approval, some pits may be left open for other operators to assess the material, otherwise they must be backfilled and compacted to grade.

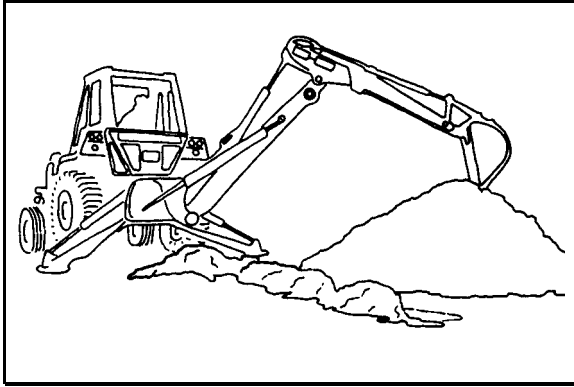

- test pit to determine quality
- use a backhoe or hand dig
- test pit in summer
- locate test pit locations on air photos
- estimate elevation of water table
- leave selected pits open
- backfill and compact test pits

### SENSITIVE AREAS

When a permit is issued, the Inspector will attach a number of conditions to the permit which the operator must follow. Some of the conditions may concern:

- lakes and streams
- wildlife
- archaeological sites and monuments
- recreation areas
- unique geographical features
- permafrost

Any of the above could be disturbed or ruined by the development of a pit or quarry.

### Lakes and Streams

**A PIT MUST BE AT LEAST 30 METRES AWAY FROM A WATER BODY.**

A water body includes any lake, river or stream. The ecological balance of fish, plants and animals in lakes and streams can easily be upset by sediment or blockage as a result of a nearby pit operation. Also, if you excavate below the high water mark, then you could be flooded out, so it is best if you find a gravel source at least 30 metres away from a lake or stream so that you can reduce the risk of such problems. You can find out where streams and lakes are located from a map in your local government office

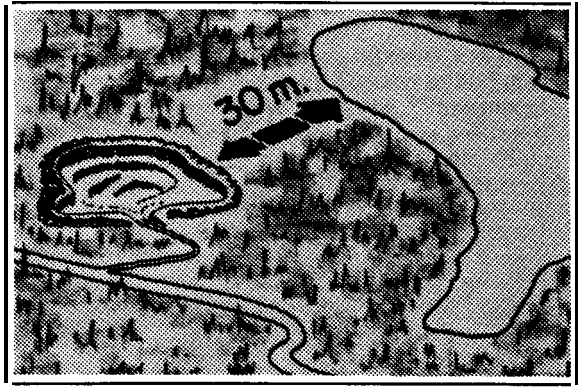

- good practice

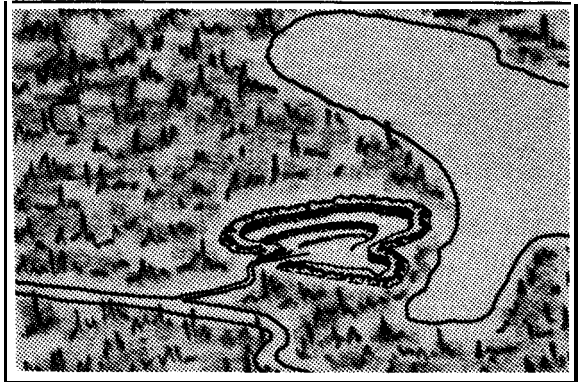

- x poor practice

- check a map for stream and lake locations
- plan to stay away from water bodies
- x pits next to water are a risk for the fish, plants, animals and birds, and your operation

### River Bed Extraction

**EXCAVATE FROM RIVER BEDS ONLY WHEN NO OTHER SOURCE IS AVAILABLE.**

**CHECK THE LOCATION OF YOUR EXTRACTION WITH THE INSPECTOR FIRST.**

Only where there are no other sources of granular material in an area or where environmental damage caused by upland operations would be unacceptable, should river bed extraction be considered. Before a permit can be issued to an operator, clearance will be obtained from the Department of Fisheries and Oceans and under the Northern Inland Waters Act. Approval will only be given if the river is not important for fish, or other uses such as navigation.

Extraction of a large amount of material is not usually permitted because this can cause problems downstream. The amount of material available in a stream depends upon the seasonal changes of the water level. In some years, much more sand and gravel may be exposed than in others, therefore the number of permits issued may vary from year to year depending upon the river conditions.

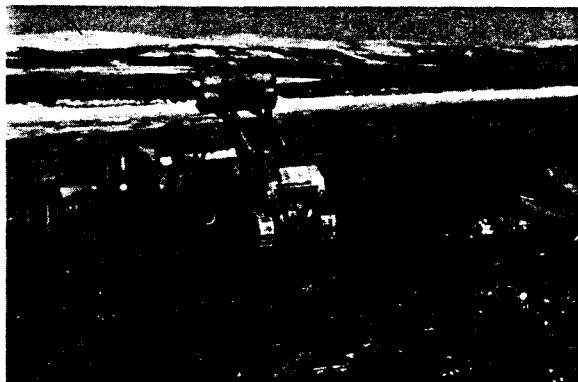

- low water levels in winter allow extraction.

Do not plan to remove sand and gravel below the high water mark of a flowing stream during times when fish occupy a part of the stream at, or below, the pit. Never remove gravel from below the water level of a flowing stream.

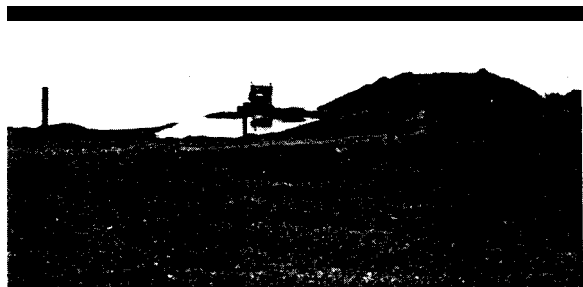

x poor practice

The location of extraction from a river is an important consideration in planning. Extraction on the outside bend of a river is bad because this is where the fastest current hits the bank and gravel removal may result in bank collapse. A better place to remove material is from

the inside of the bend because the current here is slower and this is a zone where the river naturally deposits material. Extraction from sand or gravel bars in the middle of the river may be authorized in certain circumstances.

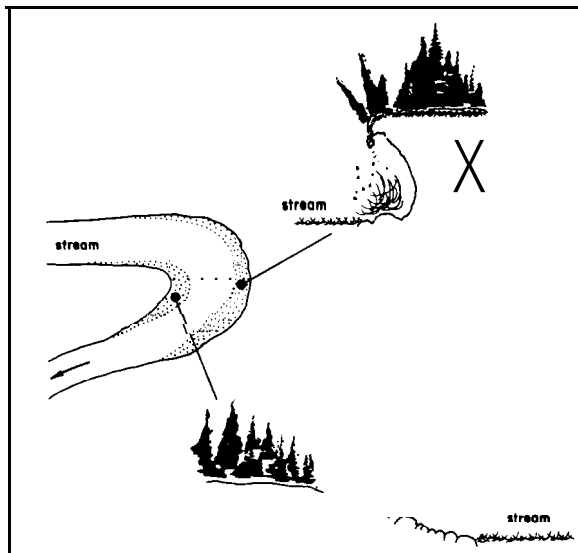

- only extract from streams where there is no other source
- obtain permission
- x do not extract from a fish spawning stream
- x do not extract from the outside of a bend

### Beach Extraction

**EXCAVATE FROM BEACHES ONLY WHEN NO OTHER SOURCES AVAILABLE.**

Like river bed extraction, lake or sea shoreline extraction, should only be considered if there is no other available source. There are three things that may result from beach extraction:

- shoreline erosion
- stranded fish in pools during low water seasons
- disturbed fish habitat

The wave action at the foot of a cliff or high beach is very strong, so if the cliff is weakened by extraction then the whole cliff or beach may fall in; this is a serious erosion problem. Do not extract below the low water level because fish could become stranded and they will soon die.



Permission for extraction must be obtained from the Department of Fisheries and Oceans to ensure that fish habitat is not disturbed.

- **only extract from beaches when there is no other source**
- **obtain permission**
- x **do not extract below the low water level**
- x **do not extract in an active wave zone**

### Wildlife

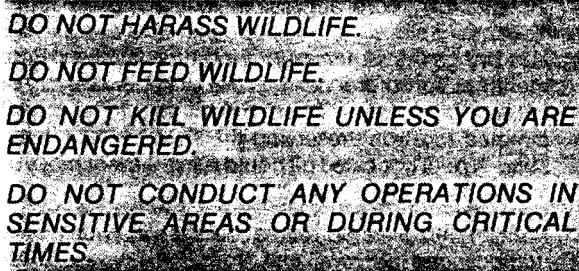

There are critical times in all wildlife cycles:

- |                              |   |        |
|------------------------------|---|--------|
| - nesting (waterfowl, birds) | } | Spring |
| - migrating (caribou)        |   |        |
| - calving (moose, caribou)   | } | Fall   |
| - rearing (all animals)      |   |        |
| - denning (bears)            |   |        |
| - staging (waterfowl)        |   |        |



These stages occur during the spring and fall. As a rule there should not be any pit operations planned at these times because of access and flooding problems associated with thaw and freeze-up. There are conditions however, limiting the operator if he does want to conduct any work during these times. The operator can be prohibited from using any machinery during given dates and/or in certain areas, so as not to disturb such activities as egg incubation and rearing of young.

Bears can cause problems if the camp or pit is not kept clean and free of garbage. If bears become a problem, the operator must report to the nearest Conservation Officer and use scare tactics. (fire a gun into the air, make loud noises) If a bear must be killed, it must be done as humanely as possible and the act reported immediately to the Conservation Officer.

If the operator conducts airborne field investigations, he must fly in straight lines between points and never go back for a second look at wildlife. Also, he must fly at an altitude of at least 500 metres over all wildlife areas.

Sandy or gravelly areas are often favoured by foxes and wolves for denning sites. Therefore, the site should be checked out.

Economically important fur-bearing species such as beaver and muskrat must not be disturbed because these animals are valuable to trappers.



source "The Caribou" by J P Kelsall 1968

- **machinery and airplanes can disturb wildlife**
- **bears must be reported**
- **scare tactics should be used against bears**
- **only kill bears if life or property is endangered**
- **fur-bearers must be protected**
- **avoid fox or wolf denning areas**
- x **do not conduct operations during critical wildlife seasons**

### Archaeological Sites and Monuments

**SURVEY MONUMENTS MUST NOT BE MOVED OR DAMAGED IN ANY WAY.**

**ALL OPERATIONS MUST BE A SPECIFIED DISTANCE FROM A KNOWN ARCHAEOLOGICAL SITE**

The past is our heritage, so it should be preserved. Therefore the operator is not allowed to conduct any land use operation in proximity to a known or suspected archaeological site or burial ground. Known sites are registered, so you had better check with the Inspector first when you are planning a pit.

- **check for registered sites**

Many archaeological and historical sites are unknown, so you may come across one in the course of your operations. If you do, then you must stop operations on the site and contact the Inspector at once,

- report any sites of historical significance that are found
- stop operations immediately

A survey monument is a fixed point which is used for surveying. Monuments must never be moved or knocked over, but if by accident they are, then they must be reported at once to the Surveyor-General. The Surveyor-General will also require payment for the investigation and restoration of the monument

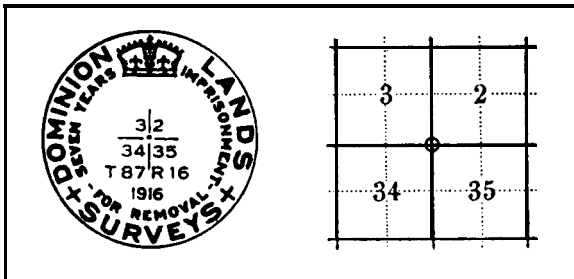

- report a moved or damaged monument
- pay for restoration of monument
- x never move a survey monument

### Recreation Areas & Viewpoints

**AVOID ALL PRESENT AND PLANNED RECREATION SITES.**

**DO NOT LOCATE PITS IN HIGHLY VISIBLE LOCATIONS.**

**DO NOT LOCATE PITS IN HEAVY PUBLIC USE AREAS.**

As more and more roads are built, the North becomes increasingly more accessible to the general public. Tourism can bring economic benefits to an area, but it also brings the requirement for tourist facilities. Part of the attraction of the north is the unspoilt scenery and natural landscape. Therefore all efforts should be directed towards preserving the scenery in its natural state. A poorly located pit could ruin a view or mess up a trophy fishing lake.

Present and planned recreation sites in your area are mapped and are available from the nearest DIAND office (see Appendix A).



- plan away from present and future recreation areas
- preserve the scenic resources

## Unique Geographical Features

**MACHINERY, VEHICLES AND EQUIPMENT ARE NOT ALLOWED WITHIN 150 METRES OF A PINGO.**

One of the unique features of permafrost is a pingo. A pingo is a round, hill-like feature as you can see in the picture below. This pingo at Tuktoyaktuk is probably the most well-known. Pingos are few in number, so the chances are that you will not encounter them in a pit operation. If you do wish to excavate in an area containing pingos, you are not allowed to move vehicles, machinery or equipment within 150 metres of the base of the pingo. The reason for this is that pingos are ice-cored, so if the vegetation is disturbed on them, rapid melting could occur and the pingo will eventually be destroyed.

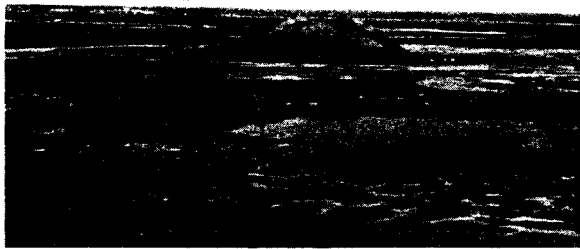

**x do not go near pingos with vehicles**

## Permafrost

Permafrost is a common feature of Northern environments and is a special problem for any land use operation, therefore it must be avoided if possible, Part 7 (Permafrost) has been set aside to look at the problems of operating a pit in permafrost,

**SCHEDULE**

|                   | SPRING                        | SUMMER                  | FALL                          | WINTER          |
|-------------------|-------------------------------|-------------------------|-------------------------------|-----------------|
| Ground conditions | - spring break-up             | - thawed ground         | - freeze-up                   | - frozen ground |
| Access            | no overland travel            | - summer travel         | no overland travel            | - winter roads  |
| Special problems  | - restricted use of equipment | - offset vehicle travel | - restricted use of equipment |                 |
| Wildlife cycle    | - critical wildlife           |                         | - critical wildlife period    |                 |
| Burning           | - burn bush                   | - fire season           | - fire season                 | - burn brush    |

The above chart shows how ground conditions, critical wildlife periods and the fire season combine to limit the seasons in which an operator may travel to operate a pit in isolated situations. While it is advisable to restrict travel during spring and fall because the environment may be damaged, it also makes sense practically not to travel during these seasons. The photographs in this section show that you can run into serious problems if you travel around at the wrong time of year.

Remember that you must have a permit to burn during the fire season, but you do not need one to burn out of the season.

- . travel at the right season
- . operate in the right season
- . burn in the right season

**Spring**

**OPERATIONS AND ACCESS MAY BE RESTRICTED.**

If you are planning a winter operation, you must make sure that you schedule your work to finish before spring break-up which marks the end of the winter road season. Operations may also be restricted during this time because spring is an important season for wildlife; loud noises can easily disturb the birds and animals. Stream crossings should be planned to avoid interfering with fish spawning and migration.

If you need to burn brush, this is the time to do it before the fire season starts.



- finish all winter operations before break-up
- . burn brush
- x do not operate in sensitive wildlife areas

**Summer**

**TRAVEL ON FIRM GROUND.**

**DO NOT BURN BRUSH AND SLASH.**

In northern regions, only the top few centimetres of ground may be thawed in the summer, often making the surface very wet. Travel in northern regions during summer can be difficult because the equipment sinks into the surface and serious rutting can occur (see Permafrost). The Inspector has the authority to stop all access if the rutting becomes too bad.

Overland travel further south does not present as much of a problem. The operator must keep clear from muskeg areas and stay on firm ground.

Summer is the fire season, so you can only burn brush if you have a permit.



- . avoid rutting by vehicles
- keep clear of muskeg
- . plan access in advance
- x do not bum brush

### Fall

**ONLY TRAVEL ON FROZEN GROUND.**

**OPERATIONS AND ACCESS MAY BE RESTRICTED.**

Fall is freeze-up time when some lakes and rivers freeze over faster than others. Any attempt at travel at this time before the ground is completely frozen can result in vehicles getting stuck in unfrozen terrain, therefore overland travel on wet ground is not advised.

The use of equipment may also be restricted in the fall if the operation is on or near a major waterfowl staging area or caribou migrating range. Crossings on streams may interfere with fish migration or spawning.

The fire season extends into the fall; burning of brush is only allowed by permit.



- avoid sensitive wildlife areas
- x do not travel until ground is frozen sufficiently to provide support
- x do not bum brush

### Winter

**OPTIMUM TIME FOR MOVING EQUIPMENT ACROSS LAND.**

In many areas, winter is the best season for overland travel because the frozen ground, with a minimum of 10-15 centimetres packed snow provides a hard surface for moving equipment and machinery. Road drainage is not a problem.

Although winter is the optimum time for access, the cold conditions and frozen ground may interfere with operations.

Brush may be burnt at this time.

- pack winter road properly
- good season for moving equipment
- brush burning time

## CAMPS

For most pits near communities, camps are not necessary, but for pit operations that do require a camp, a few basic rules must be followed.

### Location

#### USE EXISTING SITES IF POSSIBLE.

When possible the site of a previous camp should be used, so that additional land is not cleared unnecessarily,

#### LOCATE ON A FIRM SURFACE.

When there are no old camp sites available, the operator must locate the camp on gravel, sand or on a surface that can withstand heavy use. This guideline applies particularly to summer permafrost locations, where an improperly located camp can quickly become very muddy. Nevertheless, a camp should be properly located in all regions. In one of the photographs below, the camp is on a firm surface but the access to it has blocked the natural drainage causing erosion problems on the slope beneath the camp.



- camp on firm surface
- x access has blocked drainage



x flooding in permafrost

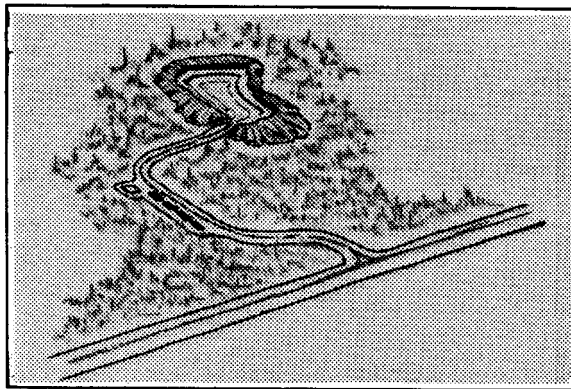

- . use existing camp sites if possible
- . use old access roads
- . locate on a good surface

### Garbage Disposal

#### DISPOSE OF ALL GARBAGE.

In every camp, all garbage and debris must be disposed of by: 1) removal from the site to an approved disposal site; 2) burning; or 3) burial. Garbage that is not disposed of properly attracts wildlife which can be harmful to the occupants of the camp and to the animals themselves. Until the garbage is removed or burned, it must be kept in a covered metal container,



- . all garbage must be disposed of properly
- . garbage must be kept in a covered container

### Removal

Garbage and debris must be removed from the site when the pit is located in special areas, such as bird sanctuaries, proposed parks, sites subjected to annual flooding. When the operator is asked to remove his garbage, all of it must be removed, even if it is burnt first to reduce its volume.

- total removal from site in special areas

### Burning

In small camps, a forced-air fuel-fired incinerator is not required, but the operator must burn all garbage and debris in a suitable container at least daily, to reduce any health hazard and discourage bears. In larger camps where at least 25 people are employed for three months or more, a forced-air, fuel-fired incinerator must be used for environmental and health reasons.

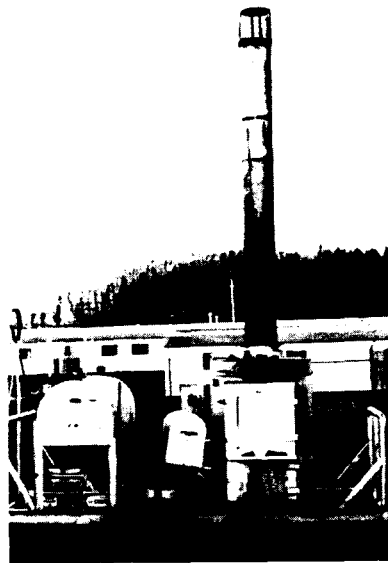

- . all garbage must be burnt daily
- . an incinerator is required in large camps

### Burial

**DO NOT BURY WASTES IN PERMAFROST.  
DO NOT BURY IN PIT.**

In most instances, burial is not allowed, but in some cases the inspector may approve burial of non-combustible material (scrap metal, discarded machinery and parts). Burial of debris should only be considered when it is impractical for the operator to remove the debris from the site. When non-combustible debris is buried, it should first be crushed and/or compacted and then buried below at least one metre of compacted soil.



- . only bury non-combustible material
- crush/compact before burial
- x do not bury in pit

## Sewage Disposal

Camps that stay in the same place for more than 15 days must deposit all sewage into a properly designed and located sump or lagoon. The sump must be large enough to hold all the sewage from the camp, and it must be covered in the interests of public health. The sump should also be located correctly downwind and downhill from the camp; downstream from the water source; away from water bodies. In the photograph, the sump is located at the top of the river bank, so that seepage through the sump is causing the river bank to collapse. This is a very poor location for a sump.

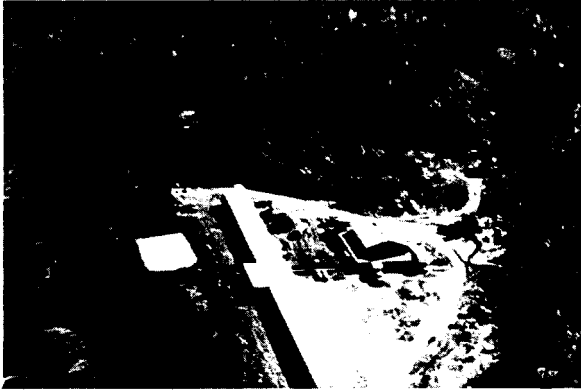

- . sumps required for stationary camps
- locate sump downwind and downhill
- x do not locate sump close to water bodies

Sumps and pits are not required in mobile camps (ones that move at least every 15 days) because more environmental damage occurs from digging a sump or pit than from the small amount of sewage generated from the camp.

## Fire Fighting

Fire fighting equipment must be present in camps in forested areas during the fire season. in camps of 5 men or less, there must be 2 back-pack bags or cans complete with pumps and at least one pulaski, axe and shovel. In largercamps (more than 5 men) 4 back-pack bags are required and at least two pulaskis, axes and shovels.

It is important to maintain fire fighting equipment in camp for your own protection. If you do cause a fire and do not have any fire fighting equipment, you will then be liable to pay any fire-fighting costs.



# Part 4

## Design - Pits

### GENERAL LAY-OUT

To develop a pit in an orderly and efficient manner, it must first be well designed. This is the time to decide how you are going to lay-out the area so as to eliminate problems throughout the operation and make restoration easier.

Remember that boundary edges are the absolute limits of the excavation - all work, including stockpiling and restoration must take place within these limits. Therefore, a well designed pit will allow for

- controlled access in and out of the pit
- working space in which to move equipment
- storage areas for stockpiling topsoil and overburden separately
- space to form a final grade
- visual screening

Legend:

- 1 Dogleg access
- 2 Buffer Strip
- 3 Flagged Boundary Line
- 4 Edge of clearing
- 5 Topsoil pile
- 6 Overburden pile
- 7 Working space
- 8 Pit floor

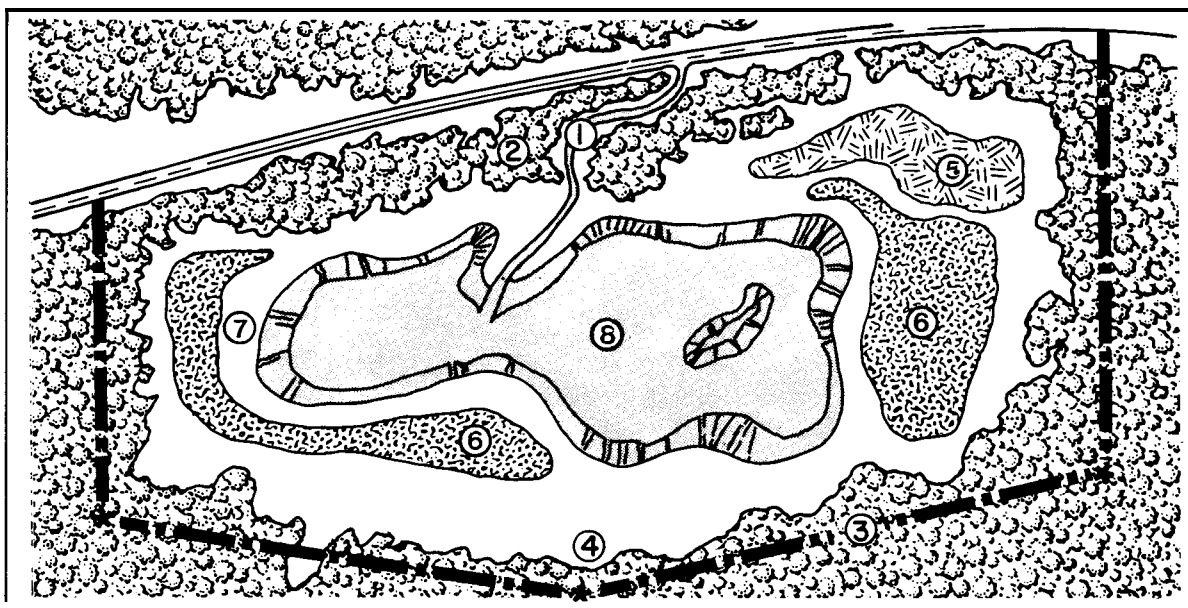

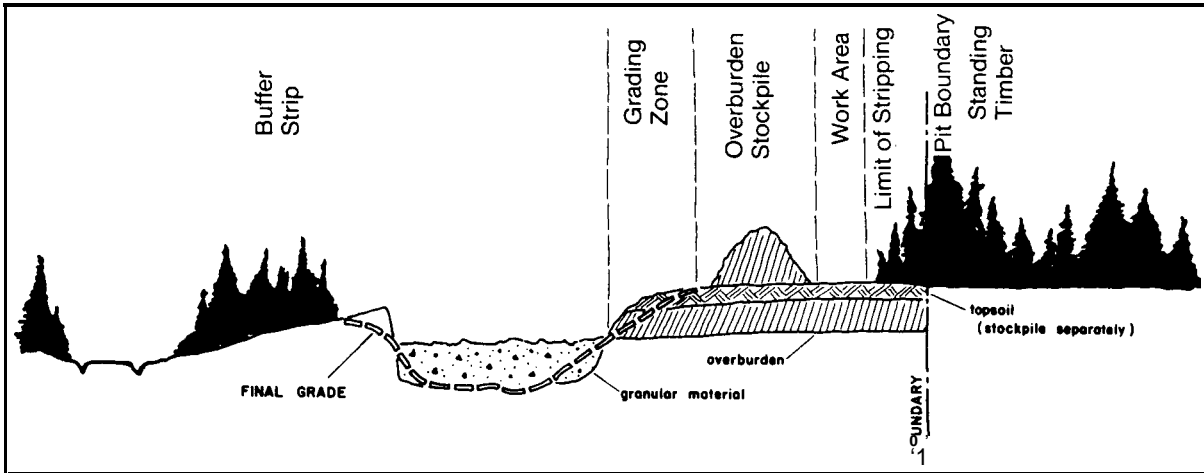

## CONTOURING

### CONTOUR THE PIT

Before work areas and stockpile sites can be defined, the operator must decide on the shape of the pit and the pit boundaries.

On flat land, contouring may seem impractical, but at the restoration stage you will find that a pit with irregularly shaped edges will look more acceptable and be easier to landscape than one that is square or rectangular in shape. However, if the pit is on the side of a hill, you must try to blend the pit boundaries into the natural landscape so that it follows the pattern of the land and looks like a natural opening. A pit with rounded edges with varying depth is more acceptable, especially when the pit is located along a roadway. On major highways, a landscape architect is often required to design roadside borrow areas,

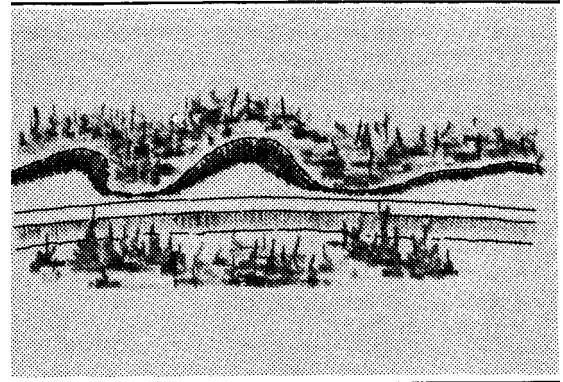

• good practice

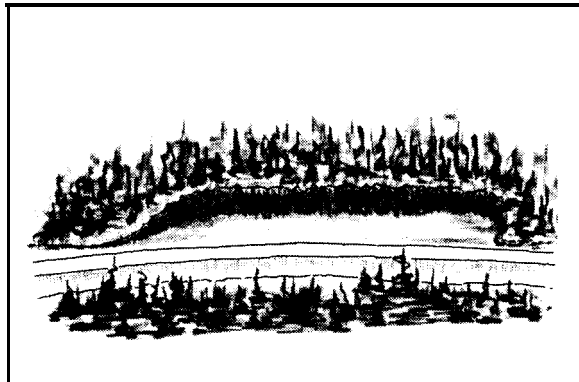

x poor practice

- blend ends of cuts into landscape
- blend roadside borrows into existing grades

Where cut and fill is ongoing, it may be better to remove additional material from the cut area rather than open up a new pit. In this case, extend the cut along the inside corner and provide for drainage control on steep slopes,

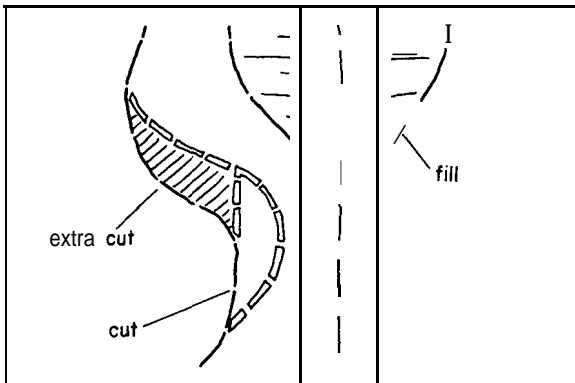

- . take more material from cut rather than open new pit
- . extend cut along inside corner

### STAKING

#### THE PIT BOUNDARY MUST BE STAKED

The best protection that can be given to the environment is to limit the amount of land that is disturbed. Staking and flagging the development boundary is the first and most important step in containing your work activities.

Staking is the process by which your design becomes effective. The lay-out designed on paper now becomes an actual lay-out on the site.

- . staking is the first thing to do on the site
- control points should be set up

### PLACEMENT OF SURFACE MATERIAL

#### Windrow or Slash Location

Dispose of all slash. If it is not possible to dispose of slash immediately, it should be placed in a compact windrow and at least 5 metres away from standing timber to reduce the hazard of fire.

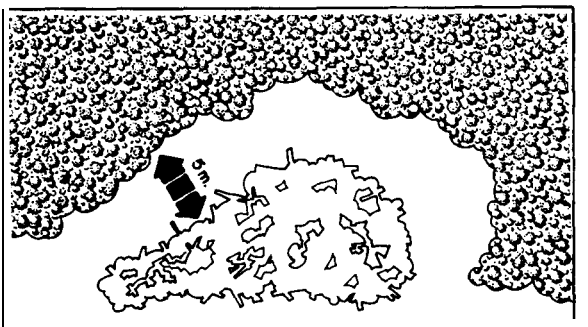

- . compact the windrow
- locate 5 m from standing timber
- x do not locate windrow in standing timber

### Topsoil

#### ANY TOPSOIL MUST BE SAVED

All organic soil must be stripped from the cleared area and saved for restoration purposes. Topsoil must be piled in its own separate location and must not be mixed with the overburden. Make sure that there is ample working space behind the pile to allow equipment to re-spread the material at the restoration stage,

- . all organic topsoil must be saved
- . stockpile separately from inorganic overburden
- allow working space behind stockpile

### Overburden

#### STOCKPILE OVERBURDEN SEPARATELY

When there is only a thin layer of overburden, it should be stockpiled around the pit with a working space behind it of at least 5 metres from standing timber.

A space should be left between the overburden stockpile and the leading edge of the pit in order to allow equipment to achieve a pit slope which **comes up to** ground level before the overburden is pushed back.

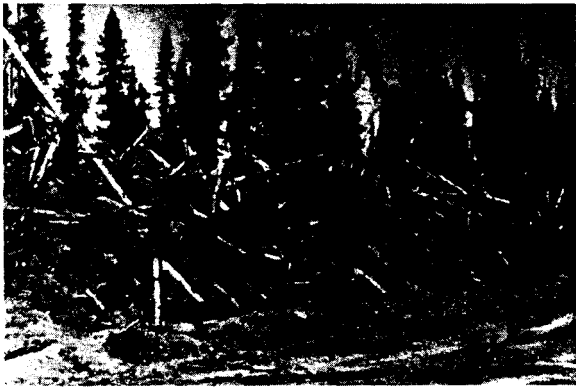

- x do not mix overburden with slash
- x do not push overburden into standing timber



- overburden must be stockpiled with working space behind and in front

In cases where there is an excess of overburden or "cut waste" it may be necessary to remove it to a new disposal site. Make sure that the stockpiled material is on well-drained ground and away from any water bodies. It should not be located in a well vegetated area. Once hauled to an adjacent area, it should be dumped in small heaps, contoured and graded into a low profile,



- . dump overburden into small heaps

#### Stockpile Location

**SAVE MATERIAL SEPARATELY  
STABILIZE SLOPES**

Excavated material should be stockpiled on well-drained ground close to the haul road. Allowance must be made for easy movement in and around the supply. Make sure the slopes are stable and do not allow granular material to mix with overburden or topsoil,



- . stockpile on well-drained ground
- allow for access to stockpile



**x poor practice**

- x make sure the stockpile has stable slopes**
- . keep separate from overburden and topsoil**

If the material is ice-rich and a lot of flow is expected on melting, provide for drainage.

## **VISUAL SCREENING**

### **SCREEN PIT WHERE POSSIBLE**

It is a good idea to 'hide' an open pit from view if at all possible.

An ideal situation is to develop the pit on the downhill side of the road where it is completely concealed from view.

Visual screening can be done in a well vegetated area by leaving a buffer strip of dense, wind firm trees 30 metres thick between the road and pit. If a pit is near a water course, it is especially important to leave a wide buffer zone ( 100 metres) of standing timber, as the natural vegetation serves to filter run-off and protect fish.

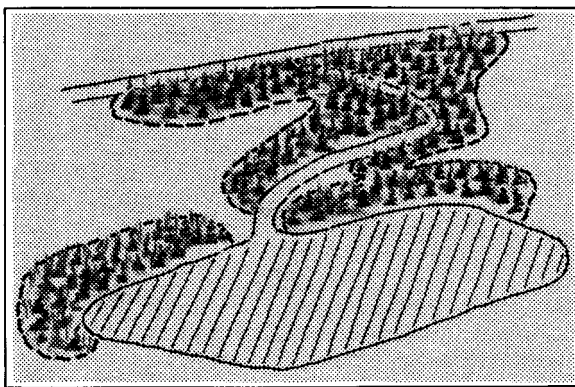

There are some cases in which leaving a buffer strip becomes more of a hazard than a benefit and should then be removed:

- x -if the strip runs at right angles to prevailing winds (susceptible to blowdown)
- x -if the strip runs directly east-west and the highway is north of the strip (the trees will block the sun, prevent melting and form black ice on the surface)
- x -if the stand is thin or sparsely vegetated, very old, or diseased (it may not be anchored well enough)
- x -if the pit is adjacent to another clearing such as a pipeline right-of-way, relocated roadway or power line (it becomes too thin)
- x -where an entrance and exit are being used, a strip of trees results in a small 'island' of vegetation (this is inadequate)



**x excessive clearing next to road**

Highways are sometimes located directly on top of the best granular material deposits because well-drained road material is already available at its base, without hauling in new material from other areas. If the source lies within 50 metres on either side of the roadway, leaving a 30 metre buffer strip would make the source unavailable and require further excavation elsewhere. In this case alone, a buffer zone of trees will not be required and widening of the right-of-way and extending the view is a more acceptable practice, if proper contouring and ditching takes place. If visual screening is required, it can be achieved by building a berm along the road side of the pit edge.



- berm on side of road screens pit from view
- buffer zone of trees must be 30 m thick
- a buffer zone is not required when
  - it is susceptible to blow-down
  - it shades the road
  - it is too thin
  - it covers needed granular material

### ACCESS ROADS

An access road is needed to get to most pits, therefore attention must be given to some of the basic procedures for building an environmentally acceptable access road. Details on design, grade, culvert installation may be found elsewhere (see Appendix B).

#### Summer and All-weather Access

##### DOGLEG ACCESS ROAD

In addition to screening the pit with a buffer zone, the pit access road and/or the pit itself can be hidden by doglegging the access approach to the highway.



- dogleg access
- minimize clearing on right-of-way

Y-shaped approaches to the highway and separate entry and exit roads from the pit are not acceptable since both require additional clearing.

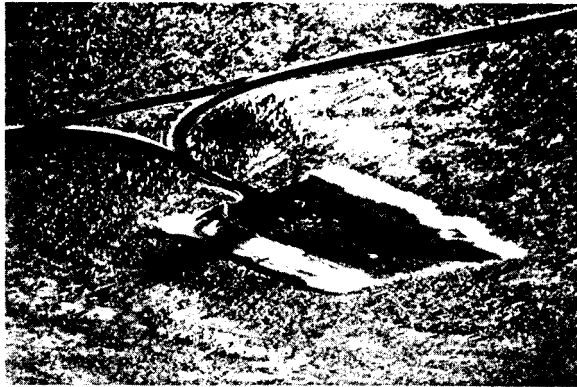

x poor practice

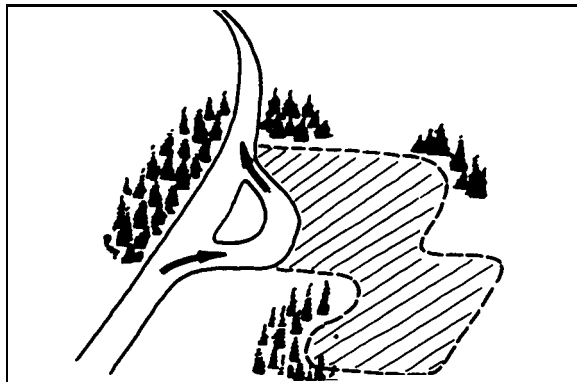

x poor practice

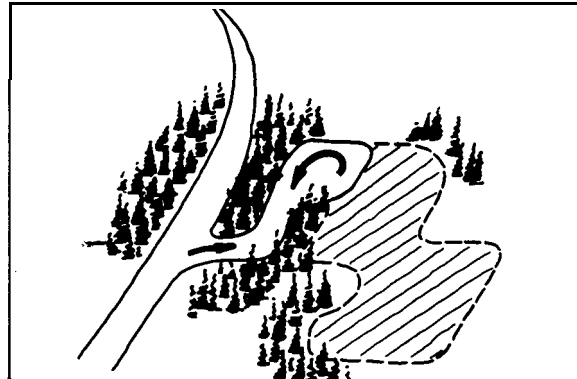

- single entry access is preferable
- turn vehicles in pit

The right-of-way width should be kept to a maximum of 10 metres. Access to sites that are left open for future use, must be maintained in good condition. If erosion is likely to become a problem, it is a good idea to spread some of the cleared slash over the right-of-way.

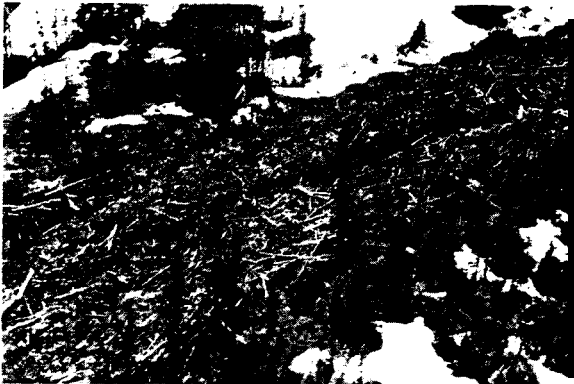

- maintain roads if needed for re-use
- slash on road prevents rutting and erosion

Access roads that are to be permanently abandoned and closed off from public use should be rescreened from view and cross-ditched. Screening may be accomplished by placing boulders, transplanting trees or shrubs, or by building a berm. Cross-ditching prohibits vehicle passage and allows for more natural surface drainage.

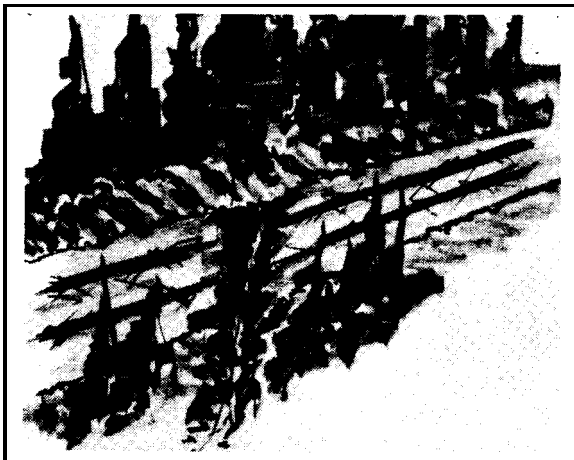

- cross ditch permanently abandoned roads
- block access

### Winter Roads

Winter roads must not be used until the ground is sufficiently frozen to support equipment and there is compacted snow depth of at least 10-15 centimetres on the surface.

### STREAM CROSSINGS

**NEVER DISRUPT, IMPEDE OR BLOCK FISH MOVEMENT.  
LIMIT NUMBER OF STREAM CROSSINGS.**

in crossing any stream or river the possibility exists of disrupting fish passage and spawning, and causing siltation or erosion, therefore it is strongly advised that the number of stream crossings needed for an access road be limited to the absolutely essential ones.

There are four ways of crossing streams; which method you choose depends on the time of year, the size of the crossing and the number of fish in the stream:

- culvert installation
- bridge construction
- fording.
- ice bridge construction

Any stream crossing however, must be approached at an angle and the water must be crossed at a right angle, (the shortest distance).

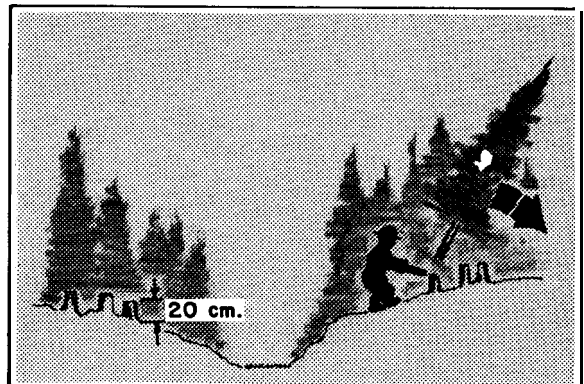
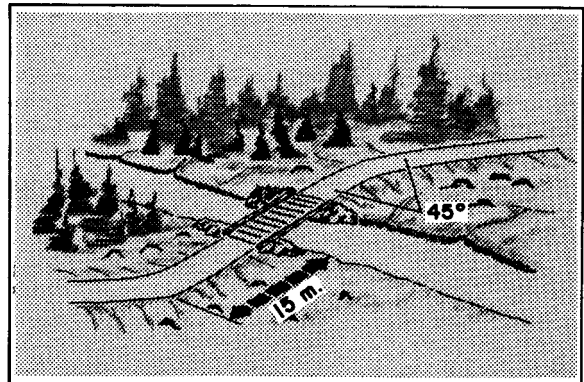

- doglegged approach
- cross at 90°
- hand clear near streams
- fell trees away from stream

### Culvert Initiation

Culverts must be adequately sized and properly installed.

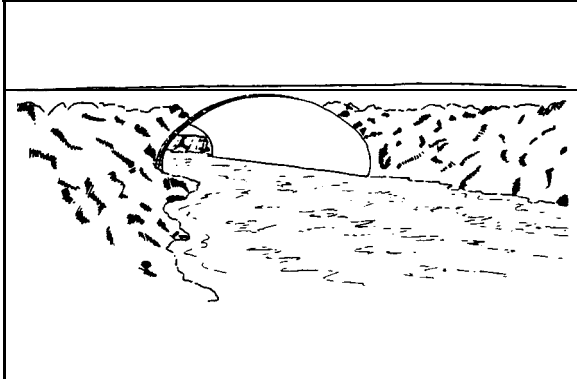

- good placement
- proper size

The culvert must be large enough to accommodate peak flows (spring run-off). Culverts that are too small result in ponding beside the roadway, or roadway collapse.



- x culvert too small
- x ponding beside road

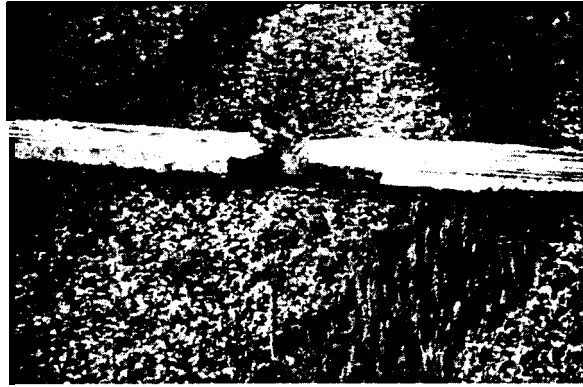

- x no culvert
- x too late
- x roadway collapse

Increased currents due to channel constriction can seriously hinder fish passage, therefore the Department of Fisheries and Oceans should be consulted on correct sizing. Also, make sure that the bottom of the culvert does not interrupt the natural contour of the stream bed, because a 'step' in the profile can impede fish movement,

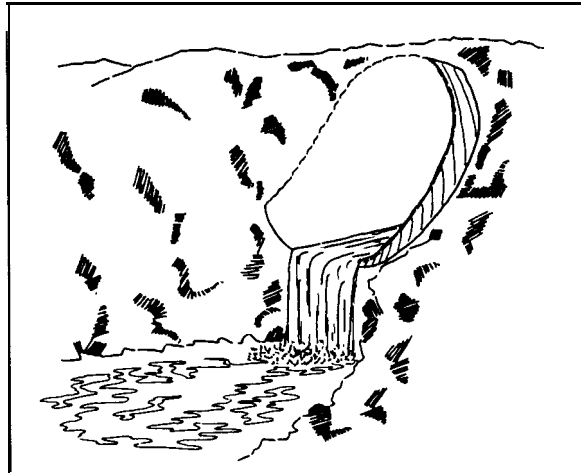

- x poor practice
- x 'step' impedes fish movement



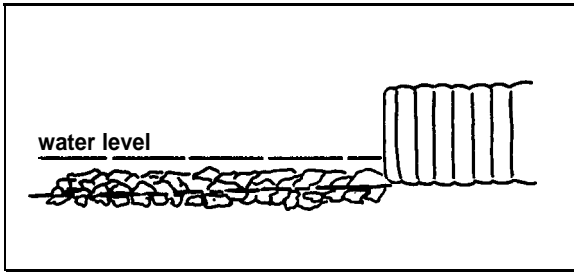

- good practice
- contour of stream maintained
- culvert placed below stream bed

The surrounding embankments and stream channel must be protected with rip rap,

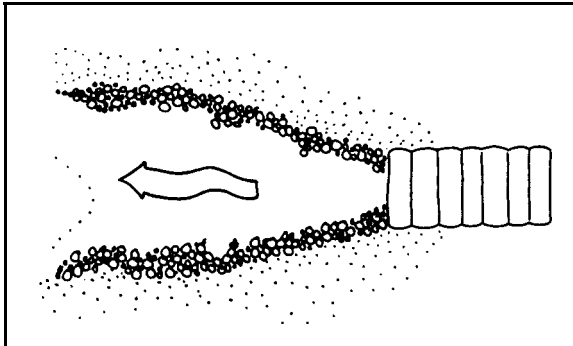

- proper placement of rip rap for culvert

## Bridges

### LARGE RIVERS SHOULD BE AVOIDED

Many pits are reasonably close to a major roadway therefore existing river crossings using bridges should be used before construction of a new bridge is considered. If a bridge is required, the Inspector and an engineer must be consulted.

For temporary crossings, portable bridges are recommended, but the span length of these structures is limited. Another method of crossing relatively narrow wet areas or indeterminate streams is to build a timber bridge crossing as shown below. This must be removed on completion of the pit operation.

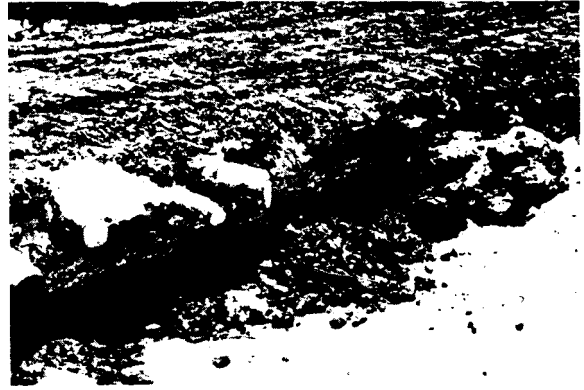

- timber crossing

## Fording

Fording is allowed but it may be limited or stopped at any time by the Inspector. Although not favoured, corduroy roads may be used in small streams to reduce siltation from frequent fording, but they must be removed before freeze-up.

## Ice Bridges

Ice bridges should be located where the stream banks are low to reduce the size and number of ramps.

Ice bridges may be constructed using only snowfall, but sometimes limbed trees may be allowed, but they must be completely removed before spring break-up. The use of slash and dirt is prohibited. In streams that do not normally freeze to the bottom, a free-flowing channel should remain to allow for movement,



- all debris must be moved before spring break-up

# Part 5

## Operations - Pits

When you read this section, you will by now have planned where your pit will be, and have found out how to design it properly. Remember that the Planning and Design chapters must be read before you read this chapter on how to operate the pit.

The first stage is to prepare the site

### PREPARATION OF SITE

The site is prepared for excavation by doing the following:

- brush clearance/slash removal
- grubbing
- overburden removal

### Brush Clearance/Slash Removal

**ALL BRUSH AND TREES MUST BE REMOVED**

**CLEAR MINIMUM AREA**

Before the topsoil and/or overburden can be removed, brush and trees must be cleared from the pit site. Only the minimum area necessary for the operation of the pit should be cleared.

To assist the bulldozer operators in clearing, the boundaries of the pit, the access road and the buffer zone should be clearly flagged so that unnecessary clearance does not occur. Inspectors should be on hand when clearing commences.

In some areas where there are trees being cleared that are larger than 12 centimeters across, and they are considered to be valuable, then they should be saved,

Refer to the terms and conditions on your permit for saving and stacking merchantable timber.

### Machine Clearing

**DO NOT DAMAGE SURROUNDING VEGETATION**

For general clearing, machinery may be used. Trees should be cut flush with the ground, unless clearing takes place when there is snow cover. When there is snow on the ground, the vegetation cannot be cut to ground level and therefore the stumps must be removed the next summer

Machinery operators must be careful not to damage the vegetation that surrounds the pit site, therefore it is best if the trees around the edge of the site are felled in towards the cleared area. Trees should not be left at an angle around the edge; these are called 'leaners' and should be felled.

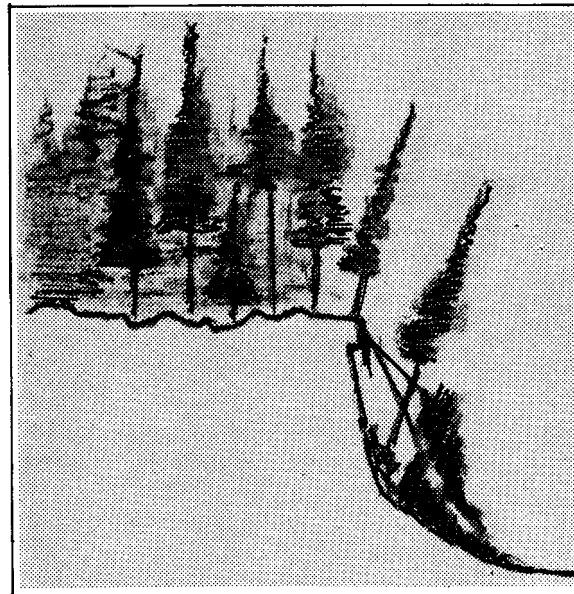

x poor practice



x poor practice



- good practice
- clear away from pit edge
- fell trees inwards
- use proper equipment
- x do not damage surrounding vegetation
- x do not leave 'leaners'

Once the brush and trees have been cleared, the operator can do one of three things:

1. windrow material and save for restoration or
2. pile and burn brush and slash completely or
3. use a chipper

windrow

#### LEAVE SPACE AROUND WINDROW

Windrowed material should be placed along one side of the pit with a space of at least 5 metres between the windrow and the standing timber to minimize fire hazard and allow machinery to move behind it at the restoration stage. The windrow should be well compacted.



- x poor practice
- leave a space behind windrow
- compact windrow

## Burn Slash

### BURN ALL SLASH

If slash is not required for restoration purposes, it should be piled and burned in a controlled manner before the fire season begins.



burn before the fire season

## Chipper

### WOOD CHIPS MAY BE USED FOR INSULATION

The use of a chipper is a good way to dispose of slash but a chipper is expensive, it makes a lot of noise and there is some doubt as to whether a layer of wood chips on the cut surfaces of a pit aids or slows down the revegetation process. On the other hand, wood chips act as a good insulator on slopes that are susceptible to thawing

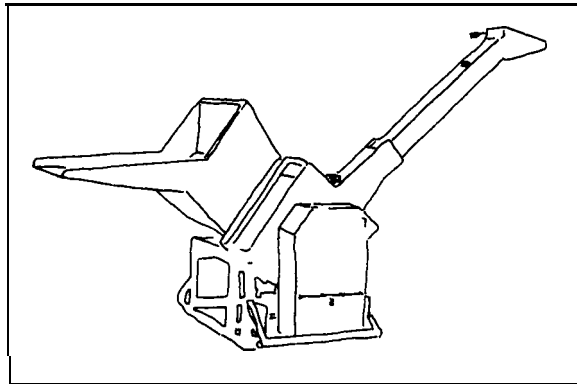

## Grubbing

**REMOVE ALL LARGE ROOTS AND STUMPS FROM SOIL**

Grubbing is required to remove large tree trunks and roots from the soil. The soil cannot be frozen for this operation, so grubbing must be done in the summer.

If any areas are mistakenly grubbed, the operator must spread slash material over the disturbed area.

- grubbing must be done in summer

## Removal of Overburden

**REMOVE TOPSOIL AND SAVE SEPARATELY**  
**REMOVE OVERBURDEN AND SAVE SEPARATELY**

After the brush is removed, the unsuitable soil and stone (overburden) above the granular material must be stripped off,

Overburden removal should be in 2 stages:

1. removal of the organic layer (top soil and muskeg)
2. removal of the inorganic layer (overburden)



. overburden and topsoil removed separately

In many areas of the Northwest Territories and Yukon, there is little or no top soil making removal of the organic layer impractical. However, where there is a well-defined organic layer, it should be removed and saved away from the rest of the overburden to prevent mixing (see Design).

The depth of overburden varies from place to place from a few centimetres to several metres, but however thick, it must be saved for pit restoration. The location for piling overburden was discussed in Design. The overburden piles should be sloped, rounded or oblong and must be located on a well-drained site away from streams and lakes.



- . always save available topsoil
- . always save overburden
- x never mix topsoil and overburden
- x never pile overburden in trees

## METHOD OF EXCAVATION

### Depth of Pit

All excavation must ideally take place above the maximum water table level except in permafrost (see Permafrost). The water table varies from season to season, and year to year. A dry pit one year could turn into a flooded pit the next year, and it will then have to be drained before any more material can be extracted. You must make sure therefore, that you excavate at least 0.5 to 1 metre above the water table level.

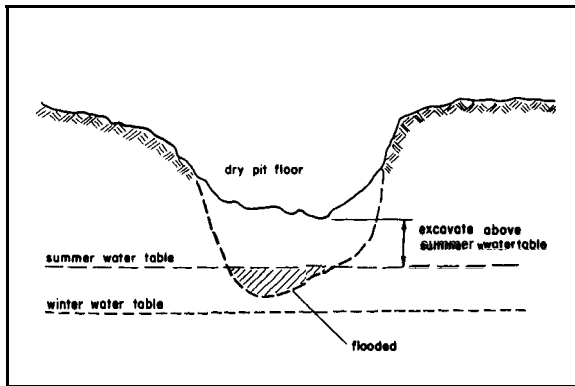

- always excavate above the water table

### Slope of Side Walls

In all areas but the continuous permafrost zone, the tops of excavated slopes should be rounded to reduce the likelihood of slumping. In loose material, the vertical cut face should not exceed 3 metres for safety reasons. A slope should never be undercut in order to obtain material. Special procedures apply in continuous permafrost, so the reader is advised to read Part 7 on permafrost.

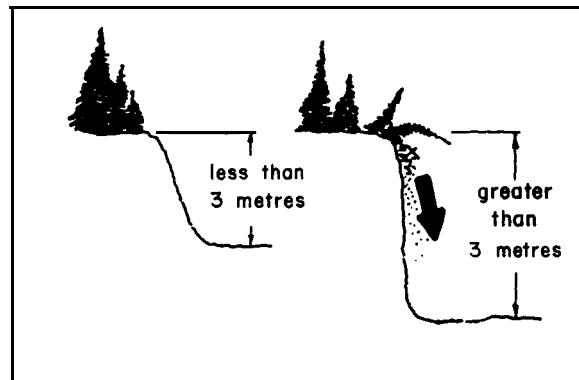

- round the tops of slopes
- side walls should be less than 3m
- x do not undercut slopes

## SEQUENCE OF EXTRACTION

Granular material is a non-renewable resource and therefore every effort must be made to extract it carefully. The operator should think about the order, or sequence in which he will extract granular material from a site. A distinction must be drawn between single user pits and multiple user pits.

### Single User Pits

In small, short-term (less than one year) pits, such as highway borrow pits, the whole site may be opened up at once (slash removal, grubbing, topsoil and overburden removal). The granular material is then extracted all at one time.

In larger, long-term (more than one year) pits, the operator should plan to extract sections of the pit sequentially, on a year-to-year basis. In this way, no section of the pit is cleared until the year in which the material is needed.

When only one section (the one being worked) is kept open at a time, the operator will have a tidy and controlled operation. The following shows a possible sequence of operations:

The following is a typical operating plan for a single user pit operated for more than one year. The numbered arrows show the order in which things are done.

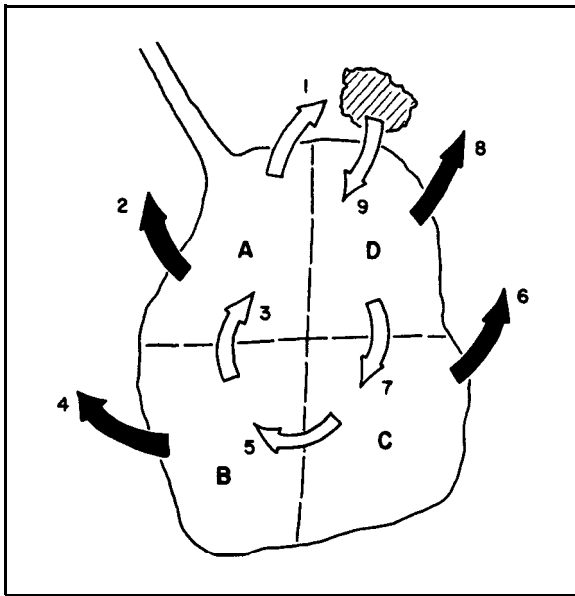

A will be opened up first

- slash removed
- 1) - overburden is removed to a location near D
- 2) - granular material is removed from A

B will be opened next

- slash is removed
- 3) - overburden from B is used to restore A
- 4) - granular material is removed from B

C

- slash is removed
- 5) - overburden from C is used to restore B
- 6) - granular material is removed from C

D

- slash is removed
- 7) - overburden from D is used to restore C
- 8) - granular material is removed from D

#### Final Restoration

- 9) - the overburden originally moved from A is now used to restore D

N. B.- The topsoil should have been saved separately and should now be used to 'dress' the whole site



. develop the pit in sequence

There are several advantages to developing a pit sequentially rather than haphazardly:

- avoids unnecessary clearance of vegetation
- avoids problems of leaving stockpile sites and working area between surrounding vegetation and the pit edge, except for original movement of overburden from A (Step 1)
- allows maximum extraction of material from site
- limits the amount of earthmoving
- can do restoration as you go along

The above example is for one shape of pit and a 4-year operation; site development will vary with different shapes of pits and with the size and length of your operation. Some alternatives are shown. Remember that this type of development is only recommended for operations lasting more than one year. Special problems associated with permafrost are dealt with in Part 7.

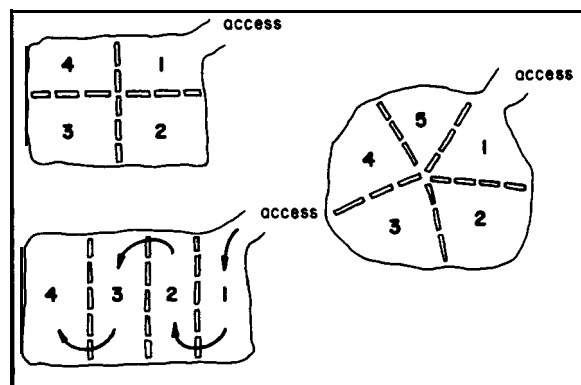

### Multiple User Pits

When there are a number of different users, a careful site development plan must be drawn up so that each operator can extract his required amount of material and stockpile it, without interference from anybody else. It is also important that the material is not wasted due to unsupervised extraction procedures.

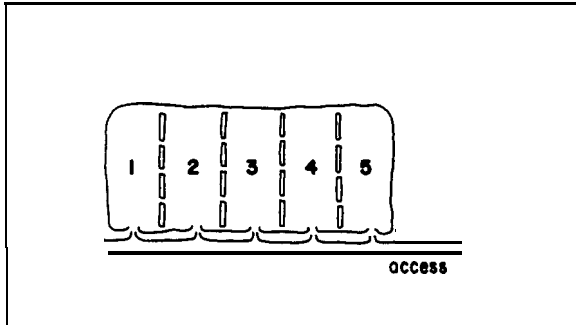

. possible site development plan in a multiple user pit

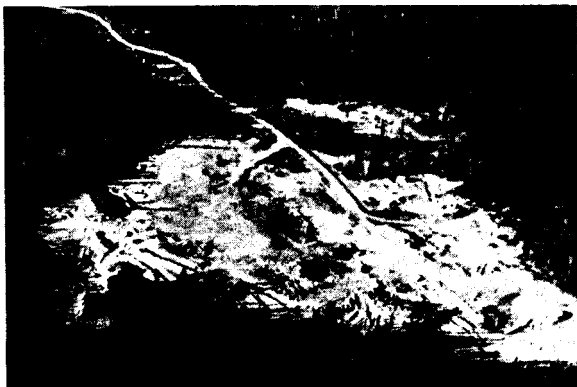

x random excavation in multiple user pit

### SCREENING AND CRUSHING OPERATION

Crushing and screening equipment and the stockpiled material must be located in an easily accessible position in the pit to allow access from the cut face and to the access road for haulage. Because the area around the crusher is a heavily used area, it must be located on well drained and durable (hard) ground.

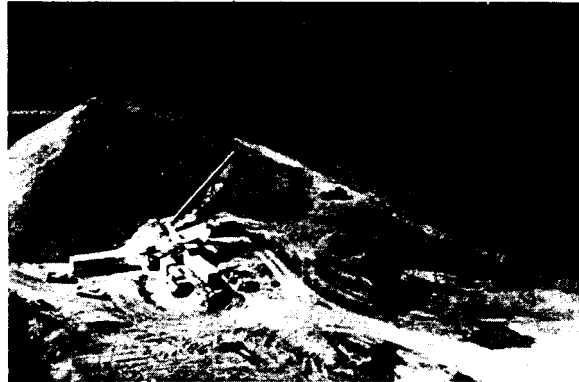

- easy access to stockpile
- located on hard ground

The time of year is important in crushing because when the particles are frozen they form clumps and stick together. These clumps will not pass through the grizzly screen and good material is wasted. Any clumps or rocks up to 20 centimetres in diameter should be processed through a primary crusher to obtain the optimum amount of fractured surfaces. This will improve the quality of material and reduce the amount of waste. Otherwise, it is advisable to use well dried out material.

Dry material can cause problems though because of the dust stirred up by the operation. All parts of a permanent or day camp should be located away from the crusher to protect the health of the employees.

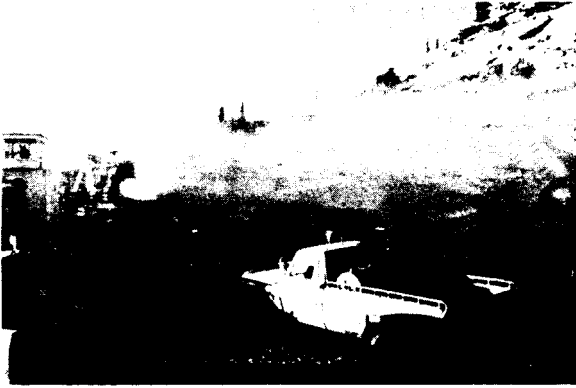

- x excess dust causes health problems
- . locate all parts of camp away from crusher

Different sizes of crushed material are obtained when the material is passed through different size screens. Screened materials are stockpiled separately.

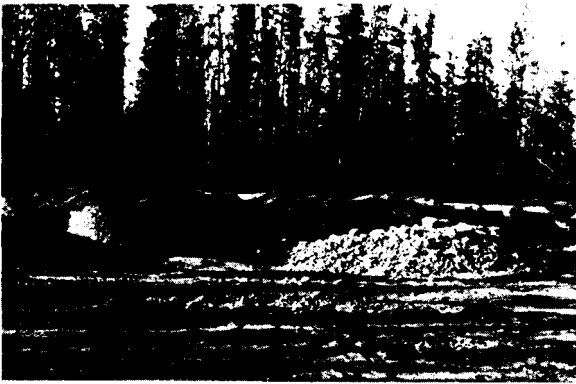

- . different mixes of material for different uses

## **DRAINAGE AND EROSION CONTROL**

The pit should have been designed so that the problems of flooding and erosion are reduced. However, if flooding or erosion do occur, the operator should know about some control measures.



- x flooding reduces efficiency of operation

### **Drainage**

No part of the pit operation (camp, access, overburden, stockpile) should be located so that it obstructs natural drainage and causes flooding or channel diversion.

If flooding does occur in the pit itself, the operator has a choice of what to do

- use a pump
- cut drainage ditches

When a pump is used, the operator must make sure that the pumped water is not released at the top of a slope; it is better practice to extend the pipe so that the outlet of water is onto level ground or directly into a stream or river.

Drainage ditches may be used within the pit to drain small amounts of water away from the working area.





- cut small drainage ditches in pit

Larger ditches may be cut through the pit walls, but it is best to cut more than one so that the outflow of water is not concentrated into one place. The drainage channels must be located so that the outflow is not down a steep slope or towards any structures or roads.

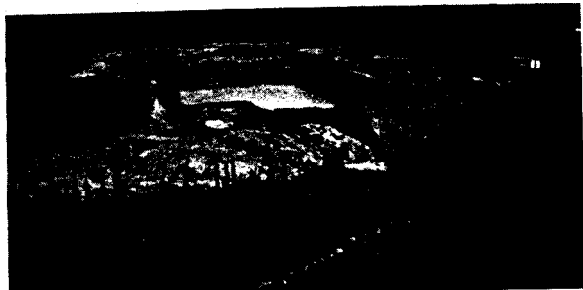

- . cut more than one ditch
- x do not drain water towards any line, road or structure

When improper drainage procedures are used (pipe outlets at top of slope, drainage ditches poorly located), **erosion** occurs. There are a couple of ways to slow down erosion and minimize its effects:

- spread slash on the eroding slope to slow down runoff;
- cut shallow benches on the slope which also slows down runoff.

The photographs below show an example of lake siltation and loss of vegetative cover as a result of poor drainage procedures. Slash has been used on the slope to slow down any further erosion.

## Erosion

Erosion may result from 2 things:

- improper drainage procedures
- wrong slope angles



- x pipe outlet at top of slope causes severe erosion of slope



- x rapid flow removed all vegetation
- x eroded material silted up water at foot of slope



. slash used to reduce further erosion

The operator must ensure that the pit walls or stockpiles are at the correct slope for loose material. Heavy rainfall or natural runoff on steep slopes can soon wash all the material down the slope and into the working area. This is not good for the efficient operation of a pit.

### EQUIPMENT SERVICING

Every pit operation uses equipment, however, no equipment operators should use the pit site as a disposal place for oil, oil cans, fuel containers and so on. When engine oil is changed, it must be reclaimed or burned so that it does not pollute the soil or water and destroy the vegetation.

### Fuel Storage

A small fuel cache (less than 4,000 litres or any one container with a capacity of less than 1,000 litres) must not be located within 12 metres of the normal high water level of any streams, but it does not require dyking. Any larger fuel caches must have an impermeable dyke. All fuel containers must be properly sealed and stacked in an upright position to prevent the possibility of spills and leaks.

- store fuel properly
- locate fuel more than 12 m. from water course
- prevent leaks and spills

### Chemical and Petroleum Spills

Any spills of chemicals or petroleum must be reported immediately to the Inspector.

It is important that all spills are reported in order to protect domestic water supply, fish, wildlife, vegetation and soil.

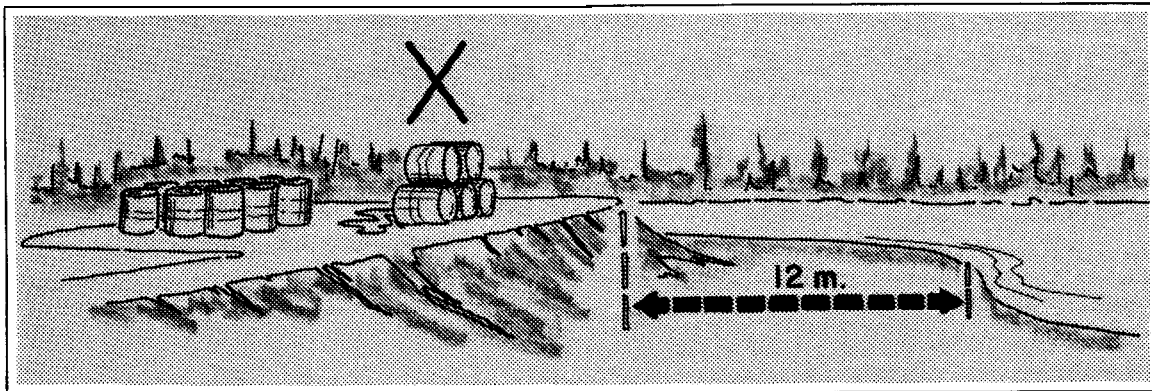

# Part 6

## Restoration - Pits

### ALL PITS MUST BE RESTORED

At all stages of the pit operation that have been discussed so far (Planning, Design and Operations) methods that make final pit restoration easier have been stressed. Wherever a pit is located and however small or large, it must be restored in some way.

### FUTURE PUBLIC USE

#### CHECK FUTURE USE OF SITE

Before restoration begins, the operator should consult with the Inspector about the possible future use of the pit site. Possible uses include: picnic or camping areas, scenic viewpoints beside the highway or as a waste disposal site for community use. In all cases the granular materials must be completely removed before restoration takes place. If the pit is to be landscaped or used as a landfill site, the operator may turn the responsibility of pit restoration over to the government.



• scenic overlook

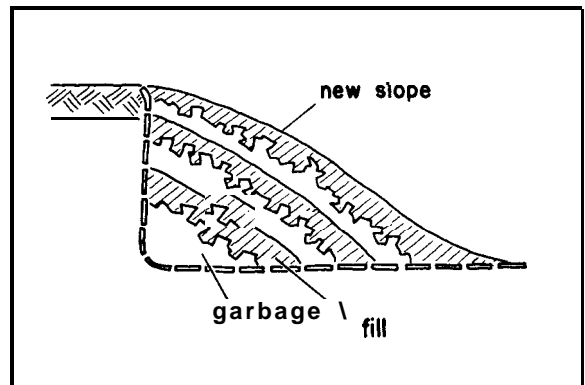
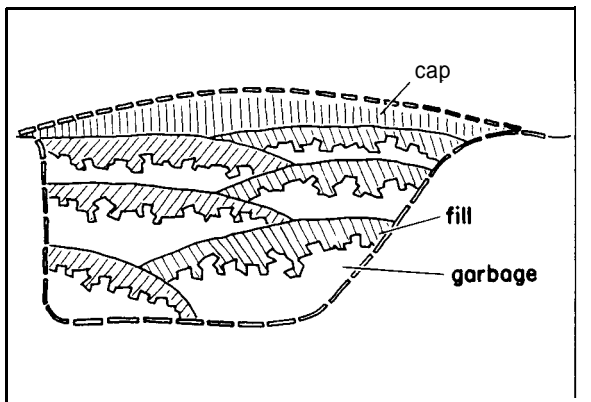

When no future public use is planned for the pit site, then the operator must restore the pit so that it will blend in with the local landscape and vegetation.

### DISTINGUISH BETWEEN TEMPORARY AND COMPLETE ABANDONMENT

Restoration requirements vary depending on whether the pit is being abandoned permanently or only temporarily.

The pit is temporarily abandoned when it still contains usable material. If this is the case, the working face of the pit should be left open for future operators.

Restoration steps to be taken for temporary abandonment include:

- clean up
- drainage and erosion control

Clean-up and drainage and erosion control are also required for complete abandonment together with:

- recontouring
- overburden replacement
- revegetation

## CLEAN-UP

Although the pit and surrounding areas should be kept as clean as possible throughout the operation, any garbage or debris must be completely disposed of before leaving the pit (see Planning). All buildings, machinery and fuel containers must be removed unless the operator has written permission from the Inspector to leave them there for future use on site.



- x unacceptable
- complete clean-up
- remove all buildings, machinery
- only leave buildings, machinery with written permission

## DRAINAGE AND EROSION CONTROL

If abandonment of the pit is temporary, access to the remaining material must be assured, therefore if the pit is likely to flood, drainage control measures should be taken by pumping or cutting drainage ditches (see Operations).

- x pending hinders access to remaining material

Wherever possible, revegetation of a completely abandoned pit should be considered, but in northern areas where revegetative growth is very slow, it is acceptable to let the pit flood naturally.



- flooding acceptable where no vegetation planned

When revegetation is possible, adequate drainage control measures must be taken.

Erosion should not be a problem in a properly contoured pit where the slopes have been rounded, do not exceed an angle of 2:1 and are stepped where necessary, (see next section). Nevertheless, there are a few additional erosion control measures that should be considered:

1. the construction of a berm at the top of the slope to stop water from running into the pit;
2. lay brush and slash across the slope to slow runoff and hold back sediment;
3. direct runoff to bottom of slope through a drain pipe.

## RECONTOURING

### RECONTOUR PIT SLOPES

When the pit is totally abandoned, the slopes of the pit should be graded to a slope no steeper than two horizontal to one vertical (2:1).

A combination of waste granular material and cut and fill (see diagrams) should be used to achieve a nicely recontoured pit.

The final shape of the pit should blend into the natural contour of the land. This means that the recontoured slopes should be rounded outwards, rather than hollowed out or left vertically with sharp edges. If the pit walls are high, the recontoured slope should be gently stepped to help reduce erosion.



• well contoured



• good practice



x has not been contoured



x poor practice

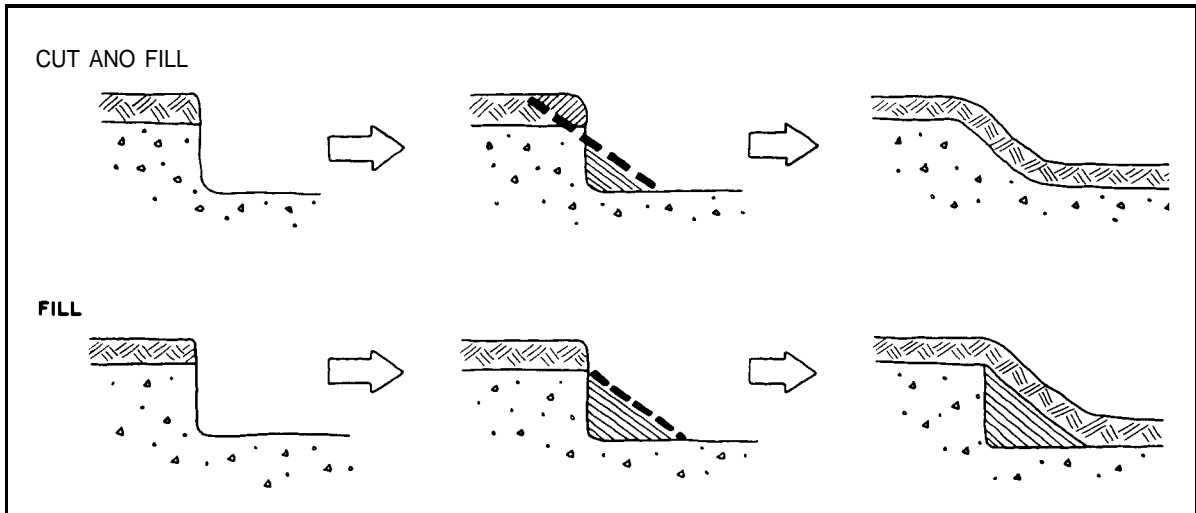

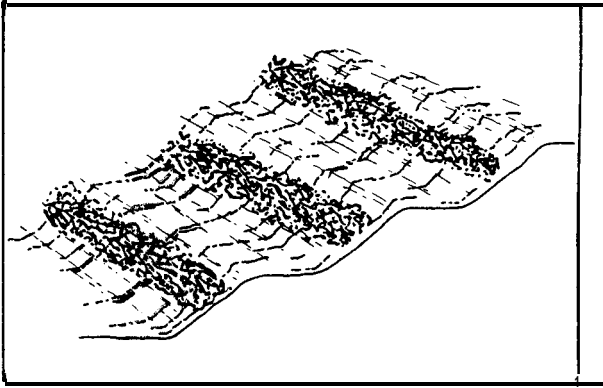

- . slopes no steeper than 21
- . rounded slopes
- high slopes should be stepped
- use waste material and cut fill to recontour

### TOPSOIL AND OVERBURDEN REPLACEMENT

**REPLACE OVERBURDEN EVENLY IN PIT.  
REPLACE TOPSOIL OVER THE  
OVERBURDEN.**

All the overburden that was removed and stockpiled when the pit was opened up must be spread evenly over the pit floor and smoothed over the recontoured side walls. If the pit was designed properly, there should have been a space left between the overburden stockpile and the surrounding forest so that equipment can easily get behind the overburden to push it down into the pit. It is not acceptable to leave the overburden in piles in the pit.

The saved topsoil which was set aside when the pit was opened, (unless there was none) must now be spread over the overburden. The topsoil contains seeds and organic material that will help regrowth of vegetation. Without any topsoil, revegetation is a much more lengthy process.



- x poor practice
- x impossible to respread overburden when mixed with logs, slash and debris
- spread overburden evenly on pit floor and slopes
- spread topsoil over the overburden
- topsoil speeds up revegetation

### REVEGETATION

The question of how, when and where to revegetate is hard to answer when you consider the whole of the NWT and Yukon because of the range of climatic, soil and growing conditions. The wide range of conditions possible at any given site makes it impossible to make generalizations about acceptable methods of revegetation.



- . plants grow very slowly in the far north

Once the pit has been recontoured and any overburden and topsoil have been replaced, the operator can decide to do one of three things based on the final land use, and on such limiting factors as climate, the type of surface material and its moisture holding capabilities:

1. allow natural revegetation with no assistance
2. allow natural revegetation with some assistance
3. completely assist revegetation

1. The decision to allow the site to naturally revegetate could occur in two widely different instances. One, in the High Arctic, where it would be hard to justify assisted vegetation in an area that is naturally barren; two, in forested areas and in the Mackenzie delta region where natural revegetation is rapid because of an available seed source. Here, any assisted revegetation would not significantly help speed up the process.



• natural revegetation from surrounding forest

2. In many areas, re-invasion of native species to the disturbed area may be speeded up by introducing some seed and fertilizer. It is strongly advised that in these instances, the introduced seed should be composed of native species that are found in the area. Native species may take longer to cover the area than non-native, quick growing plants, but it is more ecologically sound in the long run to choose native plants.



• native species

3. Completely assisted revegetation should only be considered in areas that are highly susceptible to erosion; the establishment of vegetation reduces this risk. One place that assisted revegetation techniques are commonly used is along highways on cut, fill and borrow slopes. In these cases, it is often preferable to introduce non-native grasses so that vistas, viewpoints and road signs are not blocked by taller growing, native woody shrubs and trees.

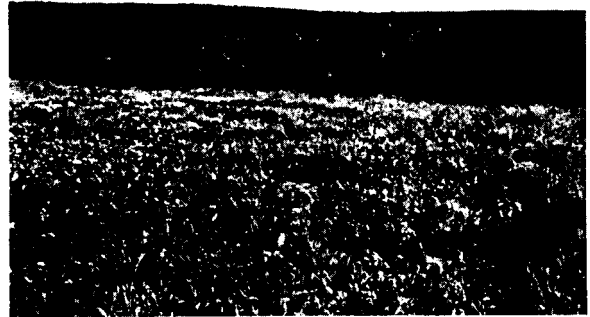

• assisted non-native vegetation

In cases where the pit is designated for future use, the revegetation methods are dictated by the use. In areas where there is nothing planned, the best guide is to undertake revegetation that encourages a return to conditions that you would generally expect to occur in the area.

### MONITORING AND MAINTENANCE

Responsibility for the pit does not necessarily end when the pit is restored. The Inspector may check on the site in sensitive areas after restoration to see if there are any problems. If any problems do arise due to poor restoration techniques, the operator can be asked to return to the site to ease the problem. Once clearance has been given by the Inspector, the operator's responsibility ends. In some cases (permafrost, sensitive areas) the Inspector may wait for up to a year before giving clearance to the site.

# Part 7 Permafrost

## WHAT IS IT?

Permafrost is ground that is frozen for at least one year. Most problems related to permafrost are associated with ice rich soils. The ice is found either mixed with soil or in ice lenses of many shapes and sizes. Permafrost can be only a few centimetres thick to several hundred metres thick depending on local conditions.

## WHERE IS IT?

Permafrost is found all over the North. 'Continuous' permafrost is generally found further north and has a solid thick layer of frozen ground. 'Discontinuous' permafrost is found further south; it is thinner, broken by thawed areas, and is found deeper in the ground.

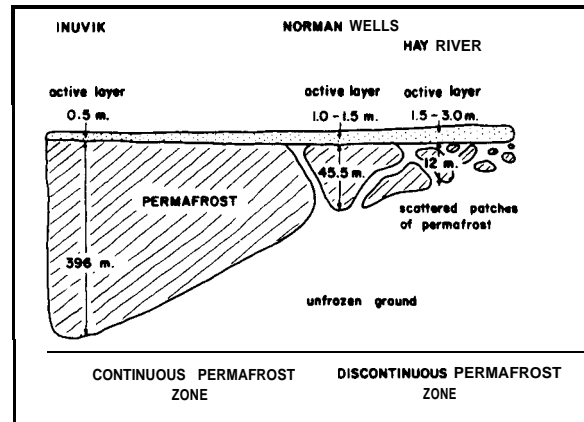

- continuous and discontinuous permafrost
- active layer

The active layer is the soil above the permafrost that freezes and thaws with the season. This layer is thicker in southern areas than in the far north. The organic layer and active layer act as insulation that keeps the underlying permafrost frozen each summer,

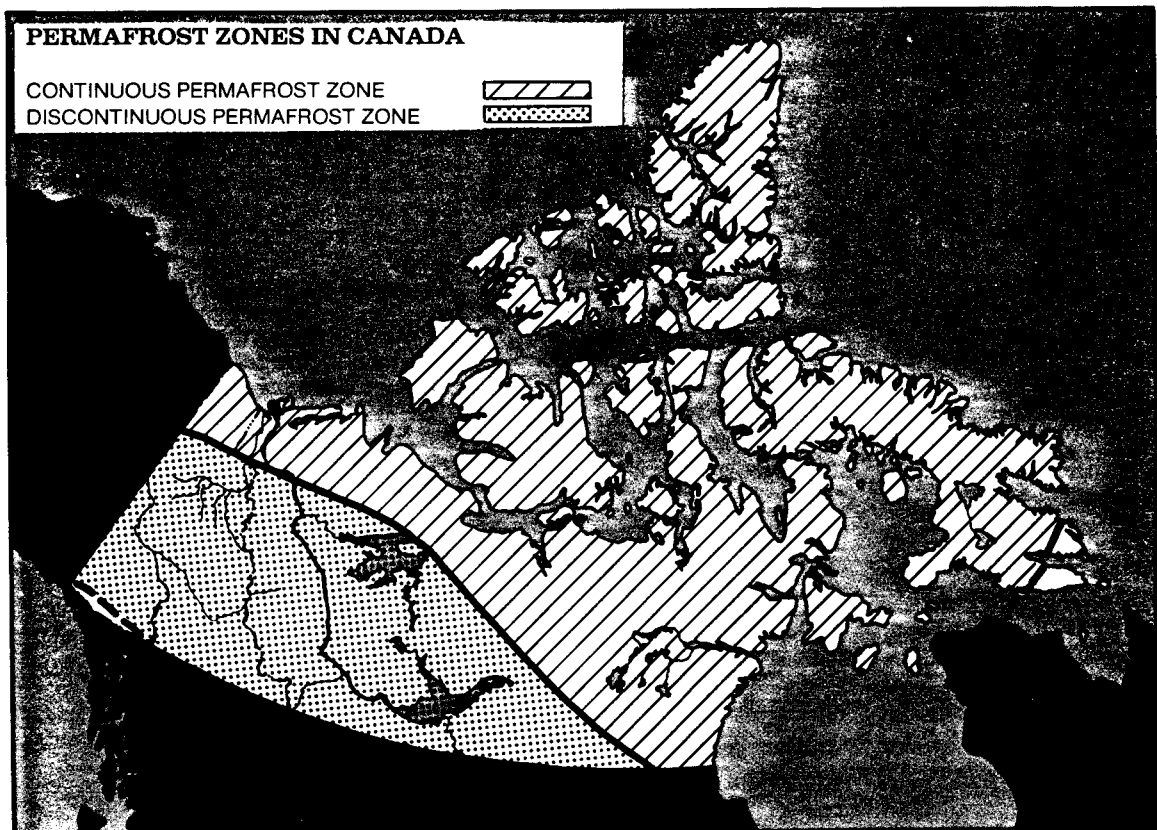





• ground ice



• typical ice lens

### PERMAFROST INDICATORS

Permafrost can be expected throughout the N.W.T. and Yukon. In the area of discontinuous permafrost however, it is hard to know exactly where it will show up. Usually, well-drained moss or peat bogs with only a few stunted trees have permafrost beneath them, Wet bogs or well-drained forests usually do not have permafrost. If the trees in a bog are falling over (a 'drunken forest') permafrost is likely to be found below.

- permafrost under moss and peat bogs usually with stunted trees
- not under wet areas
- not under high, well-drained forest

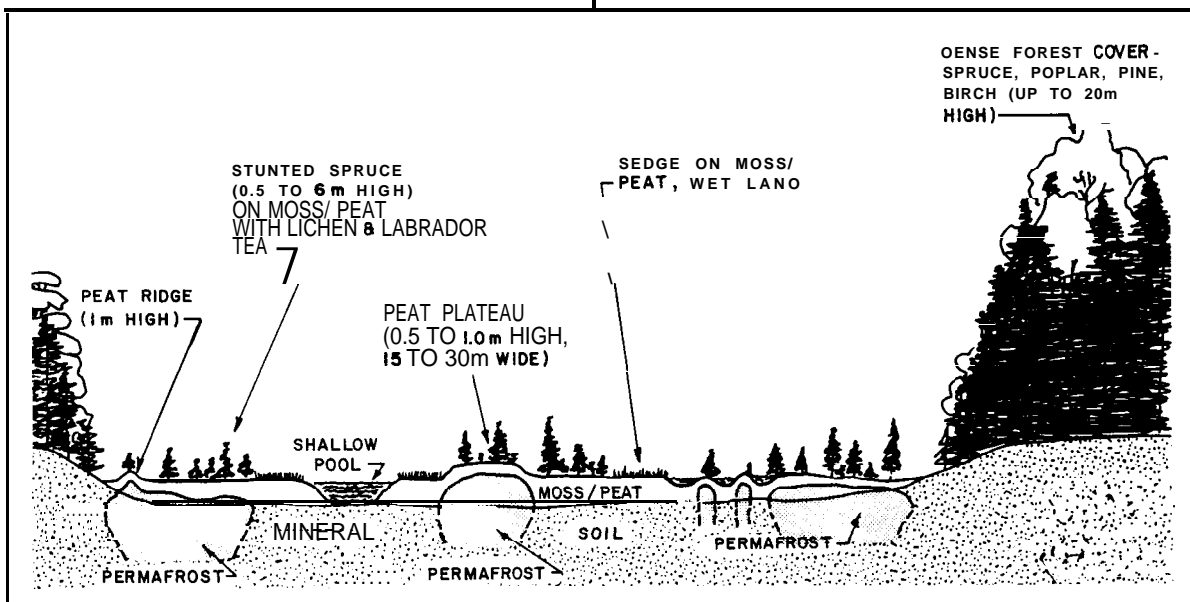

## PROBLEMS

### AVOID ICE RICH AREAS

The presence of permafrost, or frozen ground is not necessarily a problem; it is the amount of moisture within the frozen ground that causes all the trouble. A number of irreversible problems can occur due to improper operating techniques such as:

- thermokarst
- rutting
- flooding
- slumping

### Thermokarst

#### PRESERVE THE INSULATING LAYER

When a permafrost area is disturbed by stripping or by moving heavy equipment over the land surface, the upper insulating layer is destroyed and the underlying permafrost is exposed and starts melting. The ground then falls in, exposing more frozen area to thaw. The result is a large cave-in or hole which gets larger and deeper after each season of thawing.



. sink holes caused by thermokarst



### Rutting

#### AVOID USING THE SAME TRACKS REPEATEDLY FOR TRAVEL OVER PERMAFROST

Repeated use of one set of tracks across permafrost destroys the protective vegetation and removes the insulation that keeps the permafrost frozen through the summer. The deep, muddy tracks or ruts that result can eventually lead to thermokarst erosion and slope slumping.



x extensive rutting

At all times, the ground conditions must be solid enough to support whatever vehicles are being used. Make sure that you complete all operations before spring break-up so that you can move out equipment on a firm winter road. This will reduce the likelihood of rutting.

### Flooding and Drainage Control

#### ALLOW FOR DRAINAGE AWAY FROM THE PIT AS PERMAFROST THAWS

As permafrost melts, water drains out of the material and collects on the pit floor, making access and extraction very difficult.

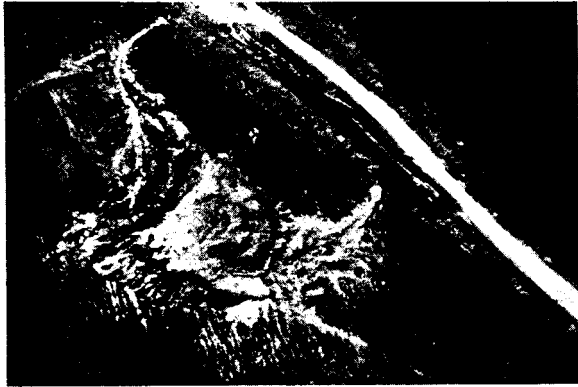

x flow from overburden into surrounding vegetation



x melt-out in permafrost

Overburden that has been piled along the edge of a pit may contain large amounts of water that will seep into the ground and flow down the pit walls. This water must be directed away from the site by pumping it out or by using drainage ditches (see Operations). If massive amounts of melt water are expected from large quantities of overburden, the operator is advised to remove the overburden to a new site with good drainage (see Design).

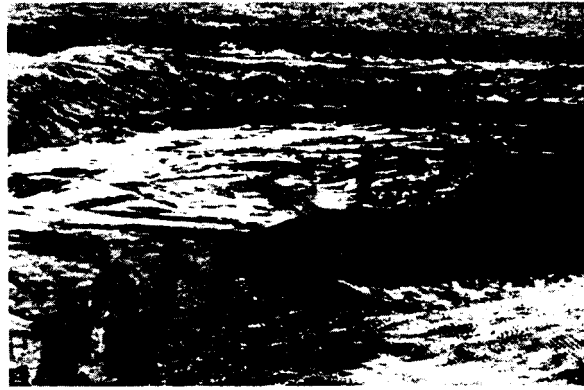

• wet permafrost pit



• drainage using a pump



• removal of overburden to a natural depression  
• overburden spread and contoured to low profile  
x do not smother well vegetated ground

If you have planned to restore the pit by letting it fill with water, contour the walls and protect them from erosion after all granular material has been removed; this may even look more natural than a large, dry unvegetated pit, since lakes are a common feature in the north.



• pit that has been allowed to fill with water

### slumping

**TRY TO AVOID CUTTING A SLOPE THROUGH GROUND ICE.**

**INSULATE ANY EXPOSED GROUND ICE.**

If there is water seepage or poor drainage on a steep slope, it can cause the whole slope to become unstable and slip downwards. This is a serious problem known as slumping.

In permafrost areas, slumping can be caused by two different factors:

- 1 ) isolated ground ice features, such as ice lenses, ice wedges
- 2) areas with high moisture content in the ground

**1) Ground Ice Features** In any excavation done in permafrost, danger arises when ground ice (an ice lens or wedge) is exposed along a pit wall. Rapid melting of the ice causes excess water to flow down the slopes, which, together with the extra weight of overburden and equipment working around the pit edge, can cause the whole slope to slump into the pit area.

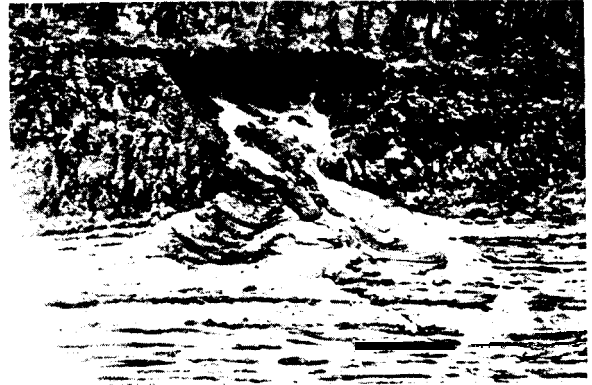

- ice melt out
- unstable slope
- mud slide

Try to prevent melt out by cutting the slope by the ice lens vertically; at the same time keep the surface mat of vegetation in place. When this mat droops over the open side, it will give shade and insulate the ice. Make sure you hand cut and remove the trees on the upper edge so that they do not tear the mat away.

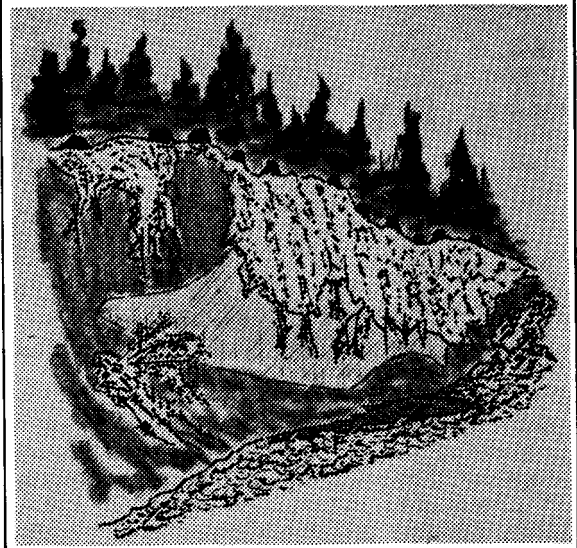

- cut slopes vertically
- keep surface vegetation mat in place
- remove trees on top by hand clearing
- allow overhang

**2) High Moisture Content Ground** It is stressed that ground with high moisture content should be avoided at all costs because of the operating problems that can occur. Special operating procedures for pits in high moisture content ground are explained in the following section,

## SEQUENCE OF OPERATIONS

Operations in permafrost environments must be planned well in advance because only a few centimeters of ground thaw each summer making extraction of material a slow process, generally extending over a number of years. The longer a cleared piece of ground is left, the greater the thaw depth.

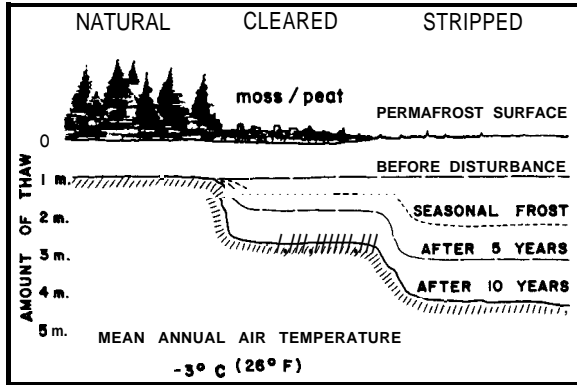

- trees and vegetation protect permafrost
- depth of thaw increases when area cleared of vegetation
- depth of thaw increases over the years

The previous section described some of the problems that can occur in permafrost due to incorrect planning and operating procedures. Some of these problems need never happen if some basic operating procedures are considered.

The following methods of pit excavation in permafrost stress the need for correct scheduling for different activities and the importance of slope insulation to protect the permafrost.

A pit can be operated in three different ways depending on the type of access available (winter or all-weather roads),

1. **Winter road only** - The pit is stripped of organics and overburden (if necessary) in winter. The underlying granular material is left in place over summer where it thaws and dries out. The following winter, the thawed, dry material can be excavated and hauled away.

OR 2. **Winter road only** - The pit is stripped of organics and overburden in winter. The following summer the thawed granular material is bulldozed into large rounded stockpiles. The stockpiled material then dries out over the remaining summer and can then be hauled away the following winter.

AND 3 **All weather access** - where a pit can be operated on a year-round basis a number of precautions must be taken so that the pit does not become flooded due to melting permafrost and slumping slopes. The following diagrams show a typical sequence of how a pit may be operated on a year-round basis.

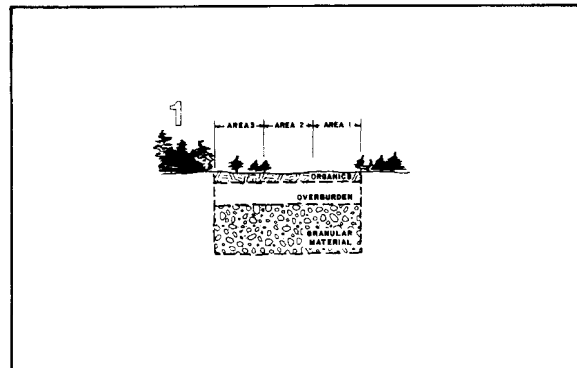

- divide pit into yearly working areas
- clear area
- retain slash for insulation

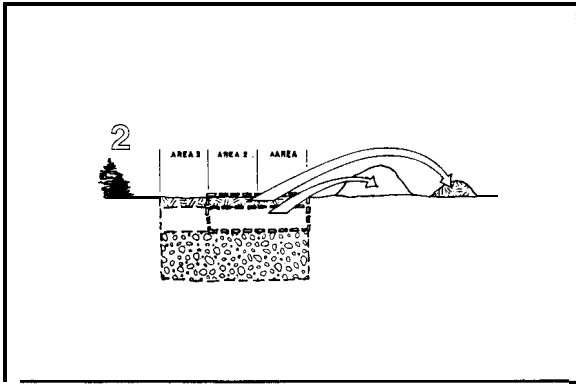

**Winter**

- . remove organic layer from areas 1 and 2 and stockpile separately
- . remove overburden from areas 1 and 2 and stockpile separately
- . allow for drainage away from pit

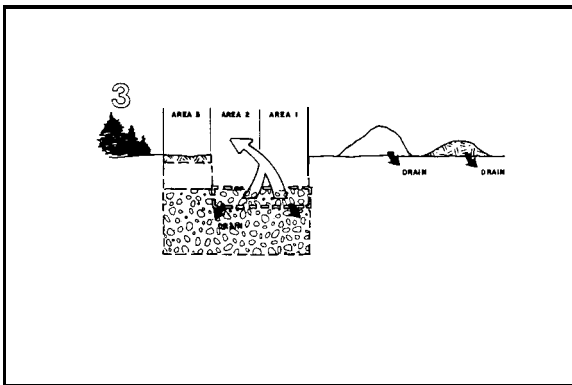

**Summer**

- . let upper layer of material thaw and dry out

**Late Fall**

- excavate and haul dry material from areas 1 and 2

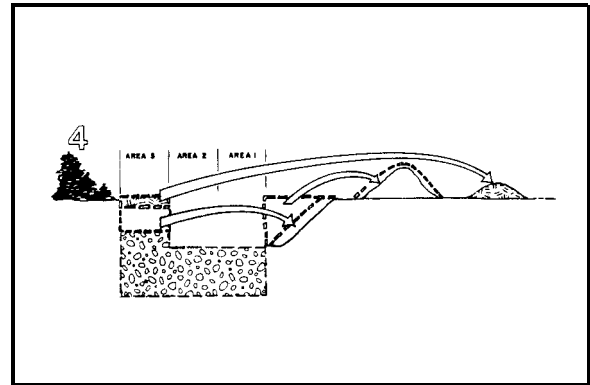

**Winter**

- remove organic layer from area 3 and stockpile with rest of organics
- cut wall of pit in area 1 to a slope
- stockpile cut waste with overburden or stockpile if usable as granular material
- remove overburden from 3 and place on slope of area 1 to insulate

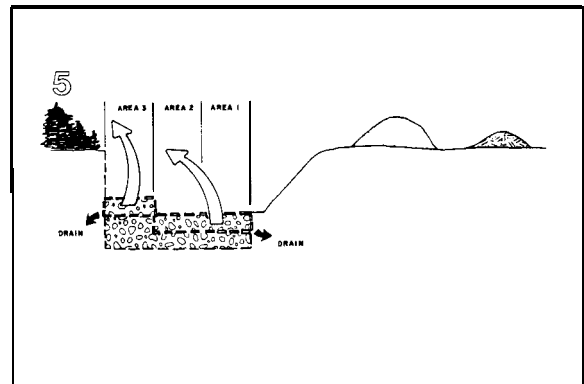

**Summer**

- . let upper layers of material thaw and dry out over summer

**Fall**

- . excavate and haul out dry material from areas 1, 2 and 3

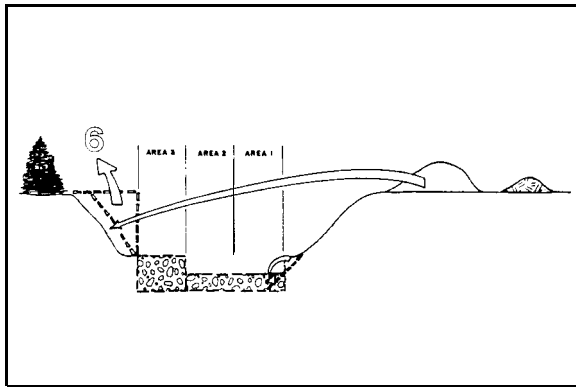

#### Winter

- cut back and slope pit wall in area 3
- slope wall of area 1
- use dry overburden to slope wall of area 1
- stockpile cutwaste, or if it is usable material, remove it and stockpile
- use dry overburden to insulate wall in area 3

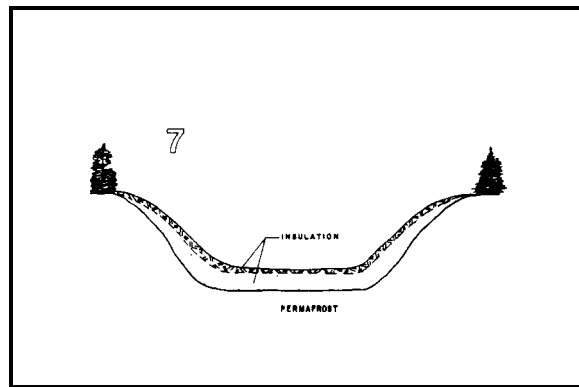

Continue excavation of pit until all the granular material has been removed. Remember to slope the side walls and insulate with dried out overburden. Use the remaining overburden to insulate the floor of the pit to prevent further melting of the permafrost. If any organic material was saved, it should be placed over the overburden to encourage revegetation.

The final pit area should look like this:

The importance of following the preceding guidelines can be seen when you look at the following illustrations.



- x poor planning
- x pit opened in summer
- x very wet working conditions
- x too much land disturbed

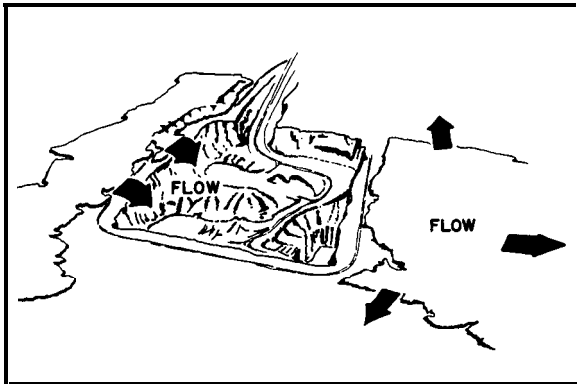

- x overburden stockpiled all over the place
- x overburden stockpiled too close to pit edge
- x uncontrolled melting



- x slumping pit wall
- x no insulation
- x very wet working conditions

#### Reclamation

- . cutaway the eroded leading edge and contour to 2:1 slope
- cover exposed edge with dry material and compact to prevent further slumping and melting



## PROCESSING

### STOCKPILE AND THAW WET OR FROZEN MATERIAL BEFORE PROCESSING

If granular material is removed from a pit during the winter, stockpile it on a well-drained area and allow it to thaw. Crushing of frozen or wet sticky material is not advised since small particles become stuck together into large clumps which will not pass through the screen of the crusher.

Using a belt conveyor to stockpile material is a good idea because the stockpiled material does not become compacted and it also has a chance to dry out.

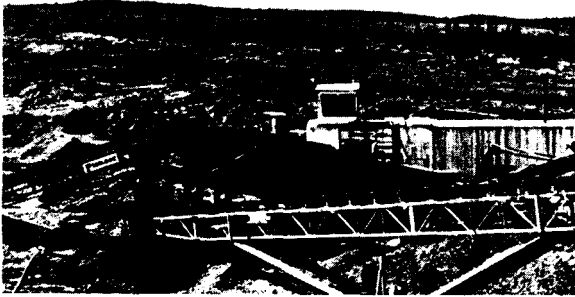

• typical permafrost operation

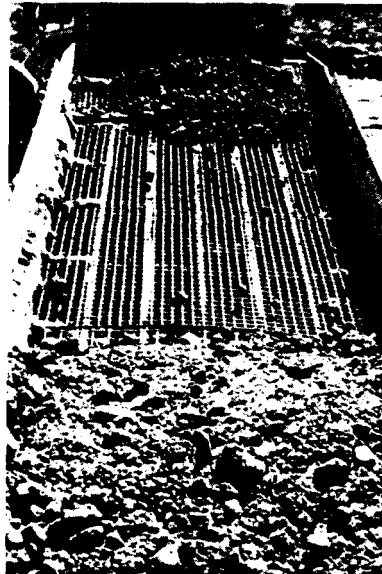

• clumping of material on screens

# Part 8 Quarries

The term 'pit' is used when granular materials are extracted. The term 'quarry' is used where consolidated rock is removed. This section on quarries presents some guidelines that apply specially to quarries, however, many of the guidelines contained in the planning, design, operation and restoration of pits apply just as much to a quarry, so these sections must be read as well.

## PLANNING

The first step in planning is to decide what kind of material you want and what you want it for. Two of the main types of material that can be obtained from a quarry are:

- . crushed rock
- rip rap/ armour stone

**Crushed rock is produced by passing blasted bedrock through a mechanical crusher to produce angular fragments which are commonly used for road surfacing and in community development projects.**



• bedrock crushing

**Rip rap is produced by special quarrying techniques that result in large-sized stone which is used to protect shorelines, bridges and culverts from wave and water action.**



• rip rap used for bank protection



• rock outcrops - potential source of material

For both these types of material, the operator needs to find a deposit with special properties and a rock type that is of good enough quality for the uses demanded of it.

| <b>Recommended Properties for Crushed Rock</b>   | <b>Recommended Properties for Rip Rap/<br/>Armour Stone</b>  |
|--|--|
| <p>must resist breakdown</p> <p>must resist abrasion</p> <p>min. hardness of 3</p> <p>min. effort required for crushing</p> <p>min. of fines</p> <p>should crush into equally sized fragments</p> <p>must be free of dirt</p>  | <ul style="list-style-type: none"> <li>- must remain in large fragments</li> <li>- must resist breakdown to small fragments</li> <li>- must resist abrasion</li> <li>- rock must be free of shale seams</li> <li>- must be free from planes of weakness</li> <br/> <li>- equally sized pieces</li> </ul>                                 |
| <b>Recommended Properties For Crushed<br/>Rock Deposits</b>  | <b>Recommended Properties for Rip Rap/<br/>Armour Stone Deposits</b>   |
| <ul style="list-style-type: none"> <li>- continuity for min. sorting</li> <li>- must be able to drill blast holes</li> <li>- carbonates easier to drill than quartzites</li> <li>- should react equally to charge</li> <li>- should allow uniform breakage</li> <li>- air blasts undesirable</li> <li>- oversize blocks undesirable because they require secondary blasting</li> </ul> | <ul style="list-style-type: none"> <li>- wide spacing of fractures so that large pieces may be extracted</li> <li>- continuity for min. sorting</li> <li>- must be able to drill blast holes</li> <br/> <li>- blasting should cause deposit to part along seams</li> <li>- should yield quantity of large size pieces or rock</li> </ul> |



- close-up of dolomite
- note the thin contorted bedding



- intensely jointed limestone/dolomite
- weathering into small fragments along closely spaced joint planes

## Schedule

Spring is the most important season for wildlife. The operator of a quarry must be aware that the Inspector may prohibit all blasting during this season because loud noises can easily disturb nesting, egg incubation and raising of young. Therefore, if the quarry is located in a sensitive area for wildlife, the operator should not plan to start working until this critical time has passed.

Fall is also an important time for wildlife. Large groups of birds and animals congregate at this time in preparation for, or in the process of migration. All operations could be suspended if necessary.

If the quarry is located near a recreation area, the number of trips made by trucks hauling material, and the number of blasts maybe restricted by the Inspector during summer months.

## DESIGN

The design stage in quarry operations is as important as for pits. If the quarry is designed properly from the start then operating problems are reduced and the operator will find that he has a tidy and efficient operation.

### Location and Orientation

In areas where the quarry is located close to public view, some kind of visual screening must be given. This is done best by not quarrying sites that are either on a prominent cliff or on a hill facing a road. Protection may also be given by doglegging the access road to the quarry.

Just as important as locating the quarry away from public view, is to orient the working face of the quarry away from sensitive wildlife areas, picnic sites, recreation areas and settlements. The need for this is to direct the noise from blasting away from these areas.

- dogleg access
- orient pit away from sensitive areas
- x do not locate in prominent places

Correct orientation of a quarry with respect to the natural jointing of the rock can make a real difference to the ease of rock removal and to the height and shape of the quarry walls. Orientation varies, depending on whether you are removing crushed rock or rip rap/armour stone.

In crushed rock quarries, it is advantageous to orient the walls so that they parallel a major joint set. The rock will tend to break away along the joint planes, so following them will make shaping of the pit walls easier.

In deep quarries for armour stone, the walls should be designed so that they will be cut by major joint sets rather than lying parallel to them, as with crushed rock quarries. Orienting the walls this way also makes them more stable and therefore safer.

- orient walls parallel to joints for crushed rock
- orient walls across joints in deep armour stone quarries

### Overburden

It is best to find a quarry location that has a minimum amount of overburden so that the operator does not have to do much stripping of surface material. If any amount of overburden and surface vegetation is present, then it must be removed in the same way as in pits, and stockpiled in low mounds in well-drained locations.

### Size and Depth of Quarry

A deep quarry is preferable to a shallow one because a deep site reduces the amount of surface disturbance for the amount of material obtained. Deep quarries are especially good if you are extracting armour stone, because a greater depth allows you to get at un-weathered rock.

The depth of the quarry is controlled by the site geology and local drainage conditions. A flooded quarry is no good for operating in.

Shallow sites tend to extend over much larger areas, increasing the effect on the environment.

The quarry in the photograph below is only about 10 metres deep, but it could have been excavated to a depth of about 30 metres.

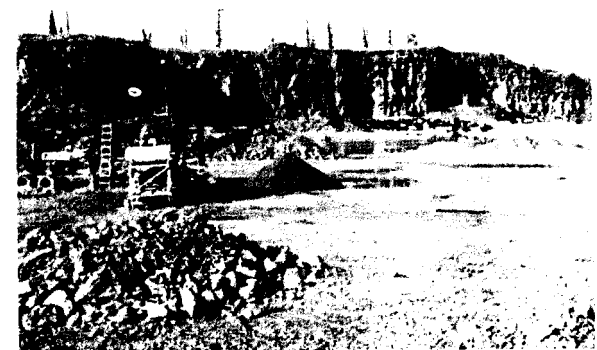

- better to have deeper quarry over smaller area
- x shallow quarry
- x extends over large area

## Benches and Slopes

Benches are necessary both as a working platform, and as a safety device to break the fall of rock and debris. Bench heights vary with the type of operation. Standard bench heights of units of 5 metres are recommended in crushed rock quarries where a number of operators may be working. They can therefore work two 5 metre faces or one 10 metre face.

In deeper armour stone quarries, the bench heights should really be determined by the form of the deposit and the jointing structure. Bench heights therefore are flexible,

- benches of units of 5 metres in crushed rock quarries
- flexible bench heights in armour stone quarries

The width of benches at any site should provide enough safe working space. The recommended width varies from 30-60 metres, but the width of the bench should never be less than the height of the wall above it.

Such wide benches with relatively shallow faces give the quarry a generally low overall slope angle, which should not exceed 45°.

- . bench width should provide working space
- . bench should be from 30-60 m wide
- overall slope angle should not exceed 45°

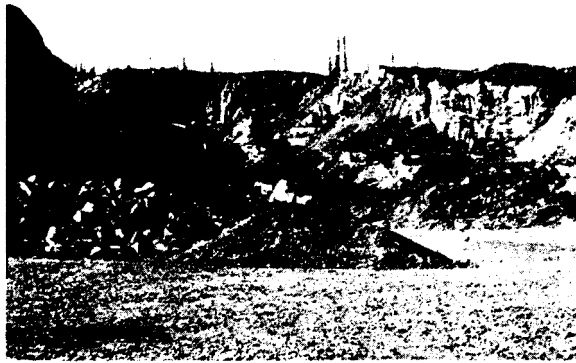

- vertical pit walls
- walls are formed on joint faces
- x bench not wide enough for working
- x inadequate access ramp

## Drainage

Before any excavation starts, the operator should design any runoff control measures that might be required to redirect surface runoff away from the quarry walls. Remember that when flow is redirected it must not result in erosion of a slope or siltation of a stream.

As with pits, accumulation of water in the working area is not good. However, in the case of quarries, the floor of the working area may be designed at a slight angle (at least 10) so that any water will flow away from the working area.

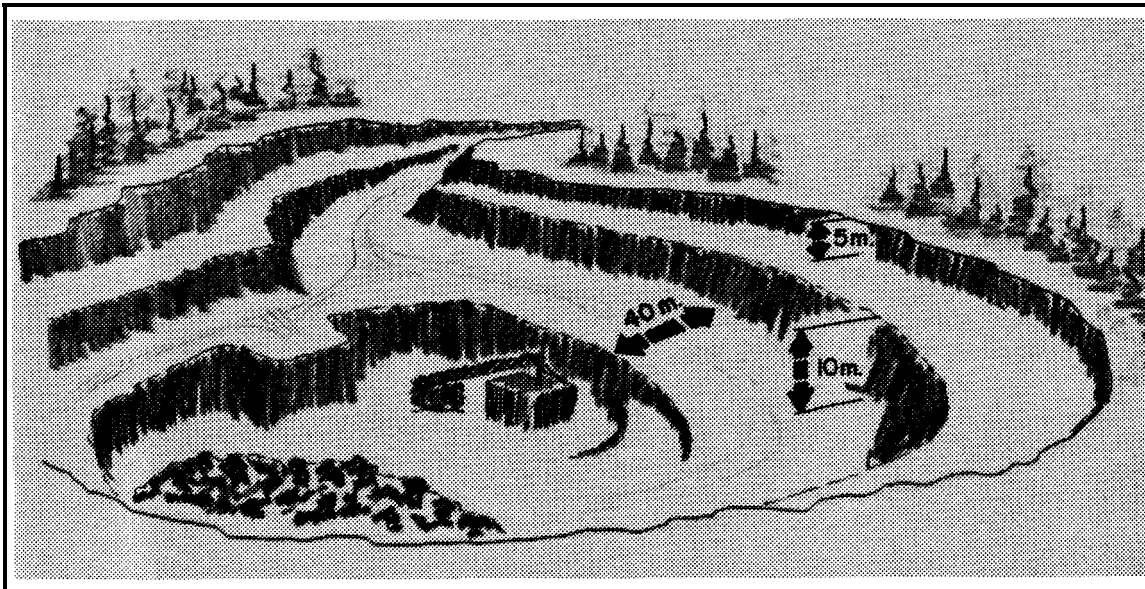



• dry, clean entrance and work area

### **Stockpile**

Stockpile locations in the quarry must be located so that they are easily accessible from the working face, the crusher and the access road. The area around the stockpile is a heavily used area and therefore you must make sure that the stockpile is on dry and durable ground. In a quarry where different sizes of material are being extracted and processed, the stockpile should not be placed so that the different materials mix together.

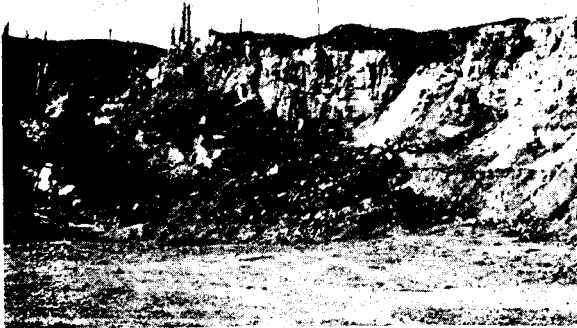

• stockpiled limestone at pit entrance  
• large blocks suggest pmr blasting



• heavy use around stockpile

### **OPERATIONS**

Material is extracted from a quarry by blasting. Blasting can be very dangerous if it is not done correctly with the proper safeguards. Therefore every possible precaution must be taken when handling, storing and transporting explosives. Only experienced people are allowed to handle explosives. For full details on safety procedures, you must read the Northwest Territories Mining Safety Ordinance and the Yukon Blasting Ordinance.

### Sequence of Extraction

The rock face must be worked inwards and downwards to create benches and faces to the given specifications,

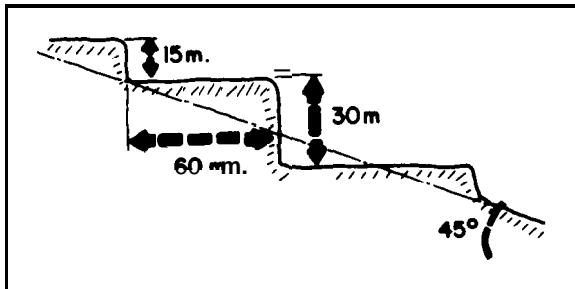
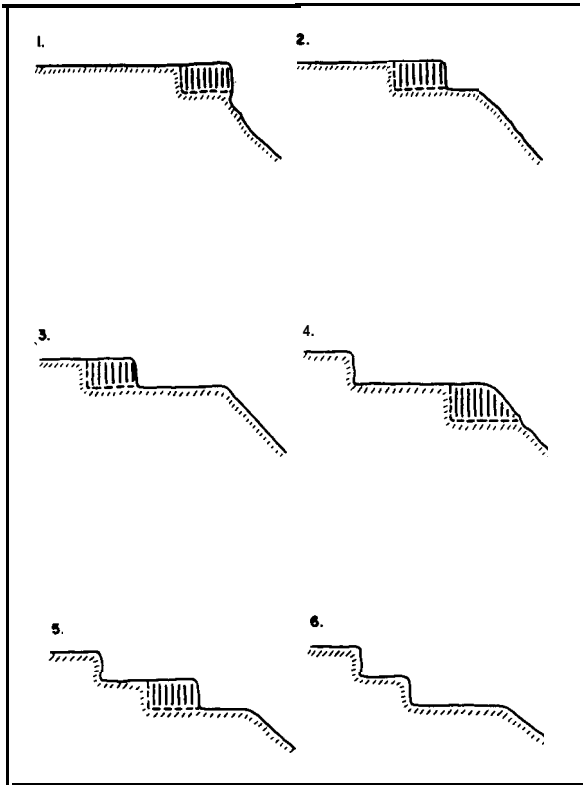

The final angle of the overall slope must not exceed 45°

### RESTORATION

There are not many physical steps that can be taken to restore a quarry, but two things can and must be done

- clean-up
- drainage control

The entire quarry area must be cleaned up of any debris, garbage, wire and unused explosives on completion of the quarry operation.

Drainage ditches leading out from the quarry must be left open and unblocked.

If the quarry is very deep and extends below the water table level, natural flooding is an acceptable measure of restoration, **after the quarry has been cleaned up.**

# Glossary

|                                     |   |
|-------------------------------------|---|
| <b>Active layer:</b>                | the layer of ground in permafrost which thaws each summer and refreezes each fall.  |
| <b>Angle of repose</b>              | the maximum angle that the inclined surface of a pile of loosely divided material can make with the horizontal.   |
| Armour <b>stone:</b>                | <b>see</b> Rip rap  |
| <b>Aspect:</b>                      | the direction toward which a slope faces.   |
| Bench                               | a step of level earth or rock that is cut away to break a steady slope.   |
| <b>Berm:</b>                        | a manually formed hill, generally elongated and with rounded edges.   |
| <b>Bog:</b>                         | peat-covered areas or peat-filled depressions with a high water table, and a surface layer of mosses.   |
| <b>Buffer strip</b>                 | a strip of vegetated land left undisturbed adjacent to a disturbed area that hides it from view.  |
| Channel diversion                   | a ditch constructed to intercept surface runoff, changing the natural course of the flow.   |
| <b>Chemical weathering:</b>         | the chemical decomposition of earth and rocky materials.  |
| <b>Commissioner's Land:</b>         | a parcel of land surrounding a community set aside for its use and protection, controlled by the Territorial government.  |
| <b>Compaction</b>                   | the closing of the pore spaces among particles of soil and rock; to press together.   |
| <b>Concrete aggregate:</b>          | granular material which meets the specifications for concrete. Such requirements are that it should consist of clean, hard, strong, and durable particles free of chemicals, coatings of clay or other fine materials that may affect hydration and bond of the cement paste. |
| <b>Consolidation</b>                | process by which a saturated soil becomes firm and compressed, squeezing out some of the water.   |
| <b>Continuous permafrost zone</b>   | area underlain by a solid layer of unbroken, permanently frozen subsoil.  |
| <b>Contouring:</b>                  | the act of physically moving or removing land in curves according to an imaginary line connecting points of equal elevation. It follows the natural slopes and edges of land forms.   |
| <b>corduroy road:</b>               | a road surface constructed by laying down even lengths of large logs side by side perpendicular to the line of travel.  |
| <b>Crevasse filling:</b>            | a relatively straight ridge of stratified sand and gravel, till or other sediments. Crevasse fillings may resemble eskers but are not generally as winding or branching.  |
| <b>Cross ditch</b>                  | a small ditch constructed across a road to allow water to travel to the lower side without eroding or ponding. It also provides a barrier to vehicles.  |
| <b>Crushable granular material:</b> | unprocessed gravel containing a minimum of 35% coarse aggregate larger than #4 sieve.   |
| <b>Crushed rock:</b>                | is produced by passing blasted bedrock through a mechanical crusher to produce angular fragments.   |
| <b>Debris:</b>                      | any unwanted material such as dirt, surface stripping, slash, stumps, garbage, etc.   |
| <b>DIAND:</b>                       | the Department of Indian Affairs and Northern Development   |



|                                      |  |
|--------------------------------------|--|
| <b>Discontinuous permafrost zone</b> | an area underlain by a relatively thin layer of permanently frozen subsoil found deep in the ground and broken by thawed areas.  |
| <b>Diversion ditch:</b>              | <b>see</b> Channel diversion.  |
| <b>Dogleg</b>                        | a 'jog' or sharp curve in a road right-of-way which conceals a clearing beyond the curve from view.  |
| <b>Drunken forest:</b>               | a group of trees leaning in random directions usually associated with a frozen subsurface.   |
| <b>Erosion</b>                       | the process of detachment and movement of soil or rock fragments by running water, wind, ice or gravity.   |
| <b>Esker:</b>                        | a long, narrow, winding ridge composed of stratified accumulations of sand and gravel, perhaps with some silt, cobbles, boulders and till.   |
| Extraction                           | the taking of material from its undisturbed location,  |
| <b>Equipment</b>                     |  |
| <b>Backhoe:</b>                      | an excavator fitted with a hinged arm to which a bucket is rigidly attached that is drawn toward the machine in operation.   |
| <b>Bulldozer:</b>                    | a wheeled or crawler tractor equipped with a reinforced, curved steel plate mounted in front, perpendicular to the ground, for pushing excavated material.                                   |
| <b>Chipper:</b>                      | a machine used for ingesting large pieces of wood, such as twigs, branches, small trunks and chopping them into small wood chips.  |
| <b>Crusher:</b>                      | a machine used for crushing rock and other bulk materials.   |
| Primary <b>crusher/ breaker:</b>     | a machine that takes over the work of size reduction from blasting operations, crushing rock to a maximum size of about 5 centimetres in diameter; may be a gyratory crusher or jaw crusher. |
| <b>Secondary crusher:</b>            | crushing and pulverizing machines used after the primary breaker to further reduce the particle size of rock or gravel.  |
| <b>Belt conveyor:</b>                | a cycling belt used to transport large volumes of loose material along a designated route from a large source (e.g. crusher to stockpile).   |
| <b>Loader:</b>                       | a machine such as a mechanical shovel used for loading bulk materials.   |
| Fines:                               | very fine particles such as clay and silt which can pass through a standard screen   |
| <b>Fractured face:</b>               | a crushed particle which has at least one freshly broken and well defined face.  |
| <b>Granular material</b>             | materials which are commonly known as sands and gravels. Technically, granular materials include natural sizing from silts to sand and gravel to cobbles.                                    |
| Grizzly                              | a coarse screen or series of parallel rods or bars used for rough sizing of gravel.  |
| <b>Ground ice</b>                    | any ice feature associated with permafrost such as an ice lens or ice wedge.   |
| <b>Grubbing:</b>                     | the clearing of stumps and roots.  |
| <b>Guideline</b>                     | a recommended practice   |
| <b>Hand cutting:</b>                 | clearing of timber and brush utilizing hand tools, thereby leaving the root systems intact to minimize surface disturbance.  |
| <b>Hardness</b>                      | resistance to scratching or abrasion. The hardness of a mineral is compared with a standard, e.g. 1 = Talc, 3 = Calcite, 7 = Quartz, 10 = Diamond.   |

|                             |   |
|-----------------------------|---|
| <b>High water mark</b>      | the mark where the water level along streams, rivers, or beaches is at its greatest elevation.  |
| <b>Ice bridge</b>           | bridge constructed in winter to cross streams. It maybe built up with snow or limbed logs, but never with slash or dirt.  |
| <b>Ice lens</b>             | a mostly horizontal lens-shaped body of ice of any dimension. The lenses may range in thickness from a hairline to as much as about 10 metres.  |
| <b>Ice wedge</b>            | a massive, generally wedge-shaped body with its apex pointing downward, composed of layered, vertically oriented, commonly white ice; from less than 10 cm to 3 m or more wide at the top, tapering to a feather edge at the apex at a depth of 1 to 10 m or more. Some ice wedges may extend downward as far as 25 metres. |
| <b>Inspector:</b>           | any person designated for the area in which the operation will be located by the Minister of Indian Affairs and Northern Development to ensure that the terms and conditions of the licence or permit or the regulations are being complied with.   |
| <b>Kame</b>                 | a short, steep-sided ridge, hill or mound of glacially derived sands and gravels.   |
| <b>Limestone</b>            | a sedimentary rock composed mainly of calcium carbonate (CaCO <sub>3</sub> )  |
| <b>Material:</b>            | <b>see</b> Granular material.   |
| <b>Merchantable timber:</b> | any trees which are of adequate size to be salvaged for use.  |
| <b>Mica:</b>                | a soft, friable mineral which is easily broken down into fine particles   |
| <b>Monument:</b>            | a survey post used to locate a fixed point.   |
| <b>Opening up</b>           | the preparation of a pit or quarry site from an undisturbed condition for the working and extraction of material and includes surface clearing and overburden removal and placement.  |
| <b>Operator:</b>            | person granted a permit or licence to conduct a pit or quarry operation.  |
| <b>Organic layer:</b>       | that portion of the soil which contains decomposed or partially decomposed vegetation (peat, humus).  |
| <b>Outcrop</b>              | exposed stratum or body of rock at the surface of the earth.  |
| <b>Overburden</b>           | material of any nature, that overlies a deposit of useful material at a pit or quarry   |
| <b>Peat:</b>                | unconsolidated, compressible material consisting of partially decomposed remains of plants  |
| <b>Permafrost</b>           | the thermal condition in soil or rock where temperatures below 0° C persist over at least two consecutive winters and the intervening summer.   |
| <b>Permeability</b>         | the capacity of soil or rock mass for transmitting water.   |
| <b>Permit:</b>              | a form by which the Minister authorizes one to operate a pit for a term of not more than one year.  |
| <b>Physical weathering</b>  | physical disintegration of earthy and rocky materials on exposure to atmospheric agents such as wind and water.   |
| <b>Pingo</b>                | a cone shaped mound or hill, with a circular or oval base which has a core of massive ground ice covered with soil and vegetation and which exists for at least two winters.  |
| <b>Pit:</b>                 | means a site where granular material, not including consolidated rock, is being or has been taken.  |

|  |   |
|--|---|
| <b>Pit or quarry operation:</b>        | means activities at a pit or quarry associated with the opening up of the site or any portion thereof, or the extraction, processing, stockpiling or removal of materials from the site, or the restoration of the site, and includes any works, machinery, plant, buildings and premises belonging to or used in connection with the pit or quarry.    |
| <b>Pollution</b>                       | destruction or impairment of the purity of the environment.   |
| <b>Processing:</b>                     | means the screening, blasting, crushing, draining or any other preparation of excavated material prior to stockpiling or removal.   |
| <b>Public pit or quarry operations</b> | means a pit or quarry operated by a Department or agency of the Government of Canada, by the Commissioner of the Northwest Territories or the Yukon Territory, by a municipal or settlement council or by a private licensee or permittee, the operation of which is authorized by the Minister as a source of materials for use by the general public. |
| <b>Pulaski:</b>                        | hand tool used for cutting brush and digging a fire guard or trench   |
| <b>Quarry:</b>                         | an open excavation or surface working for the extraction of stone.  |
| <b>Quartzite:</b>                      | a strong, hard granulose metamorphic rock consisting mainly of quartz.  |
| <b>Ramp:</b>                           | a uniformly sloping surface inclined from an embankment to river level which serves as access to an ice bridge.   |
| <b>Recontouring:</b>                   | grading disturbed land to an acceptable landform  |
| <b>Recreation area:</b>                | potential and designated land areas which have been reserved or are used for recreational purposes.   |
| <b>Regulations</b>                     | means the Territorial Land Use Regulations and the Territorial Quarrying Regulations.   |
| <b>Restoration</b>                     | the rehabilitation of a pit or quarry so as to return it to a stable condition and make it look as natural as possible,   |
| <b>Revegetation:</b>                   | the provision of vegetative cover on a disturbed site.  |
| <b>Rip rap:</b>                        | means any sheet of material, usually irregular stones or boulders, used to cover the face of and shield earth fills, embankments and abutments from erosion by water.   |
| <b>Rutting:</b>                        | means a track made in the ground by the passage of vehicles   |
| <b>Sediment:</b>                       | solid material, both mineral and organic, that is in suspension, being transported or has been moved from the site of origin by air, water, gravity or ice,   |
| <b>Sedimentation</b>                   | the process of depositing a solid material (silt, mud, fill) into a liquid (stream, waterbody) where it is distributed or settles out,  |
| <b>Sensitive areas</b>                 | areas which are rated as high value for timber, recreation, watershed, wildlife, archaeological or historic sites, and unique land forms.<br><br>or - areas which would be adversely effected by disturbance such as waterbodies or beaches.  |
| <b>Sensitive wildlife area</b>         | habitat areas which are critical to a significant number of individuals of a species during at least part of the year, e.g. waterfowl staging and production areas, game bird dancing grounds, ungulate winter ranges.  |
| <b>Shale</b>                           | a laminated, fine-grained sedimentary rock containing clay  |
| <b>Slash:</b>                          | branches, bark, tops, cull logs, underbrush   |

|                           |   |
|---------------------------|---|
| <b>slope</b>              | an inclined surface at angle 2:1 two horizontal to one vertical<br>3:1 three horizontal to one vertical   |
| <b>slumping</b>           | a type of landslide characterized by the downward slipping of a mass of unconsolidated debris into a heap at the bottom of an incline.  |
| <b>Stream:</b>            | means any lake, river, pond, swamp, marsh, channel, gully, coulee or draw that continuously or intermittently contains water.   |
| <b>sump</b>               | means a manmade or natural pit, trench, hollow or cavity in the earth's surface used for the purpose of depositing waste material.  |
| <b>Terrace</b>            | sloping ground cut into a succession of benches for purposes of controlling surface runoff, minimizing soil erosion and assisting revegetation.   |
| <b>Territorial lands:</b> | means lands in the Northwest Territories or in the Yukon Territory that are vested in the Crown or of which the Government of Canada has the power to dispose.  |
| <b>Thermokarst:</b>       | the irregular topography resulting from the process of differential thaw settlement or caving of the ground because of the melting of ground ice.   |
| <b>Till:</b>              | Nonsorted, nonstratified sediment carried or deposited by a glacier (clay, sand, gravel, boulders).   |
| <b>Tundra:</b>            | a treeless, generally level to undulating, region of lichens, mosses, sedges, grasses, and some low shrubs, including dwarf willows and birches, which is characteristic of both the Arctic and higher alpine regions outside the Arctic. |

# Appendix A

## List of Contacts

### LIST OF DIAND OFFICES

#### NORTHWEST TERRITORIES

Regional Manager, Land Resources,  
DIAND  
P.O. Box 1500  
Yellowknife, N.W.T.  
XIA 2R3

District Superintendent  
DIAND  
P.O. Box 2550  
Yellowknife, N.W.T.  
XIA 2P8

District Manager  
DIAND  
P.O. 60X 658  
Fort Smith, N. WT.  
XOE OPO

District Manager  
DIAND  
P.O. Box 2100  
Inuvik, N.W.T.  
XOE OTO

District Manager  
DIAND  
P.O. Box 150  
Fort Simpson, N.W.T.  
XOE ONO

District Manager  
DIAND  
Rankin Inlet, N.W.T.  
XOC OGO

Assistant District Manager  
DIAND  
Baker Lake, N.W.T.  
XOC OAO

District Manager  
DIAND  
Frobisher Bay, N.W.T.  
XOA OHO

Resource Management Officer  
DIAND  
P.O. 60X 1420  
Hay River, N.W.T.  
XOE ORO

Resource Management Officer  
DIAND  
P.O. Box 126  
Norman Wells, N.W.T.  
XOE OVO

Resource Management Officer  
DIAND  
Fort Liard, N.W.T.  
XOG OAO

#### YUKON TERRITORY

Regional Manager, Land Resources.  
Attention: Land Use Section,  
DIAND  
200, Range Road  
Whitehorse, Yukon  
YIA 3V1

Resource Management Officer  
DIAND  
Watson Lake, Yukon  
YOA 1 CO

Resource Management Officer  
DIAND  
Teslin, Yukon  
YOA 160

Resource Management Officer  
DIAND  
Whitehorse, Yukon

Resource Management Officer  
DIAND  
Haines Junction, Yukon  
YOB 1 LO

Resource Management Officer  
DIAND  
Beaver Creek, Yukon  
YOB IAO

Resource Management Officer  
DIAND  
Carmacks, Yukon  
YOB 1 CO

Resource Management Officer  
DIAND  
Ross River, Yukon  
YOB 1S0

Resource Management Officer  
DIAND  
Mayo, Yukon  
YOB 1 MO

Resource Management Officer  
DIAND  
Dawson City, Yukon  
YOB IGO

# Appendix B

## Recommended References

### RECOMMENDED REFERENCES FOR AN OPERATOR

- Alberta Energy and Natural Resources. 1979. The Resource Handbook. Prepared by Alberta Forest Service
- Canadian Petroleum Association. 1977. Environmental Operating Guidelines for The Alberta Petroleum Industry. Prepared by James F. MacLaren Limited.
- Department of Indian Affairs and Northern Development, Canada. 1982. Administrative Guide.
- Department of Indian and Northern Affairs. 1978. Northwest Territories Mining Safety Ordinance and Mine Safety Rules.
- Department of Indian and Northern Affairs. 1977. Revegetation Information Applicable to Mining Site in Northern Canada. Environmental Studies, No.3. Prepared by E.B. Peterson and N.M. Peterson.
- Department of Indian and Northern Affairs. Winter Roads Manual. Environmental Studies No. 4.
- Department of Local Government. Site Development Handbook.
- Department of Public Works, Canada. 1979. Annual Report of The Environmental Co-ordinator, Shakwak Project. Prepared by R.B. Spencer, Environmental Co-ordinator, Shakwak Project.
- Environment Canada. 1976. Environmental Design for Northern Road Developments. EIA Reports EPS-8-EC-76-3. Prepared by Thurber Consultants Limited.
- Environment Canada. 1979. Environmental Code of Good Practice for Highways and Railways EPS I-EC-79-2. Prepared by Storgaard and Associates.
- Northern Affairs Program. 1982. Northern Natural Resources Development: Requirements, Procedures, and Legislation.

# Appendix C

## Conversion Table

### CONVERSION TABLE

#### Length

1 inch = 2.54 centimetres

1 foot = 0.3048 metres

1 yard = 0,915 metres

1 mile = 1.609 kilometres

1 millimetre = 0.039 inches

1 centimetre = 0.394 inches

1 metre = 3.28 feet

1 kilometre = 0.621 mile

#### Volume (dry)

1 cubic inch = 16,387 cubic centimetres

1 cubic foot = 0.028 cubic metres

1 cubic yard = 0,765 cubic metres

1 cubic centimetre = 0.061 cubic inches

1 cubic metre = 35.315 cubic feet

1 cubic metre = 1.308 cubic yards